



Commercial Split *Classic*[®] Series A/C Air Handler



RHCYA Series

Nominal Sizes: 7.5, 10 Small, 10 Large, 12.5, 15 & 20 Tons

[26.4, 35.2, 35.2, 44.0, 52.8 & 70.3 kW]

Cooling Capacities: 72.2k Btu/h to 240.0k Btu/h [21.2 kW to 70.3 kW]

Refrigerant Type: R-454B

Designed for use with matching RACY models



9001:2015



LISTED



TABLE OF CONTENTS

Unit Features and Benefits	3-4
Model Number Identification	5
General Data	6-11
Unit Dimensions.....	12
Electrical Data	13-17
Auxiliary Electric Heater Kit Characteristics and Application.....	18-21
A2L Refrigerant Installation Safety Data	22-24
Airflow Performance Data	25-36
Dimensional Data	37-38
Piping Recommendation	39-40
Guide Specifications	41-43
Limited Warranty	44



RHCYA STANDARD FEATURES INCLUDE:

- Designed for R-454B refrigerant
- Wired and run tested
- Convertible airflow – vertical up flow or horizontal sideflow
- Cooling operation up to 125°F ambient
- TXV refrigerant metering system
- Field-adjustable TXVs
- Solid-core liquid line filter drier
- Insulation encapsulated throughout entire unit
- Galvanized steel drain pan
- Standard Variable Frequency Drives (VFDs)
- Unit cabinet design shall be separable to facilitate mobilization during installation
- MERV 8 & MERV 13 filters are available as an accessory



Designing for Sustainability with Low GWP: For 2025, the Environmental Protection Agency (EPA) has set a global warming potential (GWP) limit of 700 for refrigerant used in heating and cooling systems. This new requirement will result in a 78%¹ lower GWP than previous-generation refrigerants - with only minimal changes to system installation. For us, this is another step toward our continued sustainability goal of reducing greenhouse gas emissions, while still delivering an exceptional level of energy efficient, dependable comfort.

¹When comparing the GWP of R-454B to R-410A refrigerant.

ACCESSORIES

ACCESSORY DESCRIPTION	MODEL NUMBER	SIZE USED ON	DIMENSIONS D x L x W (INCHES)
MERV 13 Filter	RXMF-M13A11625	090, 120	1X16X25
	RXMF-M13A12025	121,150,180,240	1X20X25
	RXMF-M13A21625	090, 120	2X16X25
	RXMF-M13A22520	121,150,180,240	2X20X25
MERV 8 Filter	RXMF-M08A11625	090, 120	1X16X25
	RXMF-M08A12025	121,150,180,240	1X20X25
	RXMF-M08A21625	090, 120	2X16X25
	RXMF-M08A22520	121,150,180,240	2X20X25
Electric Heat (* = C, D, or Y Voltage)	RXHE-AG005CA	090, 120	N/A
	RXHE-AG005DA	090, 120	N/A
	RXHE-AG010*A	090, 120	N/A
	RXHE-AG015*A	090, 120	N/A
	RXHE-AG020*A	090, 120	N/A
	RXHE-AG025*A	090, 120	N/A
	RXHE-AG030*A	090, 120	N/A
	RXHE-AG035*A	090, 120	N/A
	RXHE-AG010*C	121, 150, 180, 240	N/A
	RXHE-AG020*C	121, 150, 180, 240	N/A
	RXHE-AG030*C	121, 150, 180, 240	N/A
	RXHE-AG040*C	121, 150, 180, 240	N/A
	RXHE-AG050DC	121, 150, 180, 240	N/A
	RXHE-AG050YC	121, 150, 180, 240	N/A
Economizers for Commercial Air Handler	RXHM-71SA	090, 120	N/A
	RXHM-71LA	121, 150, 180, 240	N/A

R **H** **C** **Y** **A** **2** **090** **C** **A** **R**
1 **2** **3** **4** **5** **6** **789** **10** **11** **12**

1—Brand

R = Rheem

2—Unit Type

H = Air Handler

3—Cabinet Type

C = Commercial

4—Refrigerant

Y = R-454B

5—Heat Type

A = Air Conditioner

6—Airflow Configuration

2 = 2-Stage

7,8,9—Capacity

090 = 7.5 Ton

120 = 10 Ton (Small)

121 = 10 Ton (Large)

150 = 12.5 Ton

180 = 15 Ton

240 = 20 Ton

10—Electrical Designation

C = 208/230 V, 3 PH, 60 Hz

D = 460 V, 3 PH, 60 Hz

Y = 575 V, 3 PH, 60 Hz

11—Minor Series

A = 1st Design

12—Drive

R = Belt Drive—VFD Low Static

S = Belt Drive—VFD Medium Static

T = Belt Drive—VFD High Static

COMMERCIAL SPLIT AIR CONDITIONER MODEL MATCH-UPS

OUTDOOR UNIT MODEL NUMBER	INDOOR AIR HANDLER MODEL NUMBER
RACY2078	RHCYA2090
RACY2090	RHCYA2090
RACY2119	RHCYA2121
RACY2120	RHCYA2120
RACY2150	RHCYA2150
RACY2180	RHCYA2180
RACY2240	RHCYA2240

GENERAL DATA

Model RHCYA2 Series	090C	090D	090Y
			CONTINUED →
Indoor Coil—Fin Type	Louvered	Louvered	Louvered
Tube Type	Rifled	Rifled	Rifled
Tube Size in. [mm]	0.375 [9.5]	0.375 [9.5]	0.375 [9.5]
Face Area sq. ft. [sq. m]	10.2 [0.9]	10.2 [0.9]	10.2 [0.9]
Rows / FPI [FPcm]	4 / 15 [10 / 38]	4 / 15 [10 / 38]	4 / 15 [10 / 38]
Refrigerant Control	TX Valves	TX Valves	TX Valves
Indoor Fan—Type	FC Centrifugal	FC Centrifugal	FC Centrifugal
Diameter in. [mm]	12x12 [305 x 305]	12x12 [305 x 305]	12x12 [305 x 305]
Drive Type	Belt (Adjustable)	Belt (Adjustable)	Belt (Adjustable)
No. Speeds (Standard / VFD)	Single / Multiple	Single / Multiple	Single / Multiple
No. Motors	1	1	1
Motor HP			
R - Low Static Drive	2	2	2
S - Medium Static Drive	2	2	2
T - High Static Drive	3	3	3
Motor RPM	1725	1725	1725
Weights			
Net Weight lbs. [kg]			
R - Low Static Drive	409 [186]	409 [186]	409 [186]
S - Medium Static Drive	409 [186]	409 [186]	409 [186]
T - High Static Drive	419 [190]	419 [190]	419 [190]
Shipping Weight lbs. [kg]			
R - Low Static Drive	429 [195]	429 [195]	429 [195]
S - Medium Static Drive	429 [195]	429 [195]	429 [195]
T - High Static Drive	439 [199]	439 [199]	439 [199]

[] Designates Metric Conversions

GENERAL DATA (CONTINUED)

Model RHCYA2 Series	120C	120D	120Y
			CONTINUED →
Indoor Coil—Fin Type	Louvered	Louvered	Louvered
Tube Type	Rifled	Rifled	Rifled
Tube Size in. [mm]	0.375 [9.5]	0.375 [9.5]	0.375 [9.5]
Face Area sq. ft. [sq. m]	10.2 [0.9]	10.2 [0.9]	10.2 [0.9]
Rows / FPI [FPcm]	4 / 15 [10 / 38]	4 / 15 [10 / 38]	4 / 15 [10 / 38]
Refrigerant Control	TX Valves	TX Valves	TX Valves
Indoor Fan—Type	FC Centrifugal	FC Centrifugal	FC Centrifugal
Diameter in. [mm]	12x12 [305 x 305]	12x12 [305 x 305]	12x12 [305 x 305]
Drive Type	Belt (Adjustable)	Belt (Adjustable)	Belt (Adjustable)
No. Speeds (Standard / VFD)	Single / Multiple	Single / Multiple	Single / Multiple
No. Motors	1	1	1
Motor HP			
R - Low Static Drive	2	2	2
S - Medium Static Drive	2	2	2
T - High Static Drive	3	3	3
Motor RPM	1725	1725	1725
Weights			
Net Weight lbs. [kg]			
R - Low Static Drive	409 [186]	409 [186]	409 [186]
S - Medium Static Drive	409 [186]	409 [186]	409 [186]
T - High Static Drive	419 [190]	419 [190]	419 [190]
Shipping Weight lbs. [kg]			
R - Low Static Drive	429 [195]	429 [195]	429 [195]
S - Medium Static Drive	429 [195]	429 [195]	429 [195]
T - High Static Drive	439 [199]	439 [199]	439 [199]

[] Designates Metric Conversions

GENERAL DATA (CONTINUED)

Model RHCYA2 Series	121C	121D
CONTINUED →		
Indoor Coil—Fin Type	Louvered	Louvered
Tube Type	Rifled	Rifled
Tube Size in. [mm]	0.375 [9.5]	0.375 [9.5]
Face Area sq. ft. [sq. m]	16.5 [1.5]	16.5 [1.5]
Rows / FPI [FPcm]	3 / 15 [8 / 46]	3 / 15 [8 / 46]
Refrigerant Control	TX Valves	TX Valves
Indoor Fan—Type	FC Centrifugal	FC Centrifugal
Diameter in. [mm]	18x15 [457x381]	18x15 [457x381]
Drive Type	Belt (Adjustable)	Belt (Adjustable)
No. Speeds (Standard / VFD)	Single / Multiple	Single / Multiple
No. Motors	1	1
Motor HP		
R - Low Static Drive	2	2
S - Medium Static Drive	2	2
T - High Static Drive	3	3
Motor RPM	1725	1725
Weights		
Net Weight lbs. [kg]		
R - Low Static Drive	575 [261]	575 [261]
S - Medium Static Drive	585 [265]	585 [265]
T - High Static Drive	595 [270]	595 [270]
Shipping Weight lbs. [kg]		
R - Low Static Drive	595 [270]	595 [270]
S - Medium Static Drive	605 [274]	605 [274]
T - High Static Drive	615 [279]	615 [279]

[] Designates Metric Conversions

GENERAL DATA (CONTINUED)

Model RHCYA2 Series	150C	150D	150Y
			CONTINUED →
Indoor Coil—Fin Type	Louvered	Louvered	Louvered
Tube Type	Rifled	Rifled	Rifled
Tube Size in. [mm]	0.375 [9.5]	0.375 [9.5]	0.375 [9.5]
Face Area sq. ft. [sq. m]	16.5 [1.5]	16.5 [1.5]	16.5 [1.5]
Rows / FPI [FPcm]	3 / 15 [8 / 38]	3 / 15 [8 / 38]	3 / 15 [8 / 38]
Refrigerant Control	TX Valves	TX Valves	TX Valves
Indoor Fan—Type	FC Centrifugal	FC Centrifugal	FC Centrifugal
Diameter in. [mm]	18x15 [457x381]	18x15 [457x381]	18x15 [457x381]
Drive Type	Belt (Adjustable)	Belt (Adjustable)	Belt (Adjustable)
No. Speeds (Standard / VFD)	Single / Multiple	Single / Multiple	Single / Multiple
No. Motors	1	1	1
Motor HP			
R - Low Static Drive	2	2	2
S - Medium Static Drive	3	3	3
T - High Static Drive	5	5	5
Motor RPM	1725	1725	1725
Weights			
Net Weight lbs. [kg]			
R - Low Static Drive	575 [261]	575 [261]	575 [261]
S - Medium Static Drive	585 [265]	585 [265]	585 [265]
T - High Static Drive	595 [270]	595 [270]	595 [270]
Shipping Weight lbs. [kg]			
R - Low Static Drive	595 [270]	595 [270]	595 [270]
S - Medium Static Drive	605 [274]	605 [274]	605 [274]
T - High Static Drive	615 [279]	615 [279]	615 [279]

[] Designates Metric Conversions

GENERAL DATA (CONTINUED)

Model RHCYA2 Series	180C	180D	180Y
			CONTINUED →
Indoor Coil—Fin Type	Louvered	Louvered	Louvered
Tube Type	Rifled	Rifled	Rifled
Tube Size in. [mm]	0.375 [9.5]	0.375 [9.5]	0.375 [9.5]
Face Area sq. ft. [sq. m]	16.5 [1.5]	16.5 [1.5]	16.5 [1.5]
Rows / FPI [FPcm]	4 / 15 [10 / 38]	4 / 15 [10 / 38]	4 / 15 [10 / 38]
Refrigerant Control	TX Valves	TX Valves	TX Valves
Indoor Fan—Type	FC Centrifugal	FC Centrifugal	FC Centrifugal
Diameter in. [mm]	18x15 [457x381]	18x15 [457x381]	18x15 [457x381]
Drive Type	Belt (Adjustable)	Belt (Adjustable)	Belt (Adjustable)
No. Speeds (Standard / VFD)	Single / Multiple	Single / Multiple	Single / Multiple
No. Motors	1	1	1
Motor HP			
R - Low Static Drive	2	2	2
S - Medium Static Drive	3	3	3
T - High Static Drive	5	5	5
Motor RPM	1725	1725	1725
Weights			
Net Weight lbs. [kg]			
R - Low Static Drive	690 [313]	690 [313]	690 [313]
S - Medium Static Drive	700 [318]	700 [318]	700 [318]
T - High Static Drive	710 [322]	710 [322]	710 [322]
Shipping Weight lbs. [kg]			
R - Low Static Drive	710 [322]	710 [322]	710 [322]
S - Medium Static Drive	720 [327]	720 [327]	720 [327]
T - High Static Drive	730 [331]	730 [331]	730 [331]

[] Designates Metric Conversions

GENERAL DATA (CONTINUED)

Model RHCYA2 Series	240C	240D	240Y
Indoor Coil—Fin Type	Louvered	Louvered	Louvered
Tube Type	Rifled	Rifled	Rifled
Tube Size in. [mm]	0.375 [9.5]	0.375 [9.5]	0.375 [9.5]
Face Area sq. ft. [sq. m]	16.5 [1.5]	16.5 [1.5]	16.5 [1.5]
Rows / FPI [FPcm]	4 / 15 [10 / 38]	4 / 15 [10 / 38]	4 / 15 [10 / 38]
Refrigerant Control	TX Valves	TX Valves	TX Valves
Indoor Fan—Type	FC Centrifugal	FC Centrifugal	FC Centrifugal
Diameter in. [mm]	18x18 [457x457]	18x18 [457x457]	18x18 [457x457]
Drive Type	Belt (Adjustable)	Belt (Adjustable)	Belt (Adjustable)
No. Speeds (Standard / VFD)	Single / Multiple	Single / Multiple	Single / Multiple
No. Motors	1	1	1
Motor HP			
R - Low Static Drive	5	5	5
S - Medium Static Drive	7.5	7.5	7.5
T - High Static Drive	7.5	7.5	7.5
Motor RPM	1725	1725	1725
Weights			
Net Weight lbs. [kg]			
R - Low Static Drive	700 [318]	700 [318]	700 [318]
S - Medium Static Drive	710 [322]	710 [322]	710 [322]
T - High Static Drive	710 [322]	710 [322]	710 [322]
Shipping Weight lbs. [kg]			
R - Low Static Drive	720 [327]	720 [327]	720 [327]
S - Medium Static Drive	730 [331]	730 [331]	730 [331]
T - High Static Drive	730 [331]	730 [331]	730 [331]

[] Designates Metric Conversions

UNIT DIMENSIONS

Model Number	CONNECTIONS				UNIT					
	Liquid		Vapor		W (Width)		H (Height)		L (Length)	
	Inches	mm	Inches	mm	Inches	mm	Inches	mm	Inches	mm
RHCYA2090	1/2	12.70	1-1/8	28.58	54-1/2	1384.30	27-43/50	707.52	57-17/20	1469.39
RHCYA2120	5/8	15.88	1-3/8	34.93	54-1/2	1384.30	27-43/50	707.52	57-17/20	1469.39
RHCYA2121	5/8	15.88	1-3/8	34.93	61-47/50	1573.28	35-1/10	891.54	78-25/61	1991.59
RHCYA2150	5/8	15.88	1-3/8	34.93	61-47/50	1573.28	35-1/10	891.54	78-25/61	1991.59
RHCYA2180	7/8	22.23	1-5/8	41.28	61-47/50	1573.28	35-1/10	891.54	78-25/61	1991.59
RHCYA2240	7/8	22.23	1-5/8	41.28	61-47/50	1573.28	35-1/10	891.54	78-25/61	1991.59

ELECTRICAL DATA – RHCYA2 SERIES				
		090C	090D	090Y
Unit Information	Unit Operating Voltage Range	187-253	414-506	541-610
	Volts	208/230	460	575
	Minimum Circuit Ampacity			
	R - Low Static Drive	8	4	3
	S - Medium Static Drive	8	4	3
	T - High Static Drive	12	6	5
	Maximum Overcurrent Protection Device Size			
	R - Low Static Drive	15/15	15/15	15/15
	S - Medium Static Drive	15/15	15/15	15/15
	T - High Static Drive	15/20	15/15	15/15
Motor Information	No.	1	1	1
	Volts	208/230	460	575
	Phase	3	3	3
	Rating Plate Amps			
	R - Low Static Drive	6.2	3	2.4
	S - Medium Static Drive	6.2	3	2.4
	T - High Static Drive	9.2	4.6	3.5
	LRA (Amps)			
	R - Low Static Drive	47	24	22.72
	S - Medium Static Drive	47	24	22.72
T - High Static Drive	74.5	38.1	30	

ELECTRICAL DATA – RHCYA2 SERIES

		120C	120D	120Y	121C	121D
Unit Information	Unit Operating Voltage Range	187-253	414-506	541-610	187-253	414-506
	Volts	208/230	460	575	208/230	460
	Minimum Circuit Ampacity					
	R - Low Static Drive	8	4	3	8	4
	S - Medium Static Drive	8	4	3	8	4
	T - High Static Drive	12	6	5	12	6
	Maximum Overcurrent Protection Device Size					
	R - Low Static Drive	15/15	15/15	15/15	15/15	15/15
	S - Medium Static Drive	15/15	15/15	15/15	15/15	15/15
	T - High Static Drive	15/20	15/15	15/15	15/15	15/15
Motor Information	No.	1	1	1	1	1
	Volts	208/230	460	575	208/230	460
	Phase	3	3	3	3	3
	Rating Plate Amps					
	R - Low Static Drive	6.2	3	2.4	6.2	3
	S - Medium Static Drive	6.2	3	2.4	6.2	3
	T - High Static Drive	9.2	4.6	3.5	9.2	4.6
	LRA (Amps)					
	R - Low Static Drive	47	24	22.72	47	24
	S - Medium Static Drive	47	24	22.72	47	24
T - High Static Drive	74.5	38.1	30	74.5	38.1	

ELECTRICAL DATA – RHCYA2 SERIES				
		150C	150D	150Y
Unit Information	Unit Operating Voltage Range	187-253	414-506	541-610
	Volts	208/230	460	575
	Minimum Circuit Ampacity			
	R - Low Static Drive	8	4	3
	S - Medium Static Drive	12	6	5
	T - High Static Drive	16	8	7
	Maximum Overcurrent Protection Device Size			
	R - Low Static Drive	15/15	15/15	15/15
	S - Medium Static Drive	15/15	15/15	15/15
	T - High Static Drive	20/25	15/15	15/15
Motor Information	No.	1	1	1
	Volts	208/230	460	575
	Phase	3	3	3
	Rating Plate Amps			
	R - Low Static Drive	6.2	3	2.4
	S - Medium Static Drive	9.2	4.6	3.5
	T - High Static Drive	12.6	6.3	5.1
	LRA (Amps)			
	R - Low Static Drive	47	24	22.72
	S - Medium Static Drive	74.5	38.1	30
T - High Static Drive	95	47.5	38	

ELECTRICAL DATA – RHCYA2 SERIES

		180C	180D	180Y
Unit Information	Unit Operating Voltage Range	187-253	414-506	541-610
	Volts	208/230	460	575
	Minimum Circuit Ampacity			
	R - Low Static Drive	8	4	3
	S - Medium Static Drive	12	6	5
	T - High Static Drive	16	8	7
	Maximum Overcurrent Protection Device Size			
	R - Low Static Drive	15/15	15/15	15/15
	S - Medium Static Drive	15/15	15/15	15/15
	T - High Static Drive	20/25	15/15	15/15
Motor Information	No.	1	1	1
	Volts	208/230	460	575
	Phase	3	3	3
	Rating Plate Amps			
	R - Low Static Drive	6.2	3	2.4
	S - Medium Static Drive	9.2	4.6	3.5
	T - High Static Drive	12.6	6.3	5.1
	LRA (Amps)			
	R - Low Static Drive	47	24	22.72
	S - Medium Static Drive	74.5	38.1	30
T - High Static Drive	95	47.5	38	

ELECTRICAL DATA – RHCYA2 SERIES				
		240C	240D	240Y
Unit Information	Unit Operating Voltage Range	187-253	414-506	541-610
	Volts	208/230	460	575
	Minimum Circuit Ampacity			
	R - Low Static Drive	16	8	7
	S - Medium Static Drive	24	12	10
	T - High Static Drive	24	12	10
	Maximum Overcurrent Protection Device Size			
	R - Low Static Drive	20/25	15/15	15/15
	S - Medium Static Drive	30/40	15/20	15/15
	T - High Static Drive	30/40	15/20	15/15
Motor Information	No.	1	1	1
	Volts	208/230	460	575
	Phase	3	3	3
	Rating Plate Amps			
	R - Low Static Drive	12.6	6.3	5.1
	S - Medium Static Drive	19.2	9.6	7.7
	T - High Static Drive	19.2	9.6	7.7
	LRA (Amps)			
	R - Low Static Drive	95	47.5	38
	S - Medium Static Drive	127	63.5	58
T - High Static Drive	127	63.5	58	

208/230V THREE PHASE, 60 HZ, AUXILIARY ELECTRIC HEATER KIT CHARACTERISTICS AND APPLICATION

Unit Model Number RHCYA2	Single Power Supply for Both Unit and Heater Kit					Separate Power Supply for Both Unit and Heater Kit			
	Heater Kit			Air Conditioner		Heater Kit		Air Conditioner	
	Model No. RXHE-	Rated Heater kW @ 208/230V	FLA	Unit Min. Ckt. Ampacity	Max. Fuse or Ckt. Bkr. Size	Heater Kit Min. Ckt. Ampacity	Heater Kit Max. Fuse or Ckt. Bkr. Size	Air Cond. Min. Ckt. Ampacity	Air Cond. Max. Fuse or Ckt. Bkr. Size
090CAR 090CAS	AG005CA	3.76/5.00	10.44/12.03	21/23	25/25	14/16	15/20	8/8	15/15
	AG010CA	7.75/9.98	20.82/24.01	34/38	35/40	27/31	30/35	8/8	15/15
	AG015CA	11.27/15.0	31.28/36.08	47/53	50/60	92/106	100/110	8/8	15/15
	AG020CA	15.6/20.2	43.1/48.9	62/69	70/70	54/62	60/70	8/8	15/15
	AG025CA	18.78/25.0	52.13/60.14	73/83	80/90	66/76	70/80	8/8	15/15
	AG030CA	22.0/29.6	60.8/70.2	84/96	90/100	76/88	80/90	8/8	15/15
	AG035CA	26.29/35.0	72.97/84.20	99/113	100/125	92/106	100/110	8/8	15/15
090CAT	AG005CA	3.76/5.00	10.44/12.03	25/27	30/30	14/16	15/20	12/12	20/20
	AG010CA	7.75/9.98	20.82/24.01	38/42	40/45	27/31	30/35	12/12	20/20
	AG015CA	11.27/15.0	31.28/36.08	51/57	60/60	40/46	40/50	12/12	20/20
	AG020CA	15.6/20.2	43.1/48.9	66/73	70/80	54/62	60/70	12/12	20/20
	AG025CA	18.78/25.0	52.13/60.14	77/87	80/900	66/76	70/80	12/12	20/20
	AG030CA	22.0/29.6	60.8/70.2	88/100	90/100	76/88	80/90	12/12	20/20
	AG035CA	26.29/35.0	72.97/84.20	103/117	110/125	92/106	100/110	12/12	20/20
120CAR 120CAS	AG005CA	3.76/5.00	10.44/12.03	21/23	25/25	14/16	15/20	8/8	15/15
	AG010CA	7.75/9.98	20.82/24.01	34/38	35/40	27/31	30/35	8/8	15/15
	AG015CA	11.27/15.0	31.28/36.08	47/53	50/60	40/46	40/50	8/8	15/15
	AG020CA	15.6/20.2	43.1/48.9	62/69	70/70	54/62	60/70	8/8	15/15
	AG025CA	18.78/25.0	52.13/60.14	73/83	80/90	66/76	70/80	8/8	15/15
	AG030CA	22.0/29.6	60.8/70.2	84/96	90/100	76/88	80/90	8/8	15/15
	AG035CA	26.29/35.0	72.97/84.20	99/113	100/125	92/106	100/110	8/8	15/15
120CAT	AG005CA	3.76/5.00	10.44/12.03	25/27	30/30	14/16	15/20	12/12	20/20
	AG010CA	7.75/9.98	20.82/24.01	38/42	40/45	27/31	30/35	12/12	20/20
	AG015CA	11.27/15.0	31.28/36.08	51/57	60/60	40/46	40/50	12/12	20/20
	AG020CA	15.6/20.2	43.1/48.9	66/73	70/80	54/62	60/70	12/12	20/20
	AG025CA	18.78/25.0	52.13/60.14	77/87	80/90	66/76	70/80	12/12	20/20
	AG030CA	22.0/29.6	60.8/70.2	88/100	90/100	76/88	80/90	12/12	20/20
	AG035CA	26.29/35.0	72.97/84.20	103/117	110/125	92/106	100/110	12/12	20/20
121CAR 121CAS	AG010CC	7.50/9.98	20.82/24.01	34/38	35/40	27/31	30/35	8/8	15/15
	AG020CC	14.98/19.95	41.58/47.99	60/68	60/70	52/60	60/60	8/8	15/15
	AG030CC	21.6/28.8	60/70	83/96	90/100	75/88	80/90	8/8	15/15
	AG040CC	30/40	83/96	112/128	125/150	104/120	110/125	8/8	15/15
121CAT	AG010CC	7.50/9.98	20.82/24.01	38/42	40/45	27/31	30/35	12/12	20/20
	AG020CC	14.98/19.95	41.58/47.99	64/72	70/80	52/60	60/60	12/12	20/20
	AG030CC	21.6/28.8	60/70	87/99	90/100	75/88	80/90	12/12	20/20
	AG040CC	30/40	83/96	116/132	125/150	104/120	110/125	12/12	20/20
150CAR	AG010CC	7.50/9.98	20.82/24.01	34/38	35/40	27/31	30/35	8/8	15/15
	AG020CC	14.98/19.95	41.58/47.99	60/68	60/70	52/60	60/60	8/8	15/15
	AG030CC	21.6/28.8	60/70	83/96	90/100	75/88	80/90	8/8	15/15
	AG040CC	30/40	83/96	112/128	125/150	104/120	110/125	8/8	15/15
150CAS	AG010CC	7.50/9.98	20.82/24.01	38/42	40/45	27/31	30/35	12/12	20/20
	AG020CC	14.98/19.95	41.58/47.99	64/72	70/80	52/60	60/60	12/12	20/20
	AG030CC	21.6/28.8	60/70	87/99	90/100	75/88	80/90	12/12	20/20
	AG040CC	30/40	83/96	116/132	125/150	104/120	110/125	12/12	20/20
150CAT	AG010CC	7.50/9.98	20.82/24.01	42/46	45/50	27/31	30/35	16/16	25/25
	AG020CC	14.98/19.95	41.58/47.99	68/76	70/80	52/60	60/60	16/16	25/25
	AG030CC	21.6/28.8	60/70	91/104	100/110	75/88	80/90	16/16	25/25
	AG040CC	30/40	83/96	120/136	125/150	104/120	110/125	16/16	25/25
180CAR	AG010CC	7.50/9.98	20.82/24.01	34/38	35/40	27/31	30/35	8/8	15/15
	AG020CC	14.98/19.95	41.58/47.99	60/68	60/70	52/60	60/60	8/8	15/15
	AG030CC	21.6/28.8	60/70	83/96	90/100	75/88	80/90	8/8	15/15
	AG040CC	30/40	83/96	112/128	125/150	104/120	110/120	8/8	15/15
180CAS	AG010CC	7.50/9.98	20.82/24.01	38/42	40/45	27/31	30/35	12/12	20/20
	AG020CC	14.98/19.95	41.58/47.99	64/72	70/80	52/60	60/60	12/12	20/20
	AG030CC	21.6/28.8	60/70	87/99	90/100	75/88	80/90	12/12	20/20
	AG040CC	30/40	83/96	116/132	125/150	104/120	110/125	12/12	20/20
180CAT	AG010CC	7.50/9.98	20.82/24.01	42/46	45/50	27/31	30/35	16/16	25/25
	AG020CC	14.98/19.95	41.58/47.99	68/76	70/80	52/60	60/60	16/16	25/25
	AG030CC	21.6/28.8	60/70	91/104	100/110	75/88	80/90	16/16	25/25
	AG040CC	30/40	83/96	120/136	125/150	104/120	110/125	16/16	25/25
240CAR 240CAS	AG010CC	7.50/9.98	20.82/24.01	42/46	45/50	27/31	30/35	16/16	25/25
	AG020CC	14.98/19.95	41.58/47.99	68/76	70/80	52/60	60/60	16/16	25/25
	AG030CC	21.6/28.8	60/70	91/104	100/110	75/88	80/90	16/16	25/25
	AG040CC	30/40	83/96	120/136	125/150	104/120	110/125	16/16	25/25
240CAT	AG010CC	7.50/9.98	20.82/24.01	51/55	60/60	27/31	30/35	24/24	40/40
	AG020CC	14.98/19.95	41.58/47.99	76/84	80/90	52/60	60/60	24/24	40/40
	AG030CC	21.6/28.8	60/70	99/112	100/125	75/88	80/90	24/24	40/40
	AG040CC	30/40	83/96	128/144	150/150	104/120	110/125	24/24	40/40

460V THREE PHASE, 60 HZ, AUXILIARY ELECTRIC HEATER KIT CHARACTERISTICS AND APPLICATION

Unit Model Number RHCYA2	Single Power Supply for Both Unit and Heater Kit					Separate Power Supply for Both Unit and Heater Kit			
	Heater Kit			Air Conditioner		Heater Kit		Air Conditioner	
	Model No. RXHE-	Rated Heater kW @ 460V	FLA	Unit Min. Ckt. Ampacity	Max. Fuse or Ckt. Bkr. Size	Heater Kit Min. Ckt. Ampacity	Heater Kit Max. Fuse or Ckt. Bkr. Size	Air Cond. Min. Ckt. Ampacity	Air Cond. Max. Fuse or Ckt. Bkr. Size
090DAR 090DAS	AG005DA	5	6.01	12	15	8	15	4	15
	AG010DA	9.98	12	19	20	15	15	4	15
	AG015DA	15	18.04	27	30	23	25	4	15
	AG020DA	20.2	24.7	35	35	31	35	4	15
	AG025DA	25	30.07	42	45	38	40	4	15
	AG030DA	29.7	35	48	50	44	45	4	15
	AG035DA	35	42.1	57	60	53	60	4	15
090DAT	AG005DA	5	6.01	14	15	8	15	6	15
	AG010DA	9.98	12	21	25	15	15	6	15
	AG015DA	15	18.04	29	30	23	25	6	15
	AG020DA	20.2	24.7	37	40	31	35	6	15
	AG025DA	25	30.07	44	45	38	40	6	15
	AG030DA	29.7	35	50	50	44	45	6	15
	AG035DA	35	42.1	59	60	53	60	6	15
120DAR 120DAS	AG005DA	5	6.01	12	15	8	15	4	15
	AG010DA	9.98	12	19	20	15	15	4	15
	AG015DA	15	18.04	27	30	23	25	4	15
	AG020DA	20.2	24.7	35	35	31	35	4	15
	AG025DA	25	30.07	42	45	38	40	4	15
	AG030DA	29.7	35	48	50	44	45	4	15
	AG035DA	35	42.1	57	60	53	60	4	15
120DAT	AG005DA	5	6.01	14	15	8	15	6	15
	AG010DA	9.98	12	21	25	15	15	6	15
	AG015DA	15	18.04	29	30	23	25	6	15
	AG020DA	20.2	24.7	37	40	31	35	6	15
	AG025DA	25	30.07	44	45	38	40	6	15
	AG030DA	29.7	35	50	50	44	45	6	15
	AG035DA	35	42.1	59	60	53	60	6	15
121DAR 121DAS	AG010DC	9.98	12	19	20	15	15	4	15
	AG020DC	20	24.06	34	35	31	35	4	15
	AG030DC	28.8	35	48	50	44	45	4	15
	AG040DC	40	48	64	70	60	60	4	15
	AG050DC	50	60.14	79	80	76	80	4	15
121DAT	AG010DC	9.98	12	21	25	15	15	6	15
	AG020DC	20	24.06	36	40	31	35	6	15
	AG030DC	28.8	35	50	50	44	45	6	15
	AG040DC	40	48	66	70	60	60	6	15
	AG050DC	50	60.14	81	90	76	80	6	15
150DAR	AG010DC	9.98	12	19	20	15	15	4	15
	AG020DC	20	24.06	34	35	31	35	4	15
	AG030DC	28.8	35	48	50	44	45	4	15
	AG040DC	40	48	64	70	60	60	4	15
	AG050DC	50	60.14	79	80	76	80	4	15
150DAS	AG010DC	9.98	12	21	25	15	15	6	15
	AG020DC	20	24.06	36	40	31	35	6	15
	AG030DC	28.8	35	50	50	44	45	6	15
	AG040DC	40	48	66	70	60	60	6	15
	AG050DC	50	60.14	81	90	76	80	6	15
150DAT	AG010DC	9.98	12	23	25	15	15	8	15
	AG020DC	20	24.06	38	40	31	35	8	15
	AG030DC	28.8	35	52	60	44	45	8	15
	AG040DC	40	48	68	70	60	60	8	15
	AG050DC	50	60.14	84	90	76	80	8	15

460V THREE PHASE, 60 HZ, AUXILIARY ELECTRIC HEATER KIT CHARACTERISTICS AND APPLICATION (CONTINUED)

Unit Model Number RHCYA2	Single Power Supply for Both Unit and Heater Kit					Separate Power Supply for Both Unit and Heater Kit			
	Heater Kit			Air Conditioner		Heater Kit		Air Conditioner	
	Model No. RXHE-	Rated Heater kW @ 460V	FLA	Unit Min. Ckt. Ampacity	Max. Fuse or Ckt. Bkr. Size	Heater Kit Min. Ckt. Ampacity	Heater Kit Max. Fuse or Ckt. Bkr. Size	Air Cond. Min. Ckt. Ampacity	Air Cond. Max. Fuse or Ckt. Bkr. Size
180DAR	AG010DC	9.98	12	19	20	15	15	4	15
	AG020DC	20	24.06	34	35	31	35	4	15
	AG030DC	28.8	35	48	50	44	45	4	15
	AG040DC	40	48	64	70	60	60	4	15
	AG050DC	50	60.14	79	80	76	80	4	15
180DAS	AG010DC	9.98	12	21	25	15	15	6	15
	AG020DC	20	24.06	36	40	31	35	6	15
	AG030DC	28.8	35	50	50	44	45	6	15
	AG040DC	40	48	66	70	60	60	6	15
	AG050DC	50	60.14	81	90	76	80	6	15
180DAT	AG010DC	9.98	12	23	25	15	15	8	15
	AG020DC	20	24.06	38	40	31	35	8	15
	AG030DC	28.8	35	52	60	44	45	8	15
	AG040DC	40	48	68	70	60	60	8	15
	AG050DC	50	60.14	84	90	76	80	8	15
240DAR 240DAS	AG010DC	9.98	12	23	25	15	15	8	15
	AG020DC	20	24.06	38	40	31	35	8	15
	AG030DC	28.8	35	52	60	44	45	8	15
	AG040DC	40	48	68	70	60	60	8	15
	AG050DC	50	60.14	84	90	76	80	8	15
240DAT	AG010DC	9.98	12	27	30	15	15	12	20
	AG020DC	20	24.06	43	45	31	35	12	20
	AG030DC	28.8	35	56	60	44	45	12	20
	AG040DC	40	48	72	80	60	60	12	20
	AG050DC	50	60.14	88	90	76	80	12	20

575V THREE PHASE, 60 HZ, AUXILIARY ELECTRIC HEATER KIT CHARACTERISTICS AND APPLICATION

Unit Model Number RHCYA2	Single Power Supply for Both Unit and Heater Kit					Separate Power Supply for Both Unit and Heater Kit			
	Heater Kit			Air Conditioner		Heater Kit		Air Conditioner	
	Model No. RXHE-	Rated Heater kW @ 575V	FLA	Unit Min. Ckt. Ampacity	Max. Fuse or Ckt. Bkr. Size	Heater Kit Min. Ckt. Ampacity	Heater Kit Max. Fuse or Ckt. Bkr. Size	Air Cond. Min. Ckt. Ampacity	Air Cond. Max. Fuse or Ckt. Bkr. Size
090YAR 090YAS	AG010YA	9.98	10.02	16	20	13	15	3	15
	AG015YA	15	15.06	22	25	19	20	3	15
	AG020YA	20	20.08	29	30	26	30	3	15
	AG025YA	25	25.1	35	35	32	35	3	15
	AG030YA	28.8	28.92	40	40	37	40	3	15
	AG035YA	35	35.14	47	50	44	45	3	15
090YAT	AG010YA	9.98	10.02	17	20	13	15	5	15
	AG015YA	15	15.06	24	25	19	20	5	15
	AG020YA	20	20.08	30	30	26	30	5	15
	AG025YA	25	25.1	36	40	32	35	5	15
	AG030YA	28.8	28.92	41	45	37	40	5	15
	AG035YA	35	35.14	49	50	44	45	5	15
120YAR 120YAS	AG010YA	9.98	10.02	16	20	13	15	3	15
	AG015YA	15	15.06	22	25	19	20	3	15
	AG020YA	20	20.08	29	30	26	30	3	15
	AG025YA	25	25.1	35	35	32	35	3	15
	AG030YA	28.8	28.92	40	40	37	40	3	15
	AG035YA	35	35.14	47	50	44	45	3	15
120YAT	AG010YA	9.98	10.02	17	20	13	15	5	15
	AG015YA	15	15.06	24	25	19	20	5	15
	AG020YA	20	20.08	30	30	26	30	5	15
	AG025YA	25	25.1	36	40	32	35	5	15
	AG030YA	28.8	28.92	41	45	37	40	5	15
	AG035YA	35	35.14	49	50	44	45	5	15
150YAR	AG010YC	9.98	10.02	16	20	13	15	3	15
	AG020YC	20	20.08	29	30	26	30	3	15
	AG030YC	28.8	28.92	40	40	37	40	3	15
	AG040YC	40	40.16	54	60	51	60	3	15
	AG050YC	49.99	50.19	66	70	63	70	3	15
	150YAS	AG010YC	9.98	10.02	17	20	13	15	5
AG020YC		20	20.08	30	30	26	30	5	15
AG030YC		28.8	28.92	41	45	37	40	5	15
AG040YC		40	40.16	55	60	51	60	5	15
AG050YC		49.99	50.19	68	70	63	70	5	15
150YAT		AG010YC	9.98	10.02	19	20	13	15	7
	AG020YC	20	20.08	32	35	26	30	7	15
	AG030YC	28.8	28.92	43	45	37	40	7	15
	AG040YC	40	40.16	57	60	51	60	7	15
	AG050YC	49.99	50.19	70	70	63	70	7	15
	180YAR	AG010YC	9.98	10.02	16	20	13	15	3
AG020YC		20	20.08	29	30	26	30	3	15
AG030YC		28.8	28.92	40	40	37	40	3	15
AG040YC		40	40.16	54	60	51	60	3	15
AG050YC		49.99	50.19	66	70	63	70	3	15
180YAS		AG010YC	9.98	10.02	17	20	13	15	5
	AG020YC	20	20.08	30	30	26	30	5	15
	AG030YC	28.8	28.92	41	45	37	40	5	15
	AG040YC	40	40.16	55	60	51	60	5	15
	AG050YC	49.99	50.19	68	70	63	70	5	15
	180YAT	AG010YC	9.98	10.02	19	20	13	15	7
AG020YC		20	20.08	32	35	26	30	7	15
AG030YC		28.8	28.92	43	45	37	40	7	15
AG040YC		40	40.16	57	60	51	60	7	15
AG050YC		49.99	50.19	70	70	63	70	7	15
240YAR 240YAS		AG010YC	9.98	10.02	19	20	13	15	7
	AG020YC	20	20.08	32	35	26	30	7	15
	AG030YC	28.8	28.92	43	45	37	40	7	15
	AG040YC	40	40.16	57	60	51	60	7	15
	AG050YC	49.99	50.19	70	70	63	70	7	15
	240YAT	AG010YC	9.98	10.02	19	20	13	15	10
AG020YC		20	20.08	32	35	26	30	10	15
AG030YC		28.8	28.92	43	45	37	40	10	15
AG040YC		40	40.16	57	60	51	60	10	15
AG050YC		49.99	50.19	70	70	63	70	10	15

A2L REFRIGERANT INSTALLATION SAFETY DATA

Qmin at Rating Plate Charge Weight [0'-200' 1/2" Line Set]						
RHCYA2		090 [0']	090 [50']	090 [100']	090 [150']	090 [200']
Refrigerant Charge weight (oz)		338.0	388.0	438.0	488.0	538.0
Minimum Total Room Area, TAmin (ft ²)		623.0	715.0	807.0	900.0	992.0
Minimum circulation airflow, Qmin (CFM)		1124.0	1291.0	1457.0	1623.0	1789.0
Installed Altitude (ft above sea level)	Altitude Adjustment Factor	Minimum Total Conditioned Room Area, TAmin (sq ft)				
0	1.000	623	715	807	900	992
1000	1.025	638	733	827	922	1017
2000	1.051	655	751	848	946	1042
3000	1.078	672	771	870	970	1070
4000	1.107	690	792	893	996	1098
5000	1.138	709	813	918	1024	1129
6000	1.170	729	836	944	1053	1161
6500	1.187	739	848	958	1068	1177

Qmin at Rating Plate Charge Weight [0'-200' 5/8" Line Set]						
RHCYA2		120 [0']	120 [50']	120 [100']	120 [150']	120 [200']
Refrigerant Charge weight (oz)		373.5	448.5	523.5	598.5	673.5
Minimum Total Room Area, TAmin (ft ²)		688.0	781.0	873.0	965.0	1057.0
Minimum circulation airflow, Qmin (CFM)		1242.0	1409.0	1575.0	1741.0	1908.0
Installed Altitude (ft above sea level)	Altitude Adjustment Factor	Minimum Total Conditioned Room Area, TAmin (sq ft)				
0	1.000	688	781	873	965	1057
1000	1.025	706	800	894	989	1083
2000	1.051	723	820	917	1014	1111
3000	1.078	742	842	941	1040	1140
4000	1.107	762	864	966	1068	1170
5000	1.138	783	888	993	1098	1203
6000	1.170	805	913	1021	1129	1237
6500	1.187	817	926	1036	1145	1254

A2L REFRIGERANT INSTALLATION SAFETY DATA (CONTINUED)

Qmin at Rating Plate Charge Weight [0'–200' 1/2" Line Set]						
RHCYA2		121 [0']	121 [50']	121 [100']	121 [150']	121 [200']
Refrigerant Charge weight (oz)		328.0	378.0	428.0	478.0	528.0
Minimum Total Room Area, TAmin (ft ²)		605.0	697.0	789.0	881.0	973.0
Minimum circulation airflow, Qmin (CFM)		1091.0	1257.0	1424.0	1590.0	1756.0
Installed Altitude (ft above sea level)	Altitude Adjustment Factor	Minimum Total Conditioned Room Area, TAmin (sq ft)				
0	1.000	605	697	789	881	973
1000	1.025	620	714	808	903	997
2000	1.051	635	732	829	926	1023
3000	1.078	652	751	851	950	1049
4000	1.107	669	771	873	976	1078
5000	1.138	688	793	898	1002	1107
6000	1.170	707	815	923	1031	1139
6500	1.187	717	827	936	1046	1155

Qmin at Rating Plate Charge Weight [0'–200' 5/8" Line Set]						
RHCYA2		150 [0']	150 [50']	150 [100']	150 [150']	150 [200']
Refrigerant Charge weight (oz)		381.5	456.5	531.5	606.5	681.5
Minimum Total Room Area, TAmin (ft ²)		703.2	795.4	887.5	979.7	1071.9
Minimum circulation airflow, Qmin (CFM)		1269.0	1435.0	1602.0	1768.0	1934.0
Installed Altitude (ft above sea level)	Altitude Adjustment Factor	Minimum Total Conditioned Room Area, TAmin (sq ft)				
0	1.000	703	795	888	980	1072
1000	1.025	721	733	827	922	1017
2000	1.051	739	751	848	946	1042
3000	1.078	758	771	870	970	1070
4000	1.107	779	792	893	996	1098
5000	1.138	800	813	918	1024	1129
6000	1.170	823	836	944	1053	1161
6500	1.187	834	848	958	1068	1177

A2L REFRIGERANT INSTALLATION SAFETY DATA (CONTINUED)

Qmin at Rating Plate Charge Weight [0'-200' 5/8" Line Set]						
RHCYA2		180 [0']	180 [50']	180 [100']	180 [150']	180 [200']
Refrigerant Charge weight (oz)		681.5	756.5	831.5	906.5	981.5
Minimum Total Room Area, TAmin (ft ²)		1256.2	1348.3	1440.5	1532.7	1624.8
Minimum circulation airflow, Qmin (CFM)		2267.0	2433.0	2599.0	2766.0	2932.0
Installed Altitude (ft above sea level)	Altitude Adjustment Factor	Minimum Total Conditioned Room Area, TAmin (sq ft)				
0	1.000	1256	1348	1441	1533	1625
1000	1.025	1287	1382	1476	1571	1665
2000	1.051	1320	1417	1514	1611	1707
3000	1.078	1355	1454	1553	1653	1752
4000	1.107	1391	1493	1595	1697	1799
5000	1.138	1429	1534	1639	1744	1849
6000	1.170	1470	1577	1685	1793	1901
6500	1.187	1491	1600	1709	1819	1928

Qmin at Rating Plate Charge Weight [0'-200' 7/8" Line Set]						
RHCYA2		240 [0']	240 [50']	240 [100']	240 [150']	240 [200']
Refrigerant Charge weight (oz)		537.5	692.5	847.5	1002.5	1157.5
Minimum Total Room Area, TAmin (ft ²)		990.8	1082.9	1175.1	1267.2	1359.4
Minimum circulation airflow, Qmin (CFM)		1788.0	1954.0	2120.0	2287.0	2453.0
Installed Altitude (ft above sea level)	Altitude Adjustment Factor	Minimum Total Conditioned Room Area, TAmin (sq ft)				
0	1.000	991	1083	1175	1267	1359
1000	1.025	1015	1110	1204	1299	1393
2000	1.051	1041	1138	1235	1332	1429
3000	1.078	1068	1168	1267	1366	1466
4000	1.107	1097	1199	1301	1403	1505
5000	1.138	1127	1232	1337	1442	1547
6000	1.170	1159	1267	1375	1483	1590
6500	1.187	1176	1285	1394	1504	1613

AIRFLOW PERFORMANCE RHCYA2090 — 7.5 TON [26.4 kW] — 60 Hz — SIDEFLOW

Air Flow CFM [L/s]		External Static Pressure—Inches of Water [kPa]																																							
		0.1 [.02]	0.2 [0.05]	0.3 [0.07]	0.4 [0.10]	0.5 [0.12]	0.6 [0.15]	0.7 [0.17]	0.8 [0.20]	0.9 [0.22]	1.0 [0.25]	1.1 [0.27]	1.2 [0.30]	1.3 [0.32]	1.4 [0.35]	1.5 [0.37]	1.6 [0.40]	1.7 [0.42]	1.8 [0.45]	1.9 [0.47]	2.0 [0.50]																				
2400 [1133]	526	487	581	537	631	581	678	619	720	650	803	788	844	849	884	909	922	967	960	1024	997	1080	1033	1135	1035	1157	1066	1212	1096	1268	1126	1327	1156	1387	1185	1449	1214	1513	1242	1579	
2450 [1156]	533	505	587	555	637	599	683	637	724	668	809	810	850	871	889	932	927	991	965	1049	1001	1106	1036	1162	1040	1187	1070	1244	1101	1302	1131	1362	1160	1424	1189	1488	1218	1553	1246	1620	
2500 [1180]	540	523	594	574	643	618	688	656	728	688	816	833	855	895	894	957	932	1017	969	1075	1005	1133	1040	1189	1044	1219	1075	1277	1105	1337	1135	1399	1164	1463	1193	1528	1222	1595	1250	1664	
2550 [1203]	547	542	600	593	649	637	693	675	732	707	822	822	857	861	921	899	983	937	1043	973	1103	1009	1161	1018	1193	1049	1252	1080	1312	1110	1373	1139	1437	1169	1502	1197	1569	1226	1637	1254	1708
2600 [1227]	555	561	607	612	654	657	698	695	737	728	828	883	867	947	905	1010	942	1071	978	1131	1013	1190	1023	1226	1054	1286	1084	1347	1114	1411	1144	1476	1173	1542	1202	1611	1230	1681	1258	1753	
2650 [1250]	562	581	613	632	660	677	703	716	741	748	834	910	873	975	910	1038	947	1100	983	1161	1017	1221	1028	1259	1059	1321	1089	1384	1119	1449	1148	1516	1177	1584	1206	1654	1234	1726	1262	1800	
2700 [1274]	569	601	620	653	666	698	708	737	746	770	840	938	878	1003	916	1068	952	1131	987	1192	1022	1253	1033	1294	1063	1357	1094	1422	1124	1489	1153	1557	1182	1627	1210	1699	1238	1772	1266	1847	
2750 [1298]	577	622	627	674	672	719	714	759	808	800	847	967	884	1034	921	1099	957	1162	992	1225	1026	1266	1038	1330	1068	1395	1098	1461	1128	1529	1158	1599	1186	1671	1215	1744	1243	1819	—	—	
2800 [1321]	584	634	634	695	678	741	719	781	815	930	853	998	890	1065	927	1131	962	1195	997	1258	1030	1320	1043	1367	1073	1433	1103	1501	1133	1571	1162	1643	1191	1716	1219	1791	1247	1868	—	—	
2850 [1345]	592	665	640	718	684	764	724	804	822	961	859	1030	896	1098	932	1164	967	1229	1001	1293	1034	1356	1048	1405	1078	1473	1108	1543	1138	1614	1167	1687	1195	1762	1224	1839	1251	1917	—	—	
2900 [1368]	600	687	647	740	691	787	730	827	828	994	866	1063	902	1132	938	1199	973	1265	1006	1329	1039	1393	1053	1444	1083	1514	1113	1585	1142	1658	1172	1733	1200	1810	1228	1888	1256	1988	—	—	
2950 [1392]	607	710	654	763	697	810	735	850	835	1027	872	1098	909	1167	944	1235	978	1301	1011	1367	1027	1415	1058	1485	1088	1556	1118	1629	1147	1704	1176	1780	1205	1858	1233	1938	1260	2020	—	—	
3000 [1416]	615	734	661	787	703	834	741	875	842	1062	879	1133	915	1203	949	1272	983	1339	1016	1405	1032	1455	1063	1526	1093	1599	1123	1674	1152	1750	1181	1828	1209	1908	1237	1990	1265	2073	—	—	
3050 [1439]	623	758	668	811	710	859	746	899	849	1098	886	1170	921	1241	955	1310	989	1378	1021	1445	1038	1496	1068	1569	1098	1644	1128	1720	1157	1798	1186	1878	1214	1959	1242	2042	1269	2127	—	—	
3100 [1463]	631	782	675	836	716	884	820	1062	856	1136	892	1208	927	1280	961	1350	994	1419	1026	1486	1043	1539	1074	1613	1104	1689	1133	1767	1162	1847	1191	1928	1219	2011	1247	2096	—	—			
3150 [1486]	638	807	683	861	722	909	827	1100	864	1174	899	1248	933	1320	967	1391	999	1460	1031	1528	1049	1582	1079	1658	1109	1736	1138	1816	1167	1897	1196	1980	1224	2065	1251	2151	—	—			
3200 [1510]	646	833	690	887	729	935	835	1139	871	1214	906	1288	940	1361	973	1433	1005	1503	1036	1572	1054	1627	1084	1705	1114	1784	1143	1865	1172	1948	1201	2033	1229	2119	1256	2207	—	—			
3250 [1534]	654	859	697	914	735	962	842	1179	878	1255	913	1330	946	1404	979	1476	1011	1547	1029	1595	1059	1673	1090	1752	1119	1833	1149	1916	1177	2000	1206	2087	1233	2175	1261	2264	—	—			
3300 [1557]	662	886	704	941	742	989	850	1221	885	1298	919	1373	953	1448	985	1521	1016	1592	1035	1640	1065	1720	1095	1801	1125	1883	1154	1968	1182	2054	1211	2142	1238	2231	1266	2323	—	—			
3350 [1581]	671	913	712	968	749	1017	858	1264	892	1341	926	1418	959	1493	991	1566	1022	1639	1040	1687	1071	1768	1100	1850	1130	1935	1159	2021	1188	2108	1216	2198	1243	2289	—	—	—	—			
3400 [1604]	679	940	719	996	830	1229	866	1308	900	1386	933	1463	966	1539	997	1614	1027	1687	1046	1735	1076	1817	1106	1901	1135	1987	1164	2075	1193	2164	1221	2255	1248	2348	—	—	—	—			

Drive Package	R						S						T											
	0	1	2	3	4	5	0	1	2	3	4	5	0	1	2	3	4	5	0	1	2	3	4	5
Motor H.P. [W]	2 [3728.5]						2 [1491.4]						3 [2237.1]											
Blower Sheave	AK104-3/4						AK71H						AK59											
Motor Sheave	IVL44						IVL44						IVL44											
Belt	A50						A44						A42											
Turns Open	0	1	2	3	4	5	0	1	2	3	4	5	0	1	2	3	4	5	0	1	2	3	4	5
RPM	696	661	627	593	558	646	998	939	874	840	806	840	806	1230	1160	1105	990	927	892	892	892	892	892	892

NOTES: 1. Factory sheave settings are shown in bold type.
 2. Do not set motor sheave below minimum or maximum turns open shown.
 3. Re-adjustment of sheave required to achieve rated airflow at AHR minimum External Static Pressure
 4. Drive data shown is for horizontal airflow with dry coil. Add component resistance (below) to duct resistance to determine total External Static Pressure.

[] Designates Metric Conversions

AIRFLOW PERFORMANCE RHCYA2090 — 7.5 TON [26.4 kW] — 60 Hz — SIDEFLOW (CONTINUED)

Airflow CFM [L/s]	AIRFLOW CORRECTION FACTORS *			COMPONENT AIRFLOW RESISTANCE					
	Total kBtu/h	Sensible kBtu/h	Power kW	Wet Coil		MERV 8 Filter		MERV 13 Filter	
				Resistance Inches of Water [kPa]	Resistance Inches of Water	Resistance Inches of Water	Resistance Inches of Water		
2400 [1133]	0.93	0.73	0.96	0.04 [.01]	0.153	0.157			
2500 [1180]	0.93	0.74	0.96	0.05 [.01]	0.164	0.168			
2600 [1227]	0.94	0.76	0.97	0.05 [.01]	0.175	0.179			
2700 [1274]	0.94	0.78	0.97	0.05 [.01]	0.186	0.189			
2800 [1321]	0.95	0.80	0.97	0.05 [.01]	0.198	0.200			
2900 [1368]	0.95	0.81	0.97	0.06 [.01]	0.209	0.211			
3000 [1416]	0.95	0.83	0.98	0.06 [.01]	0.220	0.221			
3100 [1463]	0.96	0.85	0.98	0.06 [.01]	0.231	0.232			
3200 [1510]	0.96	0.87	0.98	0.06 [.01]	0.242	0.243			
3300 [1557]	0.97	0.88	0.99	0.07 [.02]	0.253	0.254			
3400 [1604]	0.97	0.90	0.99	0.07 [.02]	0.264	0.264			
3500 [1652]	0.98	0.92	0.99	0.07 [.02]	0.276	0.275			
3600 [1711]	0.98	0.93	0.99	0.08 [.02]	0.287	0.286			
3700 [1746]	0.99	0.95	1.00	0.08 [.02]	0.298	0.296			
3800 [1793]	0.99	0.97	1.00	0.08 [.02]	0.309	0.307			
3900 [1840]	1.00	0.99	1.00	0.08 [.02]	0.320	0.318			
4000 [1888]	1.00	1.00	1.01	0.09 [.02]	0.331	0.329			

*Multiply correction factor times gross performance data — resulting sensible capacity cannot exceed total capacity.

[] Designates Metric Conversions

AIRFLOW PERFORMANCE RHCYA2120 — 10 TON [26.4 kW] — 60 Hz — SIDEFLOW

Air Flow CFM [L/s]		External Static Pressure—Inches of Water [kPa]																																						
		0.1 [0.02]	0.2 [0.05]	0.3 [0.07]	0.4 [0.10]	0.5 [0.12]	0.6 [0.15]	0.7 [0.17]	0.8 [0.20]	0.9 [0.22]	1.0 [0.25]	1.1 [0.27]	1.2 [0.30]	1.3 [0.32]	1.4 [0.35]	1.5 [0.37]	1.6 [0.40]	1.7 [0.42]	1.8 [0.45]	1.9 [0.47]	2.0 [0.50]																			
3100 [1463]	—	—	—	—	756	915	793	984	830	1055	866	1129	901	1207	945	1317	980	1376	1012	1436	1042	1498	1070	1561	1183	1828	1213	1895	1238	1959	1259	2021								
3200 [1510]	—	—	—	731	911	768	979	805	1050	841	1124	876	1202	911	1283	959	1382	993	1445	1024	1509	1053	1574	1080	1640	1177	1146	1847	1193	1921	1220	1989	1243	2055	1262	2118				
3300 [1557]	—	—	—	744	975	781	1046	817	1121	852	1198	887	1279	921	1362	973	1452	1005	1519	1035	1586	1063	1655	1089	1725	1112	1797	1133	1869	1172	1944	1202	2018	1227	2088	1248	2155	1265	2220	
3400 [1604]	—	—	—	757	1044	794	1118	829	1195	864	1276	898	1360	953	1459	986	1528	1017	1598	1046	1669	1073	1742	1097	1816	1119	1891	1139	1967	1182	2048	1210	2119	1233	2191	1253	2260	1268	2326	
3500 [1652]	—	—	734	1042	771	1116	807	1194	842	1274	876	1358	909	1444	967	1536	999	1609	1029	1683	1057	1758	1082	1834	1105	1911	1126	1990	1145	2069	1192	2148	1218	2224	1239	2298	1256	2368	1269	2436
3600 [1699]	—	749	1116	785	1193	820	1274	854	1357	888	1444	921	1533	980	1619	1011	1695	1040	1773	1067	1851	1091	1931	1113	2012	1133	2094	1173	2175	1201	2256	1224	2334	1244	2409	1259	2481	1269	2436	
3700 [1746]	—	764	1193	799	1274	834	1357	867	1444	900	1534	961	1628	993	1707	1023	1787	1051	1868	1076	1950	1099	2034	1120	2118	1139	2204	1183	2286	1209	2369	1231	2448	1248	2525	1261	2598	1269	2436	
3800 [1793]	743	1195	779	1275	813	1359	847	1445	880	1535	913	1628	975	1718	1006	1800	1034	1884	1061	1968	1085	2054	1107	2141	1127	2229	1145	2319	1193	2402	1216	2486	1236	2567	1251	2645	1263	2720	1270	2792
3900 [1840]	759	1278	794	1361	828	1448	861	1537	894	1630	956	1728	988	1813	1018	1898	1045	1986	1071	2074	1094	2164	1115	2254	1134	2346	1175	2433	1201	2521	1223	2607	1241	2689	1254	2769	1263	2846	1268	2919
4000 [1888]	775	1365	809	1451	843	1541	876	1634	908	1729	970	1824	1001	1913	1029	2002	1056	2093	1080	2185	1102	2278	1122	2372	1140	2468	1186	2555	1210	2645	1229	2732	1245	2816	1256	2897	1264	2975	1266	3051
4100 [1935]	791	1456	825	1545	858	1638	890	1734	921	1833	983	1926	1013	2018	1041	2111	1066	2206	1089	2301	1110	2398	1129	2496	1145	2595	1195	2681	1217	2773	1235	2862	1249	2947	1258	3030	1263	3110	1264	3186
4200 [1982]	808	1551	841	1643	873	1739	905	1838	966	1938	996	2033	1025	2128	1051	2225	1076	2323	1098	2423	1117	2523	1135	2625	1180	2716	1204	2812	1224	2905	1240	2996	1251	3083	1259	3167	1262	3248	1261	3326
4300 [2029]	825	1650	857	1746	889	1844	920	1946	979	2047	1009	2145	1037	2244	1062	2345	1085	2447	1106	2549	1124	2653	1141	2759	1190	2850	1212	2947	1230	3042	1244	3134	1253	3222	1259	3308	1260	3391	1257	3471
4400 [2076]	842	1753	873	1852	905	1954	962	2060	993	2161	1021	2262	1048	2365	1072	2470	1094	2575	1113	2681	1131	2789	1146	2898	1199	2987	1220	3087	1236	3183	1247	3276	1255	3366	1258	3454	1257	3538	1259	3619
4500 [2123]	859	1860	890	1962	921	2067	976	2176	1005	2280	1033	2385	1058	2492	1081	2600	1102	2709	1120	2819	1137	2930	1186	3026	1208	3129	1226	3230	1240	3328	1240	3423	1256	3515	1257	3603	1254	3689	1247	3772
4600 [2171]	876	1972	907	2077	959	2190	989	2296	1018	2404	1044	2513	1068	2623	1090	2735	1110	2847	1127	2961	1142	3076	1196	3170	1216	3276	1232	3378	1244	3477	1252	3574	1256	3667	1255	3757	1250	3845	1241	3929
4700 [2218]	894	2087	924	2195	973	2312	1003	2422	1030	2534	1055	2646	1078	2760	1099	2875	1117	2992	1134	3109	1148	3228	1205	3319	1224	3426	1238	3530	1248	3631	1254	3729	1255	3824	1252	3916	1245	4004	1234	4090
4800 [2265]	912	2207	956	2327	987	2440	1015	2554	1041	2669	1066	2785	1087	2903	1107	3021	1124	3141	1139	3262	1193	3361	1214	3473	1230	3581	1243	3686	1251	3789	1254	3888	1254	3985	1249	4078	1240	4168	1227	4256
4900 [2312]	939	2341	971	2456	1000	2572	1027	2690	1053	2809	1075	2929	1096	3050	1115	3172	1131	3296	1145	3420	1203	3517	1222	3630	1236	3740	1247	3847	1253	3951	1254	4052	1252	4150	1245	4245	1234	4337	1219	4426
5000 [2359]	954	2472	985	2591	1013	2711	1039	2832	1063	2954	1085	3078	1105	3203	1122	3329	1137	3456	1150	3584	1213	3678	1229	3792	1242	3903	1250	4012	1254	4117	1254	4220	1249	4319	1240	4416	1228	4509	1210	4600
5100 [2407]	969	2608	998	2730	1026	2854	1051	2979	1074	3105	1094	3232	1113	3361	1129	3490	1143	3621	1203	3723	1222	3842	1236	3958	1247	4071	1253	4181	1255	4288	1252	4392	1246	4493	1235	4591	1220	4686	1149	5137

Drive Package	R					S					T				
	1	2	3	4	5	1	2	3	4	5	1	2	3	4	5
Motor H.P. [W]	2 [1491.4]					2 [1491.4]					3 [2237.1]				
Blower Sheave	AK104x3/4					AK84x3/4					AK94x3/4				
Motor Sheave	1VP56x7/8					1VP65x7/8					1VP75x7/8				
Belt	A52					A49					A52				
Turns Open	0	1	2	3	4	0	1	2	3	4	0	1	2	3	4
RPM	894	862	829	797	765	1159	1206	1163	1124	1082	998	1254	1267	1194	1158

NOTES: 1. Factory sheave settings are shown in bold type.
 2. Do not set motor sheave below minimum or maximum turns open shown.
 3. Re-adjustment of sheave required to achieve rated airflow at AHR minimum External Static Pressure
 4. Drive data shown is for horizontal airflow with dry coil. Add component resistance (below) to duct resistance to determine total External Static Pressure.

[] Designates Metric Conversions

AIRFLOW PERFORMANCE RHCYA2120 — 10 TON [26.4 kW] — 60 Hz — SIDEFLOW (CONTINUED)

Airflow CFM [L/s]	AIRFLOW CORRECTION FACTORS *			COMPONENT AIRFLOW RESISTANCE					
	Total kBtu/h	Sensible kBtu/h	Power kW	Wet Coil		MERV 8 Filter		MERV 13 Filter	
				Resistance Inches of Water [kPa]	Resistance Inches of Water	Resistance Inches of Water	Resistance Inches of Water		
3500 [1652]	0.98	0.92	0.99	0.07 [.02]	0.091	0.091	0.098		
3600 [1699]	0.98	0.93	0.99	0.08 [.02]	0.097	0.097	0.103		
3700 [1746]	0.99	0.95	1.00	0.08 [.02]	0.103	0.103	0.109		
3800 [1793]	0.99	0.97	1.00	0.08 [.02]	0.109	0.109	0.115		
3900 [1840]	1.00	0.99	1.00	0.08 [.02]	0.115	0.115	0.121		
4000 [1888]	1.00	1.00	1.01	0.09 [.02]	0.121	0.121	0.127		
4100 [1935]	1.00	1.02	1.01	0.09 [.02]	0.127	0.127	0.132		
4200 [1982]	1.01	1.04	1.01	0.09 [.02]	0.133	0.133	0.138		
4300 [2029]	1.01	1.06	1.01	0.10 [.02]	0.139	0.139	0.144		
4400 [2076]	1.02	1.07	1.02	0.10 [.02]	0.145	0.145	0.150		
4500 [2123]	1.02	1.09	1.02	0.10 [.02]	0.151	0.151	0.156		
4600 [2171]	1.03	1.11	1.02	0.10 [.02]	0.157	0.157	0.161		
4700 [2218]	1.03	1.12	1.03	0.11 [.03]	0.163	0.163	0.167		
4800 [2265]	1.04	1.14	1.03	0.11 [.03]	0.169	0.169	0.173		
4900 [2312]	1.04	1.16	1.03	0.11 [.03]	0.175	0.175	0.179		
5000 [2359]	1.05	1.18	1.03	0.12 [.03]	0.181	0.181	0.185		
5100 [2407]	1.05	1.19	1.04	0.12 [.03]	0.188	0.188	0.190		

*Multiply correction factor times gross performance data — resulting sensible capacity cannot exceed total capacity.

[] Designates Metric Conversions

AIRFLOW PERFORMANCE RHCYA2121 — 10 TON [26.4 kW] — 60 Hz — SIDEFLOW

Air Flow CFM [L/s]		RHCYA2121 Voltage 208/230, 460 — 3 phase 60 Hz																																							
		External Static Pressure—Inches of Water [kPa]																																							
		0.1 [.02]		0.2 [.05]		0.3 [.07]		0.4 [.10]		0.5 [.12]		0.6 [.15]		0.7 [.17]		0.8 [.20]		0.9 [.22]		1.0 [.25]		1.1 [.27]		1.2 [.30]		1.3 [.32]		1.4 [.35]		1.5 [.37]		1.6 [.40]		1.7 [.42]		1.8 [.45]		1.9 [.47]		2.0 [.50]	
		RPM	W	RPM	W	RPM	W	RPM	W	RPM	W	RPM	W	RPM	W	RPM	W	RPM	W	RPM	W	RPM	W	RPM	W	RPM	W	RPM	W	RPM	W	RPM	W	RPM	W	RPM	W	RPM	W		
3200 [1510]	—	—	—	425	596	459	668	494	738	528	805	561	870	589	2285	618	2458	646	2700	673	3009	699	3386	724	3832	748	4345	766	4086	788	4450	810	4917	832	5487	853	6160	873	6936		
3300 [1557]	—	—	—	429	622	463	695	497	766	531	835	564	902	592	2317	621	2503	649	2757	676	3079	701	3469	726	3927	750	4453	768	4172	790	4554	812	5040	834	5628	854	6319	875	7114		
3400 [1604]	—	—	—	433	649	467	724	501	796	535	867	568	935	595	2355	624	2554	651	2820	678	3155	704	3557	728	4028	752	4566	770	4282	792	4662	814	5166	836	5772	856	6482	876	7295		
3500 [1652]	—	—	—	437	678	471	754	505	828	538	899	571	969	598	2397	627	2608	654	2887	680	3235	706	3650	730	4133	749	4039	772	4355	795	4773	816	5295	837	5920	858	6649	878	7480		
3600 [1699]	—	407	628	442	707	476	785	509	860	542	933	575	1004	601	2444	630	2668	657	2960	683	3319	708	3747	732	4242	752	4117	775	4451	797	4888	818	5429	839	6072	860	6819	880	7668		
3700 [1746]	—	412	657	446	738	480	817	513	893	546	968	578	1040	605	2496	633	2732	660	3036	686	3409	711	3849	735	4357	754	4199	777	4551	799	5007	821	5566	841	6227	862	6992	882	7860		
3800 [1793]	—	417	688	451	770	484	850	517	928	550	1004	582	1077	608	2553	636	2801	662	3118	688	3503	713	3955	737	4476	757	4285	779	4655	801	5129	823	5706	844	6386	864	7169	884	8056		
3900 [1840]	—	422	720	455	803	489	885	521	964	554	1041	584	1119	611	2614	639	2875	665	3204	691	3602	716	4067	739	4600	759	4374	782	4763	804	5255	825	5850	846	6548	866	7350	886	8255		
4000 [1888]	—	427	753	460	838	493	920	526	1001	558	1079	586	1159	615	2680	642	2954	668	3296	694	3705	718	4183	741	4729	762	4466	784	4873	806	5384	828	5998	848	6714	868	7534	888	8458		
4100 [1935]	—	432	787	465	873	498	957	530	1039	562	1119	590	1219	618	2751	645	3037	671	3391	697	3814	721	4304	744	4862	765	4562	787	4988	809	5517	830	6149	851	6884	870	7722	890	8664		
4200 [1982]	—	437	822	470	910	503	995	535	1079	566	1160	594	1296	618	2827	649	3125	675	3492	700	3927	724	4430	746	5000	768	4662	790	5106	812	5653	833	6304	853	7057	873	7914	—	—		
4300 [2029]	409	767	442	859	475	948	507	1034	539	1119	571	1201	598	2664	625	2907	652	3218	678	3597	703	4045	726	4560	749	5143	771	4765	793	5228	814	5793	835	6462	856	7234	875	8109	—	—	
4400 [2076]	415	804	448	896	480	987	512	1075	544	1161	575	1244	601	2736	629	2992	656	3316	681	3707	706	4167	729	4695	752	5281	774	4872	796	5353	817	5937	838	6624	858	7414	878	8308	—	—	
4500 [2123]	421	841	453	935	486	1027	517	1116	549	1204	580	1289	605	2813	633	3082	659	3418	685	3822	709	4295	732	4835	754	4587	777	4983	799	5482	820	6084	841	6790	861	7598	880	8510	—	—	

Drive Package	R					S					T							
	1	2	3	4	5	1	2	3	4	5	1	2	3	4	5			
Motor H.P. [W]	2 [3728.5]					2 [3728.5]					3 [3728.5]							
Blower Sheave	BK130H					BK120H					BK105H							
Motor Sheave	1VL40 7/8"					IVP50 7/8"					IVP50 7/8"							
Belt	B52					B52					B50							
Turns Open	0	1	2	3	4	5	0	1	2	3	4	5	0	1	2	3	4	5
RPM	563	541	517	490	463	646	746	939	906	874	840	806	866	1032	997	963	927	892

NOTES: 1. Factory sheave settings are shown in bold type.
2. Do not set motor sheave below minimum or maximum turns open shown.
3. Re-adjustment of sheave required to achieve rated airflow at AHRI minimum External Static Pressure
4. Drive data shown is for horizontal airflow with dry coil. Add component resistance (below) to duct resistance to determine total External Static Pressure.

[] Designates Metric Conversions

AIRFLOW PERFORMANCE RHCYA2121 — 10 TON [26.4 kW] — 60 Hz — SIDEFLOW (CONTINUED)

Airflow CFM [L/s]	AIRFLOW CORRECTION FACTORS *			COMPONENT AIRFLOW RESISTANCE					
	Total kBtu/h	Sensible kBtu/h	Power kW	Wet Coil		MERV 8 Filter		MERV 13 Filter	
				Resistance Inches of Water [kPa]	Resistance Inches of Water	Resistance Inches of Water	Resistance Inches of Water		
3500 [1652]	0.98	0.92	0.99	0.07 [.02]	0.091	0.091	0.098		
3600 [1699]	0.98	0.93	0.99	0.08 [.02]	0.097	0.097	0.103		
3700 [1746]	0.99	0.95	1.00	0.08 [.02]	0.103	0.103	0.109		
3800 [1793]	0.99	0.97	1.00	0.08 [.02]	0.109	0.109	0.115		
3900 [1840]	1.00	0.99	1.00	0.08 [.02]	0.115	0.115	0.121		
4000 [1888]	1.00	1.00	1.01	0.09 [.02]	0.121	0.121	0.127		
4100 [1935]	1.00	1.02	1.01	0.09 [.02]	0.127	0.127	0.132		
4200 [1982]	1.01	1.04	1.01	0.09 [.02]	0.133	0.133	0.138		
4300 [2029]	1.01	1.06	1.01	0.10 [.02]	0.139	0.139	0.144		
4400 [2076]	1.02	1.07	1.02	0.10 [.02]	0.145	0.145	0.150		
4500 [2123]	1.02	1.09	1.02	0.10 [.02]	0.151	0.151	0.156		
4600 [2171]	1.03	1.11	1.02	0.10 [.02]	0.157	0.157	0.161		
4700 [2218]	1.03	1.12	1.03	0.11 [.03]	0.163	0.163	0.167		
4800 [2265]	1.04	1.14	1.03	0.11 [.03]	0.169	0.169	0.173		
4900 [2312]	1.04	1.16	1.03	0.11 [.03]	0.175	0.175	0.179		
5000 [2359]	1.05	1.18	1.03	0.12 [.03]	0.181	0.181	0.185		
5100 [2407]	1.05	1.19	1.04	0.12 [.03]	0.188	0.188	0.190		

*Multiply correction factor times gross performance data — resulting sensible capacity cannot exceed total capacity.

[] Designates Metric Conversions

AIRFLOW PERFORMANCE RHCYA2150 — 12.5 TON [44 kW] — 60 Hz — SIDEFLOW

Air Flow CFM [L/s]		External Static Pressure—Inches of Water [kPa]																																							
		0.1 [0.02]	0.2 [0.05]	0.3 [0.07]	0.4 [0.10]	0.5 [0.12]	0.6 [0.15]	0.7 [0.17]	0.8 [0.20]	0.9 [0.22]	1.0 [0.25]	1.1 [0.27]	1.2 [0.30]	1.3 [0.32]	1.4 [0.35]	1.5 [0.37]	1.6 [0.40]	1.7 [0.42]	1.8 [0.45]	1.9 [0.47]	2.0 [0.50]																				
4200 [1982]	—	—	—	—	502	1033	529	1093	555	1162	582	1239	610	1325	639	1418	661	1538	686	1633	712	1732	738	1836	755	1770	778	1874	801	1986	826	2106	852	2236	878	2374	—	—			
4300 [2029]	—	—	—	482	1015	507	1070	533	1133	560	1205	614	1372	642	1468	664	1562	689	1678	714	1778	741	1882	757	1814	779	1919	803	2033	828	2156	853	2287	880	2427	—	—				
4400 [2076]	—	—	—	487	1053	512	1110	538	1176	564	1250	591	1332	618	1422	645	1521	667	1629	691	1725	717	1826	743	1931	759	1861	781	1988	805	2083	829	2208	855	2341	881	2482	—	—		
4500 [2123]	—	—	—	493	1093	518	1153	543	1221	568	1297	595	1382	621	1475	649	1576	670	1678	694	1772	719	1876	745	1982	761	1910	783	2019	807	2136	831	2262	857	2397	883	2541	—	—		
4600 [2171]	—	—	—	499	1135	523	1197	548	1268	573	1347	599	1434	625	1530	652	1633	673	1729	697	1827	722	1929	747	2035	763	1962	786	2073	809	2192	833	2320	859	2456	885	2602	—	—		
4700 [2218]	—	—	—	481	1123	504	1180	528	1245	553	1318	578	1399	603	1489	629	1587	656	1693	676	1783	700	1881	725	1984	750	2081	765	2017	788	2129	811	2250	835	2380	861	2518	887	2665	—	—
4800 [2265]	—	—	—	487	1168	510	1227	534	1295	558	1370	563	1454	608	1546	634	1647	656	1744	679	1839	703	1938	727	2041	753	2149	768	2074	790	2188	813	2311	838	2443	863	2583	889	2732	—	—
4900 [2312]	—	—	—	493	1215	516	1277	539	1347	563	1425	588	1511	612	1606	638	1709	660	1802	683	1898	706	1997	731	2101	749	2026	771	2134	793	2250	816	2375	840	2508	865	2650	891	2801	—	—
5000 [2359]	—	—	—	500	1265	522	1329	545	1401	569	1482	593	1571	617	1668	642	1773	664	1863	687	1959	710	2059	734	2164	752	2087	773	2196	795	2314	819	2441	843	2576	868	2720	894	2872	—	—
5100 [2407]	484	1259	506	1317	528	1384	551	1458	574	1542	598	1633	622	1733	646	1841	668	1925	690	2022	713	2123	737	2228	755	2151	776	2262	798	2381	821	2510	845	2647	870	2792	896	2947	—	—	
5200 [2454]	491	1311	513	1372	534	1441	557	1518	579	1604	603	1697	627	1800	651	1910	672	1990	694	2088	717	2189	740	2295	758	2217	779	2330	801	2451	824	2581	848	2720	873	2868	899	3024	—	—	
5300 [2501]	498	1365	519	1428	541	1500	563	1580	585	1668	608	1764	632	1869	656	1982	676	2058	698	2156	721	2258	744	2365	761	2286	782	2400	804	2524	827	2656	851	2796	876	2946	—	—			
5400 [2548]	505	1422	526	1488	547	1562	569	1644	591	1735	614	1834	637	1941	660	2033	681	2128	702	2226	724	2329	747	2437	765	2357	785	2474	807	2599	830	2733	854	2875	879	3026	—	—			
5500 [2595]	513	1481	533	1550	554	1626	575	1711	597	1804	619	1906	642	2015	665	2105	685	2200	706	2299	728	2403	751	2511	768	2431	789	2550	811	2677	833	2812	857	2957	882	3110	—	—			
5600 [2643]	520	1543	540	1614	560	1693	581	1780	603	1876	625	1980	647	2092	670	2179	690	2275	711	2375	732	2479	752	2597	772	2508	792	2628	814	2757	837	2895	860	3041	885	3196	—	—			
5700 [2690]	527	1607	547	1681	567	1762	588	1852	609	1950	630	2057	652	2171	674	2255	694	2352	715	2452	737	2557	756	2674	775	2588	796	2710	818	2840	840	2980	864	3128	888	3284	—	—			
5800 [2737]	535	1674	554	1750	574	1834	594	1926	615	2027	636	2136	658	2253	679	2334	699	2431	720	2532	741	2638	759	2755	779	2670	800	2794	821	2926	844	3067	867	3217	892	3375	—	—			

Drive Package	R												S												T													
	1	2	3	4	5	0	1	2	3	4	5	0	1	2	3	4	5	0	1	2	3	4	5	0	1	2	3	4	5	0	1	2	3	4	5			
Motor H.P. [W]	2 [1491.4]																																					
Blower Sheave	BK12OSP 1.0"																																					
Motor Sheave	1VL44 7/8																																					
Belt	B52																																					
Turns Open	0	1	2	3	4	5	0	1	2	3	4	5	0	1	2	3	4	5	0	1	2	3	4	5	0	1	2	3	4	5	0	1	2	3	4	5		
RPM	650	630	606	579	551	522	746	723	699	644	617	597	877	840	803	766	730	694	658	625	592	559	526	750	727	703	679	655	631	607	583	559	535	511	487	463	439	415

- NOTES:** 1. Factory sheave settings are shown in bold type.
 2. Do not set motor sheave below minimum or maximum turns open shown.
 3. Re-adjustment of sheave required to achieve rated airflow at AHR minimum External Static Pressure
 4. Drive data shown is for horizontal airflow with dry coil. Add component resistance (below) to duct resistance to determine total External Static Pressure.

[] Designates Metric Conversions

AIRFLOW PERFORMANCE RHCYA2150 — 12.5 TON [44 kW] — 60 Hz — SIDEFLOW (CONTINUED)

Airflow CFM [L/s]	AIRFLOW CORRECTION FACTORS *			COMPONENT AIRFLOW RESISTANCE					
	Total kBtu/h	Sensible kBtu/h	Power kW	Wet Coil		MERV 8 Filter		MERV 13 Filter	
				Resistance Inches of Water [kPa]	Resistance Inches of Water	Resistance Inches of Water	Resistance Inches of Water		
3500 [1652]	0.98	0.92	0.99	0.07 [.02]	0.091	0.091	0.098		
3600 [1699]	0.98	0.93	0.99	0.08 [.02]	0.097	0.097	0.103		
3700 [1746]	0.99	0.95	1.00	0.08 [.02]	0.103	0.103	0.109		
3800 [1793]	0.99	0.97	1.00	0.08 [.02]	0.109	0.109	0.115		
3900 [1840]	1.00	0.99	1.00	0.08 [.02]	0.115	0.115	0.121		
4000 [1888]	1.00	1.00	1.01	0.09 [.02]	0.121	0.121	0.127		
4100 [1935]	1.00	1.02	1.01	0.09 [.02]	0.127	0.127	0.132		
4200 [1982]	1.01	1.04	1.01	0.09 [.02]	0.133	0.133	0.138		
4300 [2029]	1.01	1.06	1.01	0.10 [.02]	0.139	0.139	0.144		
4400 [2076]	1.02	1.07	1.02	0.10 [.02]	0.145	0.145	0.150		
4500 [2123]	1.02	1.09	1.02	0.10 [.02]	0.151	0.151	0.156		
4600 [2171]	1.03	1.11	1.02	0.10 [.02]	0.157	0.157	0.161		
4700 [2218]	1.03	1.12	1.03	0.11 [.03]	0.163	0.163	0.167		
4800 [2265]	1.04	1.14	1.03	0.11 [.03]	0.169	0.169	0.173		
4900 [2312]	1.04	1.16	1.03	0.11 [.03]	0.175	0.175	0.179		
5000 [2359]	1.05	1.18	1.03	0.12 [.03]	0.181	0.181	0.185		
5100 [2407]	1.05	1.19	1.04	0.12 [.03]	0.188	0.188	0.190		

*Multiply correction factor times gross performance data — resulting sensible capacity cannot exceed total capacity.

[] Designates Metric Conversions

AIRFLOW PERFORMANCE RHCYA2180 — 15 TON [52.7 kW] — 60 Hz — SIDEFLOW (CONTINUED)

Airflow CFM [L/s]	AIRFLOW CORRECTION FACTORS *			COMPONENT AIRFLOW RESISTANCE					
	Total kBtu/h	Sensible kBtu/h	Power kW	Wet Coil		MERV 8 Filter		MERV 13 Filter	
				Resistance Inches of Water [kPa]	Resistance Inches of Water	Resistance Inches of Water	Resistance Inches of Water		
4750 [2241]	1.03	1.13	1.03	0.11 [.03]	0.166	0.170			
4850 [2289]	1.04	1.15	1.03	0.11 [.03]	0.172	0.176			
4950 [2336]	1.04	1.17	1.03	0.11 [.03]	0.178	0.182			
5050 [2383]	1.05	1.19	1.03	0.12 [.03]	0.185	0.188			
5150 [2430]	1.05	1.20	1.04	0.12 [.03]	0.191	0.193			
5250 [2477]	1.06	1.22	1.04	0.12 [.03]	0.197	0.199			
5350 [2525]	1.06	1.24	1.04	0.13 [.03]	0.203	0.205			
5450 [2572]	1.07	1.25	1.05	0.13 [.03]	0.209	0.211			
5550 [2619]	1.07	1.27	1.05	0.13 [.03]	0.215	0.217			
5650 [2666]	1.08	1.29	1.05	0.13 [.03]	0.221	0.222			
5750 [2713]	1.08	1.31	1.05	0.14 [.03]	0.227	0.228			
5850 [2760]	1.08	1.32	1.06	0.14 [.03]	0.233	0.234			
5950 [2808]	1.09	1.34	1.06	0.14 [.03]	0.239	0.240			
6050 [2855]	1.09	1.36	1.06	0.15 [.04]	0.245	0.246			
6150 [2902]	1.10	1.38	1.07	0.15 [.04]	0.251	0.251			
6250 [2949]	1.10	1.39	1.07	0.15 [.04]	0.257	0.257			
6350 [2996]	1.11	1.41	1.07	0.15 [.04]	0.263	0.263			

*Multiply correction factor times gross performance data — resulting sensible capacity cannot exceed total capacity.

[] Designates Metric Conversions

AIRFLOW PERFORMANCE RHCYA2240 — 20 TON [52.7 kW] — 60 Hz — SIDEFLOW (CONTINUED)

Airflow CFM [L/s]	AIRFLOW CORRECTION FACTORS *			COMPONENT AIRFLOW RESISTANCE					
	Total kBtu/h	Sensible kBtu/h	Power kW	Wet Coil		MERV 8 Filter		MERV 13 Filter	
				Resistance Inches of Water [kPa]	Resistance Inches of Water	Resistance Inches of Water	Resistance Inches of Water		
6200 [2926]	1.10	1.38	1.07	0.15 [.04]	0.254	0.254	0.254		
6300 [2973]	1.11	1.40	1.07	0.15 [.04]	0.260	0.260	0.260		
6400 [3020]	1.11	1.42	1.07	0.16 [.04]	0.266	0.266	0.266		
6500 [3067]	1.11	1.44	1.08	0.16 [.04]	0.272	0.272	0.272		
6600 [3114]	1.12	1.45	1.08	0.16 [.04]	0.278	0.278	0.277		
6700 [3162]	1.12	1.47	1.08	0.16 [.04]	0.284	0.284	0.283		
6800 [3209]	1.13	1.49	1.08	0.17 [.04]	0.290	0.290	0.289		
6900 [3256]	1.13	1.51	1.09	0.17 [.04]	0.296	0.296	0.295		
7000 [3303]	1.14	1.52	1.09	0.17 [.04]	0.302	0.302	0.301		
7100 [3350]	1.14	1.54	1.09	0.18 [.04]	0.308	0.308	0.306		
7200 [3398]	1.15	1.56	1.10	0.18 [.04]	0.314	0.314	0.312		
7300 [3445]	1.15	1.57	1.10	0.18 [.04]	0.320	0.320	0.318		
7400 [3492]	1.16	1.59	1.10	0.18 [.04]	0.326	0.326	0.324		
7500 [3539]	1.16	1.61	1.10	0.19 [.05]	0.332	0.332	0.330		
7600 [3586]	1.16	1.63	1.11	0.19 [.05]	0.339	0.339	0.335		
7700 [3633]	1.17	1.64	1.11	0.19 [.05]	0.345	0.345	0.341		
7800 [3681]	1.17	1.66	1.11	0.19 [.05]	0.351	0.351	0.347		

* Multiply correction factor times gross performance data — resulting sensible capacity cannot exceed total capacity.

[] Designates Metric Conversions

RHCYA2 DIMENSIONAL DATA 7.5 AND 10 NOMINAL TONS [26.4 AND 35.2 kW]

REFRIGERANT STUB SIZES, IN. [mm]				
MODEL	DUAL LIQ.	DUAL SUC.	SINGLE LIQ.	SINGLE SUC.
090	1/2, 1/2 [13, 13]	7/8, 7/8 [22, 22]	1/2 [13]	1 1/8 [29]
120	1/2, 1/2 [13, 13]	7/8, 7/8 [22, 22]	5/8 [16]	1 3/8 [35]

MODEL	CORNER WEIGHTS LBS. [kg]				OPERATING WEIGHT	SHIPPING WEIGHT
	A	B	C	D		
090	75.75 [34.36]	133.31 [60.49]	106.04 [48.10]	93.92 [42.60]	409 [185.52]	429 [194.60]
120	75.75 [34.36]	133.31 [60.49]	106.04 [48.10]	93.92 [42.60]	409 [185.52]	429 [194.60]

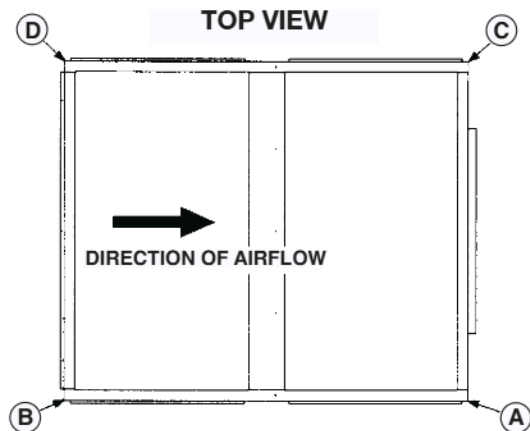

RETURN AIR OPENINGS = 47 3/8" [1203] x 19 7/8" [505] HEIGHT

RETURN AIR OPENINGS = 47 5/8" [1203] WIDTH x 19 7/8" [505] HEIGHT

SIDE VIEW

KNOCK-OUTS BOTH SIDES	
7/8" [22]	12 13/16" [325]
5/8" [16]	10 13/16" [275]
5/8" [16]	8 13/16" [224]
1 1/4" [32]	6 13/16" [173]
1 1/4" x 1 3/4" [32 x 44]	4 9/16" [110]

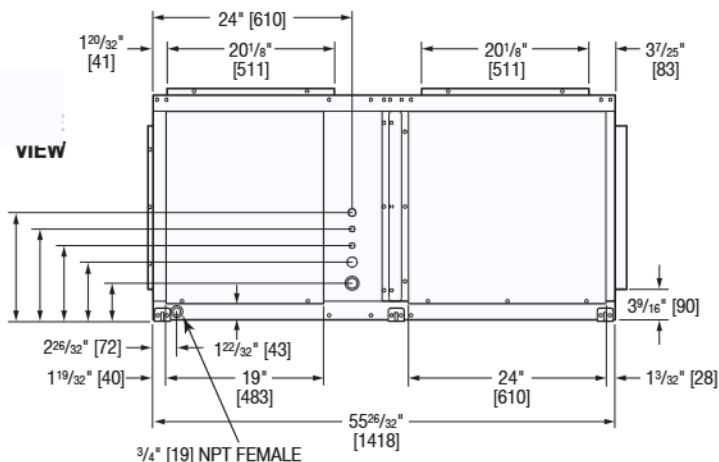

FRONT VIEW

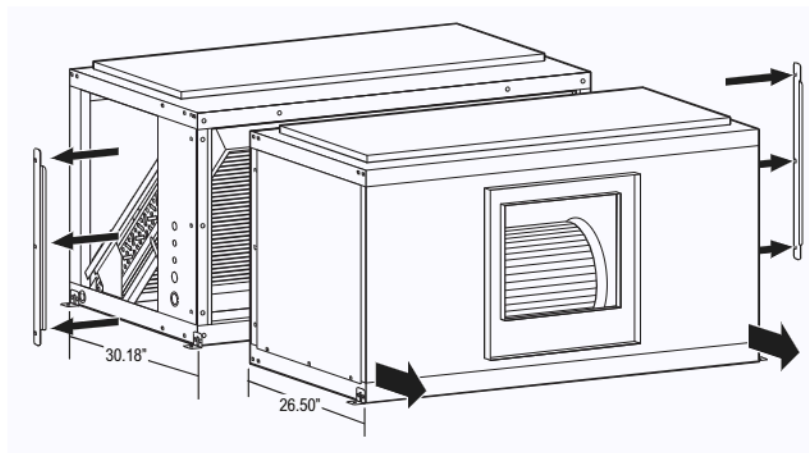
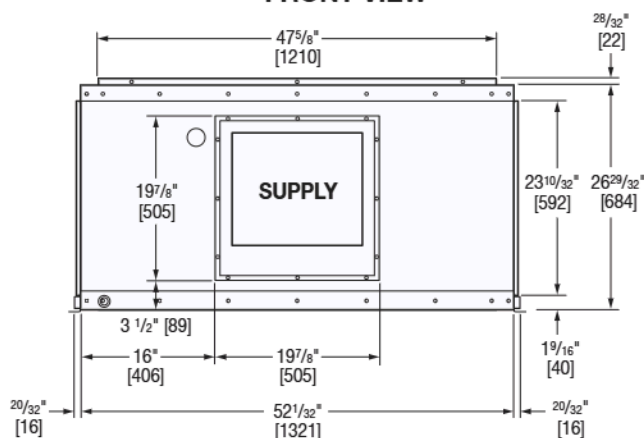

ST-A1372-29-01

ST-A1372-16-01

*Drain connections are provided on both sides of the drain pan. The drain can be connected to either side of the drain pan, but not both. The drain must be trapped.

[] Designates Metric Conversions

RHCYA2 DIMENSIONAL DATA 10, 12.5, 15 & 20 NOMINAL TONS [35.2, 44.0, 52.8 & 70.3 KW]

REFRIGERANT STUB SIZES, IN. [mm]				
MODEL	DUAL LIQ.	DUAL SUC.	SINGLE LIQ.	SINGLE SUC.
121	1/2, 1/2 [13, 13]	1 1/8, 1 1/8 [29, 29]	5/8 [16]	1 5/8 [41]
150	1/2, 1/2 [13, 13]	1 1/8, 1 1/8 [29, 29]	5/8 [16]	1 5/8 [41]
180	5/8, 5/8 [16, 16]	1 3/8, 1 3/8 [35, 35]	7/8 [22]	1 5/8 [41]
240	5/8, 5/8 [16, 16]	1 3/8, 1 3/8 [35, 35]	7/8 [22]	1 5/8 [41]

MODEL	CORNER WEIGHTS LBS. [kg]				OPERATING WEIGHT	SHIPPING WEIGHT
	A	B	C	D		
121	139.42 [63.24]	184.62 [83.74]	79.81 [36.20]	171.15 [77.63]	575 [260.82]	585 [265.35]
150	139.42 [63.24]	184.62 [83.74]	79.81 [36.20]	171.15 [77.63]	575 [260.82]	595 [269.89]
180	227.08 [103.0]	155.93 [70.73]	159.83 [72.50]	147.16 [66.75]	690 [312.98]	710 [322.05]
240	230.37 [104.49]	158.19 [71.75]	162.15 [73.55]	149.29 [67.72]	700 [317.52]	720 [326.59]

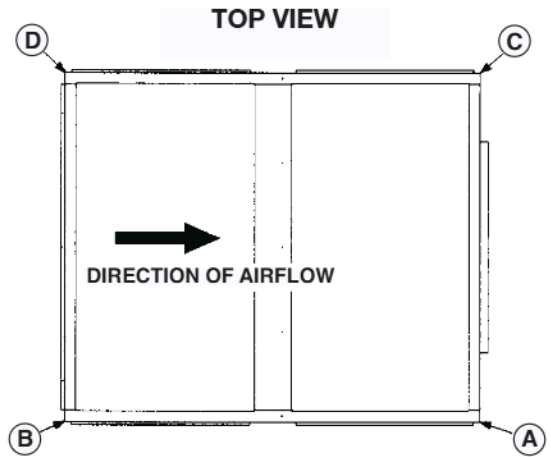

RETURN AIR OPENINGS = 55 1/2" [1410] x 30 9/16" [776] HEIGHT

KNOCK-OUTS BOTH SIDES	
7/8" [22]	18" [457]
7/8" [22]	15" [381]
1 1/4" x 7/8" [32 x 22]	12" [305]
1 3/4" [44]	9" [229]
2" x 1 3/4" [51 x 44]	5 1/2" [140]

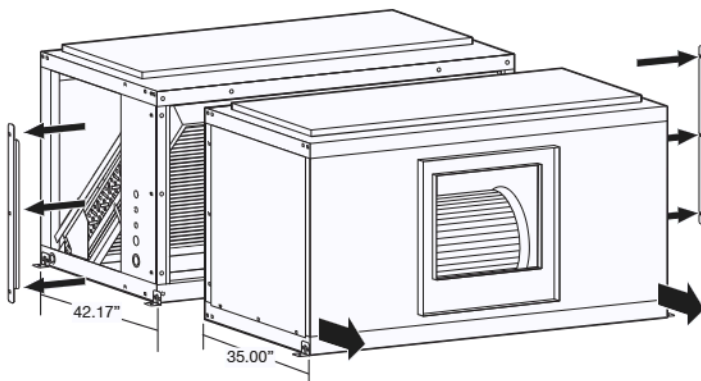
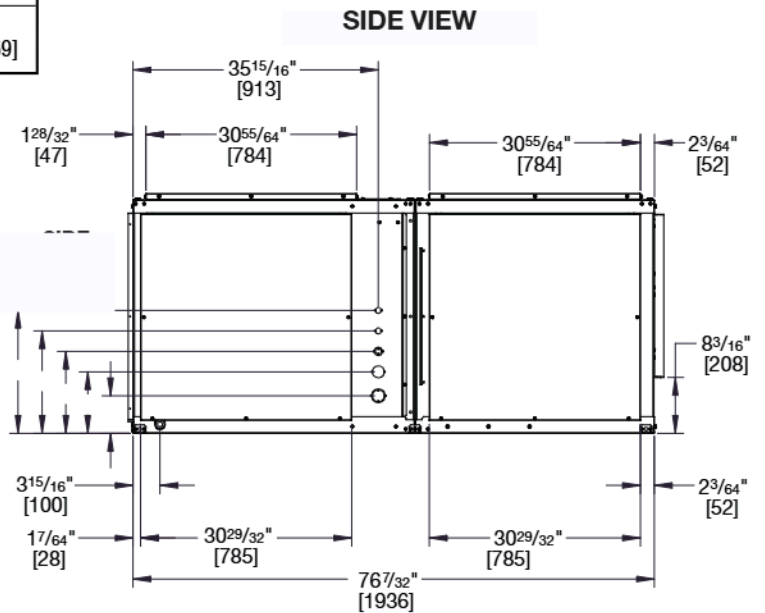

ST-A1372-43-01

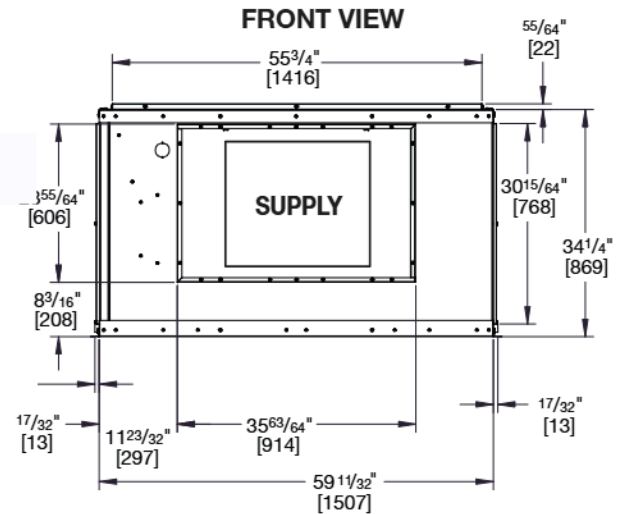

*Drain connections are provided on both sides of the drain pan. The drain can be connected to either side of the drain pan, but not both. The drain must be trapped.

ST-A1372-41-01

[] Designates Metric Conversions

TYPICAL PIPING RECOMMENDATIONS

INDOOR COIL ABOVE OUTDOOR UNIT

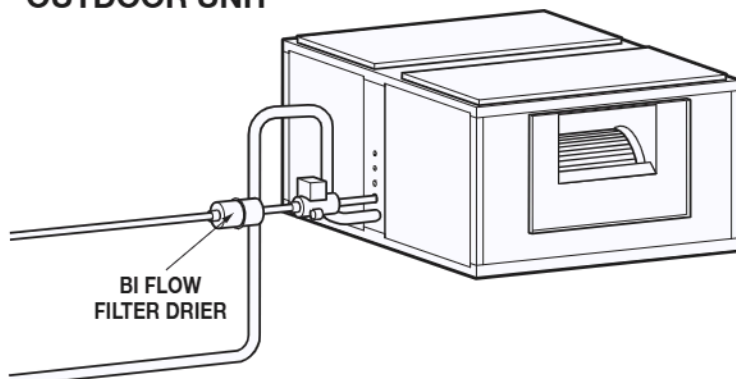

INDOOR COIL BELOW OUTDOOR UNIT

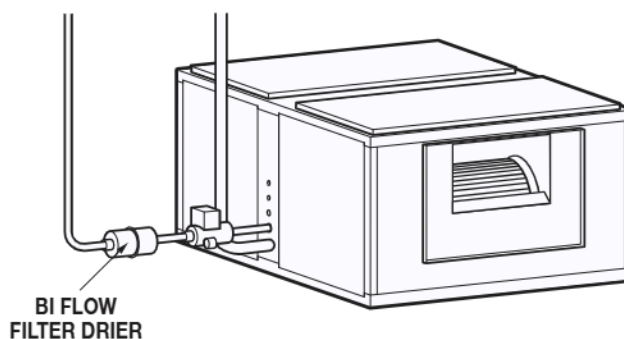

NOTE: PIPING ACCESSORIES SHOWN SHOULD BE MOUNTED AS CLOSE TO AIR HANDLER UNIT AS POSSIBLE

REFRIGERANT PIPING

1. Size liquid line for no more than 50 PSIG pressure drop.
2. Size suction lines for no more than 2°F loss, which corresponds to approximately 5 PSIG pressure drop.
3. When evaporator is installed below condensing unit, do not exceed the recommend-ed suction line O.D. This will insure adequate velocities for proper oil return.
4. Install strainer-drier and sight glass in liquid line.
5. Pitch all horizontal suction lines downward in the direction of flow.
6. When making up refrigerant piping, take every precaution to prevent dirt and moisture from entering the piping.
7. Locate the condensing unit and evaporator(s) as close together as possible to minimize piping runs.
8. A liquid line solenoid installed just ahead of the expansion valve is recommended.
9. See tables below for general refrigerant line sizing and equivalent length of valves and fittings.
10. Refer to the vapor and liquid line selection procedure and charts in the outdoor unit installation manual or literature for more specific refrigerant line sizing information. When dual outdoor units are matched with the air-handler using dual circuits, size the refrigerant lines for each system independently.

CONDENSATE DRAIN PIPING

- Consult local codes or ordinances for specific requirements regarding condensate drain.
- Condensate drain is open to atmosphere and must be trapped. Trap must be at least 3 inches [76 mm] deep and made of flexible material or fabricated to prevent freeze-up.
- Pitch the drain line at least 1/4 inch [6 mm] per foot away from the drain pan.
- Do not reduce the drain line size from the connection size provided on the unit.
- Do not connect the drain line to a closed sewer line.

RECOMMENDED VAPOR AND LIQUID LINE
SIZES FOR VARIOUS LENGTHS OF RUN

LINEAR LENGTH (FT.) [m]	LIQUID LINE O.D. SIZES (IN.) [mm]		VAPOR LINE O.D. SIZES (IN.) [mm]	
	090	120	090	120
0-40 [0-12.19]	1/2 [12.7]	5/8 [15.88]	1 1/8 [28.58]	1 3/8 [34.93]
41-90 [12.5-27.43]	1/2 [12.7]	5/8 [15.88]	1 3/8 [34.93]*	1 3/8 [34.93]*

*NOTE: With the outdoor unit located below the indoor air handler, all vertical vapor lines must not exceed 1 1/8" [28.58 mm] O.D.

[] Designates Metric Conversions

TYPICAL PIPING RECOMMENDATIONS

All models are provided with dual circuit coil manifolds that can be configured for dual condensing unit applications. The coil is circuited to provide full face coil operation for each system. Knock-outs are provided on both sides of the unit to allow the refrigerant tubing to enter from either side. Remove the rubber grommets from the parts bag and install them in the appropriate

holes prior to running the line set tubing into the cabinet to seal around and protect the tubing. Copper fittings are provided in the parts bag to allow the two refrigerant circuits to be tied together for single condensing unit applications. The fittings may be installed to allow the tubing to enter the unit from either side.

REQUIRED OUNCES OF R-454B CHARGE PER FOOT OF TUBING									
Tube Size		Liquid Tube		Vapor Tube		Total		Internal Volume	
OD (in)	OD (mm)	oz/ft	kg/m	oz/ft	kg/m	oz/ft	kg/m	ft ³ /ft	m ³ /m
3/8	9.5	0.5	0.05	0.0	0.00	0.5	0.05	0.000555	0.000048
1/2	12.7	1.0	0.09	0.0	0.00	1.0	0.09	0.001080	0.000093
5/8	15.9	1.5	0.14	0.1	0.00	1.6	0.15	0.001730	0.000149
3/4	19.1	2.2	0.21	0.1	0.01	2.3	0.21	0.002480	0.000214
7/8	22.2	3.1	0.29	0.1	0.01	3.2	0.30	0.003430	0.000296
1	25.4	4.0	0.37	0.1	0.01	4.2	0.39	0.004500	0.000389
1 1/8	28.6	5.2	0.49	0.2	0.02	5.4	0.50	0.005850	0.000503
1 1/4	31.8	6.5	0.60	0.2	0.02	6.7	0.62	0.007210	0.000623
1 3/8	34.9	7.3	0.68	0.2	0.02	7.6	0.70	0.008165	0.000759
1 1/2	38.1	9.4	0.87	0.3	0.03	9.7	0.90	0.010500	0.000910
1 5/8	41.3	11.2	1.04	0.4	0.03	11.6	1.08	0.012500	0.001080
2 1/8	54.0	19.5	1.82	0.6	0.06	20.2	1.88	0.021800	0.001880

SEPARABLE CABINET

For ease of installation into the indoor space, the air handler unit is separable. If required to move into the space, follow the steps below to separate and reconnect the two halves of the air handler.

NOTE: Separation and reconnection should be completed on a flat, stable surface. Do not attempt while unit is suspended from the ceiling.

1. Unscrew and remove the two metal brackets on each side of the air handler.
2. Remove access panels.
3. Remove the 3/8 inch bolts from the frame. The unit can now be pulled apart.
4. Move the air handler into place.
5. If gasketing is damaged, use included replacement gasketing to repair the unit.
6. Align the two sides. Reattach the metal brackets and access panels—these brackets should help align the connecting holes—then insert and fasten the 3/8 inch bolts. The unit can now be reconnected and installation and set-up can commence.

REFRIGERANT LEAK DETECTION

In the event of a detected refrigerant leak, the refrigerant leak detection sensor will trigger a mitigation procedure that shuts off the compressor(s) and turns on the indoor blower motor.

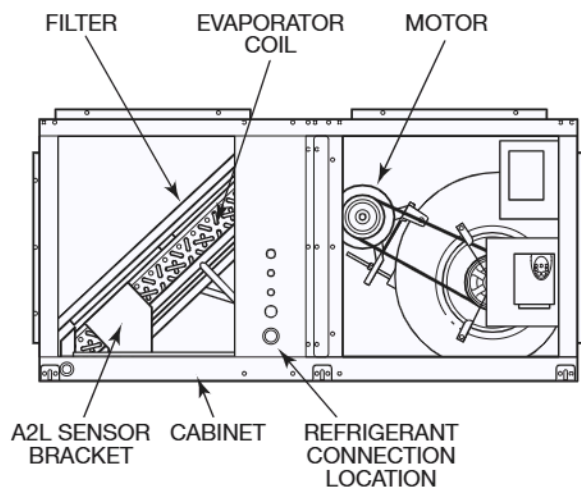

UNIT SHOWN WITH SIDE PANELS REMOVED FOR COIL CONNECTIONS AND AIR FILTER ACCESS.

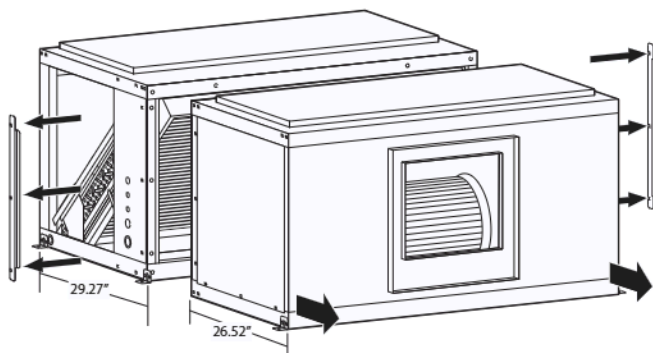

Guide Specifications RHCYA–090-240

You may copy this document directly into your building specification. This specification is written to comply with the 2016 version of the “master format” as published by the Construction Specification Institute. www.csinet.org.

AC AIR HANDLER UNIT

HVAC Guide Specifications

Size Range: 7.5 to 20 Nominal Tons

1.01 Quality Assurance:

- A. Unit shall be rated in accordance with AHRI Standard 340/360.
- B. Unit construction shall comply with ANSI/ASHRAE 15 safety code latest revision and comply with NEC.
- C. Unit shall be constructed in accordance with UL 60335-2-40 standard and shall carry the UL label.
- D. Unit cabinet shall be capable of withstanding 500 hour salt spray exposure per ASTM B117 (scribed specimen).
- E. Unit shall be subjected to run test on the assembly line.
- F. Unit meets ASHRAE 90.1 2022 minimum efficiency requirements.
- G. Insulation and adhesive shall meet NFPA 90A requirements for flame spread and smoke generation.
- H. Unit shall be subjected to a completely automated run test on the assembly line. The data for each unit will be stored at the factory and must be available upon request.

1.02 Manufacturer Qualifications:

- A. Unit shall be manufactured in a facility registered to ISO 9001:2015 manufacturing quality standard.

1.03 Installer Qualifications:

- A. The installer shall be trained to install and service equipment with A2L refrigerants.

1.04 Delivery, Storage, and Handling:

Unit shall be shipped as single package only, and shall be stored and handled according to unit manufacturer’s recommendations.

- A. Unit shall be stored and handled per manufacturer’s recommendations.
- B. Refer to the manufacturer’s installation and operation manual for guidance on how to properly lift the unit.
- C. Unit shall only be stored or positioned in the upright position.

1.05 Unit Cabinet:

- A. Unit cabinet shall be constructed of galvanized steel and coated with a pre-painted baked enamel finish.
- B. Cabinets shall be insulated with 1/2" [13 mm] by 1-1/2 lbs. [.68 kg] density fiberglass insulation coated with neoprene and bonded to the cabinet surface with a U.L. approved adhesive. Insulation shall have fire retarding characteristics in accordance with smoke developed rating not to exceed 50 and flame spread rating of 25 per UL testing procedures.
- C. Unit cabinet exterior paint shall be: pre-painted steel.
- D. Insulation:
 - i. Interior cabinet surfaces shall be insulated with a minimum of 1/2-in. thick, minimum 1.6 lbs. density, flexible fiberglass insulation bonded with foil face on the air side.
 - ii. Insulation and adhesive shall meet NFPA 90A requirements for flame spread and smoke generation.
 - iii. Insulation shall also be mechanically fastened with welded pin and retainer washer.
- E. Condensate Pan and Connections:
 - i. Shall be a sloped condensate drain pan made of a non-corrosive material and be removable for cleaning.
 - ii. Shall comply with ASHRAE Standard 62.
 - iii. Shall use a 3/4" NPT drain connection through either side of the drain pan. The connection shall be made per the manufacturer’s recommendations.
 - iv. Shall have drain connections on each side of the unit in either horizontal or vertical type applications.
- F. Side Panel:
 - i. The separable unit shall have removable side panels on each side of the unit. Each side has two removable panels: four panels total.
- G. Electrical Connections:
 - i. All unit power wiring shall enter the unit cabinet through factory-prepared knockouts next to the unit access panels.
- H. Component Access Panels (Standard):
 - i. Cabinet panels shall be easily opened for servicing.
 - ii. Unit cabinet design shall be separable to facilitate mobilization during installation.

1.06 Refrigerant Components:

- A. The refrigerant circuit shall include the following control, safety, and maintenance features:
 - i. Refrigerant filter drier.
 - ii. Service gauge connections on suction and discharge lines.
 - iii. External pressure gauge ports allows pressures to be checked on the side, without removing access panel.

1.07 Evaporator Coils:

- A. The evaporator coil shall consist of copper tubes with aluminum fins bonded to the tubes by mechanical expansion. Suction and liquid line connections or supply and discharge connections shall be field-configurable to either side of the coil.
- B. Evaporator coil in 12.5 ton units shall be 3-row.
- C. Evaporator coil in 6.5, 7.5, 10, 15, and 20 ton units shall be 4-row.
- D. Direct expansion coils shall feature factory-installed thermostatic expansion valves (TXVs) for refrigerant control. The TXVs shall be R-454B compatible and capable of external adjustment.

1.08 Controls and Safeties:

- A. Components are not compatible between different refrigerants. Do not use R-410A service equipment or components on R-454B equipment. System or part failure could occur.

1.09 Operating Characteristics:

- A. When combined with matching RACY condensing unit, the system shall be capable of starting and running at ambient outdoor temperatures up to 125.6°F (52°C) in cooling mode.
- B. Unit shall be factory configured for horizontal supply & return configurations.
- C. Unit shall be field convertible from vertical to horizontal configuration.

1.10 Electrical Requirements:

- A. Unit shall operate at ±10% from rated voltage.
- B. Unit electrical power shall be single-point connection.
- C. Main power supply voltage, phase, and frequency must match those required by the manufacturer.

1.11 Thermostats:

- A. Thermostat shall:
 - i. Have the capability to energize 2 stages of cooling.
 - ii. The variable speed drive (VFD) must be powered continuously and controlled by the thermostat signals.
 - iii. Use a 3/4" NPT drain connection through either side of the drain pan.
- B. Thermostat Controls:
 - i. The appropriate thermostat control wires (C, G, Y2, W and R) must also be connected to the low voltage terminal block (TB2) located on the outside of the air-handler control box (No heat application).
 - ii. Electric Heat Application - The appropriate thermostat control wires must be connected to the thermostat pigtailed on the heater kit and to the C, G, Y2, and W1 terminals on the low voltage terminal block located on the outside of the air handler control box.
 - iii. Low voltage terminal block (TB3) to be used for A2L sensor. Red wire to "24V VAC/VDC. Brown wire to "24V COM.

1.12 Motor:

- A. Fan motor of the size and electrical characteristics specified on the equipment schedule shall be factory supplied and installed.
- B. Motors shall have inherent thermal overload protection.
- C. Alternate Motor and Drive:
 - i. An alternate motor and/or medium-static or high-static drive shall be available to meet the airflow and external static pressure requirements specified on the equipment schedule.
- D. Variable Frequency Drive (VFD) Standard:
 - i. Unit shall be supplied with an electronic variable frequency drive for the supply air fan.
 - ii. Drive shall be factory installed in an enclosed cabinet.
 - iii. Drive shall meet UL Standard 95-5V.
 - iv. The completed unit assembly shall be UL listed.
 - v. Drives are to be accessible through a tooled access hinged door assembly.
 - vi. The unit manufacturer shall install all power and control wiring.
 - vii. The supply air fan drive output shall be controlled by the factory installed main unit control system and drive status and operating speed shall be monitored and displayed at the main unit control panel.
 - viii. Drive shall be programmed and factory run tested in the unit.

1.13 Special Features:

A. Electric Heaters:

- i. Heaters for nominal 240V, 480V, or 575V, 3-Phase, 60Hz shall be field-installed as shown on the equipment drawings. Electric heat assembly shall be UL agency approved and shall have single-point power wiring.

B. A2L Sensor:

- i. Sensor shall provide the ability to signal the blower, compressor, and electric heat to comply with the UL 60335-2-40 mitigation when a refrigerant leak is detected.
- ii. Sensor shall be operable when the unit is installed in either vertical or horizontal configurations.



GENERAL TERMS OF LIMITED PARTS WARRANTY*

Rheem will furnish a replacement for any part of this product which fails in normal use and service within the applicable periods stated, in accordance with the terms of the limited warranty.

Parts

Commercial ApplicationsOne (1) Year

***For Complete Details of the Limited Warranty, Including Applicable Terms and Conditions, See Your Local Installer or Contact the Manufacturer for a Copy.**

Before proceeding with installation, refer to installation instructions packaged with each model, as well as complying with all Federal, State, Provincial, and Local codes, regulations, and practices.

© 2025 Rheem Manufacturing Company. Rheem trademarks owned by Rheem Manufacturing Company.

In keeping with its policy of continuous progress and product improvement, Rheem reserves the right to make changes without notice.

5600 Old Greenwood Road
Fort Smith, Arkansas 72908 • www.rheem.com

125 Edgeware Road, Unit 1
Brampton, Ontario • L6Y 0P5