

INSTALLATION INSTRUCTIONS

FRONT RETURN AIR HANDLERS

EARTH-FRIENDLY R-454B REFRIGERANT:

(-)F2TY High Efficiency w/Aluminum Coil

(-)F1PY Standard Efficiency w/Aluminum Coil



RECOGNIZE THIS SYMBOL AS AN INDICATION OF IMPORTANT SAFETY INFORMATION!

WARNING

These instructions are intended as an aid to qualified licensed service personnel for proper installation, adjustment and operation of this unit. Read these instructions thoroughly before attempting installation or operation. Failure to follow these instructions may result in improper installation, adjustment, service or maintenance possibly resulting in fire, electrical shock, property damage, personal injury or death.



ISO 9001:2015

DO NOT DESTROY THIS MANUAL

PLEASE READ CAREFULLY AND KEEP IN A SAFE PLACE FOR FUTURE REFERENCE BY A SERVICEMAN

TABLE OF CONTENTS

1.0 SAFETY INFORMATION	4
2.0 GENERAL INFORMATION	6
2.1 IMPORTANT INFORMATION ABOUT EFFICIENCY AND INDOOR AIR QUALITY.....	6
2.2 CHECKING PRODUCT RECEIVED	7
2.3 MODEL NUMBER EXPLANATION.....	8
2.4 AVAILABLE MODELS: J VOLTAGE.....	8
2.5 DIMENSIONS & WEIGHTS	9
2.6 IMPORTANCE OF PROPER INDOOR/OUTDOOR MATCH-UPS.....	10
2.7 IMPORTANCE OF QUALITY INSTALLATION	10
3.0 INSTALLATION	10
3.1 TOOLS & REFRIGERANT.....	10
3.1.1 TOOLS REQUIRED FOR INSTALLING AND SERVICING R-454B MODELS.....	10
3.1.2 SPECIFICATIONS OF R-454B.....	11
3.1.3 QUICK-REFERENCE GUIDE FOR R-454B	11
3.2 APPLICATIONS	11
3.2.1 MOUNTING OPTIONS	11
3.2.1.1 WALL MOUNT.....	12
3.2.1.2 FRAME MOUNT	12
3.2.1.3 FRONT RETURN AIR	12
3.2.1.4 BOTTOM RETURN AIR	12
3.2.2 R-22 AIR-HANDLER REPLACEMENTS.....	13
3.2.3 INSTALLATION IN AN UNCONDITIONED SPACE	13
3.2.4 INSTALLATION IN UNVENTILATED AREAS	14
3.2.5 INSTALLATION IN CORROSIVE ENVIRONMENTS	14
3.3 AUXILIARY OVERFLOW PAN	15
3.4 DRAIN PAN OVERFLOW SWITCH.....	15
3.5 CLEARANCES.....	15
3.6 DUCTWORK.....	15
3.7 RETURN AIR FILTER.....	15
3.8 REFRIGERANT LINE CONNECTIONS & CHARGING	16
3.8.1 PREPARATION	16
3.8.2 LIQUID LINE FILTER DRIER.....	16
3.8.3 BRAZING	16
3.8.4 LEAK TESTING	16
3.8.5 EVACUATION.....	17
3.8.6 REFRIGERANT CHARGING.....	17
3.8.7 REFRIGERANT DETECTION SYSTEM (RDS).....	17
3.8.8 REFRIGERANT DETECTION SYSTEM (RDS) INSTALLATION AND MAINTENANCE	17
3.9 CONDENSATE DRAIN	18
3.10 THERMOSTAT	18
3.11 ELECTRICAL WIRING.....	19
3.11.1 CONFIGURING UNIT FOR 208 VOLT POWER.....	19
3.11.2 GROUNDING.....	19
3.11.3 POWER WIRING	19
3.11.4 COPPER WIRE SIZE - AWG. (3% VOLTAGE DROP).....	19
3.11.5 RF1PY/RF2TY ELECTRICAL DATA - BLOWER MOTOR ONLY NO ELECTRIC HEAT	20
3.11.6 RF1PY/RF2TY ELECTRICAL DATA - WITH ELECTRIC HEAT.....	20
3.11.7 ELECTRIC HEATER SUPPLEMENTAL INFORMATION.....	21
3.11.8 CONTROL WIRING	22
3.11.9 THERMOSTAT & CONTROL WIRING CONNECTIONS	22
3.12 AIR-FLOW PERFORMANCE.....	23
3.12.1 GENERAL AIR-FLOW OPERATING LIMITS.....	24
3.12.2 SELECTING INDOOR BLOWER MOTOR SPEED	24
3.12.2.1 (-)F1PY MODELS (PSC MOTOR).....	24
3.12.2.2 (-)F2PY MODELS (CONSTANT TORQUE ECM MOTOR) - 2 STAGE AIR-FLOW	24
3.12.2.3 (-)F2PY MODELS (CONSTANT TORQUE ECM MOTOR) - SINGLE STAGE AIR-FLOW	24
3.12.3 AIR-FLOW PERFORMANCE DATA	25
3.12.3.1 (-)F1PY (PSC MOTOR).....	25
3.12.3 AIR-FLOW PERFORMANCE DATA (continued).....	26
3.12.3.2 (-)F2TY (CONSTANT TORQUE ECM MOTOR).....	26
4.0 START-UP	27
4.1 PRE-START CHECKLIST.....	27
4.2 SYSTEM START-UP AND OPERATIONAL CHECK-OUT.....	27
4.3 SEQUENCE OF OPERATION.....	27
4.3.1 COOLING MODE.....	27
4.3.2 ELECTRIC HEAT MODE	27
4.3.3 HEAT PUMP HEATING MODE	28
4.3.4 SUPPLEMENTAL ELECTRIC HEAT DURING DEFROST.....	28
4.3.5 EMERGENCY HEAT (HEAT PUMP)	28
4.3.6 THERMOSTAT FAN SETTING.....	28
4.4 CORRECTING ELECTRIC HEAT kW FOR VOLTAGE.....	28
4.5 CALCULATING ELECTRIC HEAT CAPACITY IN BTUH	28

4.6 CHECKING INDOOR AIR-FLOW	28
4.6.1 ESTIMATING CFM USING EXTERNAL STATIC PRESSURE	28
4.6.2 ESTIMATING CFM USING ELECTRIC HEAT TEMPERATURE RISE	29
4.7 CHECKING REFRIGERANT CHARGE	29
5.0 COMPONENTS & CONTROLS	30
5.1 BLOWER MOTOR	30
5.2 MOTOR RUN CAPACITOR	30
5.3 BLOWER CONTROL	30
5.4 BLOWER	31
5.5 TRANSFORMER	31
5.6 INDOOR COIL ASSEMBLY	31
6.0 ACCESSORIES & KITS	32
6.1 ELECTRIC RESISTANCE HEATER KITS	32
6.2 DRAIN PAN OVERFLOW SWITCH KIT	32
6.3 BOTTOM RETURN CONVERSION KIT	33
6.4 LOUVERED CABINET GRILLE	33
6.5 DECORATIVE WALL GRILLE	34
7.0 INDOOR SERVICE/MAINTENANCE	35
7.1 GENERAL GUIDELINES	35
7.2 CHECKS TO THE REFRIGERANT EQUIPMENT	35
7.3 CHECKS TO ELECTRICAL DEVICES	35
7.4 REPAIRS TO SEALED COMPONENTS	35
7.5 REPAIR TO INTRINSICALLY SAFE COMPONENTS	36
7.6 CABLING	36
7.7 DETECTION OF FLAMMABLE REFRIGERANTS	36
7.8 REMOVAL AND EVACUATION	36
7.9 CHARGING PROCEDURES	36
7.10 RECOVERY	36
7.11 DECOMMISSIONING AND LABELING	37
7.12 AIR FILTER	37
7.13 INDOOR COIL, DRAIN PAN, DRAIN LINE	37
7.14 BLOWER MOTOR AND WHEEL	37
7.15 MOTOR LUBRICATION	37
7.16 BLOWER ASSEMBLY, MOTOR, BLOWER WHEEL REMOVAL & REPLACEMENT	37
7.16.1 Small Cabinet Blower Assembly Removal Procedure ((-)F1PY18, (-)F1PY24, AND (-)F2TY24)	38
7.16.2 Large Cabinet Blower Assembly Removal Procedure ((-)F1PY30, (-)F1PY36, AND (-)F2TY36)	39
7.16.3 Large Cabinet Blower MOTOR ONLY Removal Procedure ((-)F1PY30, (-)F1PY36, AND (-)F2TY36)	42
7.16.4 MOTOR REPLACEMENT	44
7.16.5 BLOWER WHEEL REPLACEMENT	44
7.17 REPLACEMENT PARTS	44
8.0 DIAGNOSTICS	45
9.0 WIRING DIAGRAMS	46
9.1 WIRING DIAGRAM (-)F1PY (3-5kW ELECTRIC HEAT)	46
9.2 WIRING DIAGRAM (-)F1PY (8-10kW ELECTRIC HEAT)	47
9.3 WIRING DIAGRAM (-)F2TY (3-5kW ELECTRIC HEAT)	48
9.4 WIRING DIAGRAM (-)F2TY (8-10kW ELECTRIC HEAT)	49
9.5 WIRING DIAGRAM (-)F2TY (230V X-13 MOTOR 2-STAGE)	50
9.6 WIRING DIAGRAM (115V X-13 MOTOR)	51
9.7 WIRING DIAGRAM (PSC MOTOR 115 VOLT)	52
9.8 WIRING DIAGRAM (PSC MOTOR 208/240 VOLT)	53
9.9 WIRING DIAGRAM (230V X-13 MOTOR)	54

1.0 SAFETY INFORMATION

WARNING (SEE SECTION 3.12: ELECTRICAL WIRING)

Disconnect all power to unit before installing or servicing. More than one disconnect switch may be required to de-energize the equipment. Hazardous voltage can cause severe personal injury or death.

WARNING (SEE SECTION 7.5.5: BLOWER WHEEL REPLACEMENT)

If removal of the blower assembly is required, all disconnect switches supplying power to the equipment must be de-energized and locked (if not in sight of unit) so the field power wires can be safely removed from the blower assembly. Failure to do so can cause electrical shock resulting in personal injury or death.

WARNING

Because of possible damage to equipment or personal injury, installation, service, and maintenance should be performed by a trained, qualified service personnel. Consumer service is recommended only for filter cleaning/replacement. Never operate the unit with the access panels removed.

CAUTION

This unit is a **PARTIAL UNIT AIR CONDITIONER**, complying with **PARTIAL UNIT** requirements of this Standard, and must only be connected to other units that have been confirmed as complying to corresponding **PARTIAL UNIT** requirements of this Standard, UL 60335-2-40/CSA C22.2 No. 60335-2-40, or UL 1995/CSA C22.2 No 236.

WARNING

Duct leaks can create an unbalanced system and draw pollutants such as dirt, dust, fumes and odors into the home causing property damage. Fumes and odors from toxic, volatile or flammable chemicals, as well as automobile exhaust and carbon monoxide (CO), can be drawn into the living space through leaking ducts and unbalanced duct systems causing personal injury or death (see Figure 1).

- If air-moving equipment or ductwork is located in garages or off-garage storage areas - all joints, seams, and openings in the equipment and duct must be sealed to limit the migration of toxic fumes and odors including carbon monoxide from migrating into the living space.
- If air-moving equipment or ductwork is located in spaces containing fuel burning appliances such as water heaters or boilers - all joints, seams, and openings in the equipment and duct must also be sealed to prevent depressurization of the space and possible migration of combustion byproducts including carbon monoxide into the living space.

CAUTION

The indoor coil must be equipped with an electronically powered leak detection system. To be effective, the unit must be electrically powered at all times after installation, other than when servicing.

WARNING

These instructions are intended as an aid to qualified, licensed service personnel for proper installation, adjustment and operation of this unit. Read these instructions thoroughly before attempting installation or operation. Failure to follow these instructions may result in improper installation, adjustment, service or maintenance possibly resulting in fire, electrical shock, property damage, personal injury or death.

WARNING (SEE WARNINGS IN REGARD TO DUCTWORK)

Do not install this unit in manufactured (mobile) homes. Improper installation is more likely in manufactured housing due to ductwork material, size, location, and arrangement. Installations in manufactured housing can cause a fire resulting in property damage, personal injury or death.

EXCEPTION: Manufactured housing installations are approved only with documentation by a recognized inspection authority that the installation has been made in compliance with the instructions and all warnings have been observed.

CAUTION

- Single-pole contactors are used on all standard single-phase units through 5 tons. Caution must be exercised when servicing as only one leg of the power supply is broken by the contactor.
- Do not use means to accelerate the defrosting process or to clean, other than those recommended by the manufacturer.
- The appliance shall be stored in a room without continuously operating ignition sources (for example: open flames, an operating gas appliance or an operating electric heater).
- Do not pierce or burn.
- Be aware that refrigerants may not contain an odor.

CAUTION

This appliance is not intended for use by persons (including children) with reduced physical, sensory or mental capabilities, or lack of experience and knowledge, unless they have been given supervision or instruction concerning use of the appliance by a person responsible for their safety. Children should be supervised to ensure that they do not play with the appliance.

The fixed wiring insulation must be protected, for example, by insulating sleeving having an appropriate temperature rating. Any means for disconnection must be incorporated in the fixed wiring in accordance with the wiring rules.

WARNING

PROPOSITION 65: This appliance contains fiberglass insulation. Respirable particles of fiberglass are known to the State of California to cause cancer.

All manufacturer products meet current Federal OSHA Guidelines for safety. California Proposition 65 warnings are required for certain products, which are not covered by the OSHA standards.

California's Proposition 65 requires warnings for products sold in California that contain or produce any of over 600 listed chemicals known to the State of California to cause cancer or birth defects such as fiberglass insulation, lead in brass, and combustion products from natural gas.

All "new equipment" shipped for sale in California will have labels stating that the product contains and/or produces Proposition 65 chemicals. Although we have not changed our processes, having the same label on all our products facilitates manufacturing and shipping. We cannot always know "when, or if" products will be sold in the California market.

You may receive inquiries from customers about chemicals found in, or produced by, some of our heating and air-conditioning equipment, or found in natural gas used with some of our products. Listed below are those chemicals and substances commonly associated with similar equipment in our industry and other manufacturers.

- Glass Wool (Fiberglass) Insulation
- Carbon Monoxide (CO).
- Formaldehyde
- Benzene

More details are available at the websites for OSHA (Occupational Safety and Health Administration), at www.osha.gov and the State of California's OEHHA (Office of Environmental Health Hazard Assessment), at www.oehha.org. Consumer education is important since the chemicals and substances on the list are found in our daily lives. Most consumers are aware that products present safety and health risks, when improperly used, handled and maintained.

WARNING (SEE SECTION 3.2.2: VERTICAL DOWNFLOW)

The RXHB-17, RXHB-21 or RXHB-24 combustible floor base is required when some units with electric heat are applied downflow on combustible flooring. Failure to use the base can cause a fire resulting in property damage, personal injury or death. See **CLEARANCES** for units requiring a combustible floor base. See the accessory section in this manual for combustible floor base RXHB.

WARNING (SEE SECTION 3.12.2: GROUNDING)

The unit must be permanently grounded. Failure to do so can result in electrical shock causing personal injury or death.

WARNING (SEE SECTION 7.0: MAINTENANCE)

Units with circuit breaker(s) meet requirements as a service disconnect switch, however, if access is required to the line side (covered) of the circuit breaker, this side of the breaker(s) will be energized with the breaker(s) de-energized. Contact with the line side can cause electrical shock resulting in personal injury or death.

WARNING (SEE SECTION 3.6: DUCTWORK)

Do not, under any circumstances, connect return ductwork to any other heat producing device such as fireplace insert, stove, etc. Unauthorized use of such devices may result in fire, carbon monoxide poisoning, explosion, personal injury or property damage.

WARNING (SEE SECTION 3.7: AIR FILTER)

Do not operate the system without filters. A portion of the dust entrained in the air may temporarily lodge in the duct runs and at the supply registers. Any circulated dust particles could be heated and charred by contact with the air handler elements. This residue could soil ceilings, walls, drapes, carpets and other articles in the house.

Soot damage may occur with filters in place, when certain types of candles, oil lamps or standing pilots are burned.

CAUTION (SEE SECTION 3.3: AUXILIARY OVERFLOW PAN)

In compliance with recognized codes, it is recommended that an auxiliary drain pan be installed under all evaporator coils or units containing evaporator coils that are located in any area of a structure where damage to the building or building contents may occur as a result of an overflow of the coil drain pan or a stoppage in the primary condensate drain piping.

CAUTION (SEE SECTION 3.2.3: INSTALLATION IN AN UNCONDITIONED SPACE)

When used in cooling applications, excessive sweating may occur when unit is installed in an unconditioned space. This can result in property damage.

NOTICE

Improper installation, or installation not made in accordance with the Underwriters Laboratory (UL) certification or these instructions, can result in unsatisfactory operation and/or dangerous conditions and are not covered by the unit warranty.

NOTICE

Use of this air-handler during construction is not recommended. If operation during construction is absolutely required, the following temporary installation requirements must be followed:







Installation must comply with all Installation Instructions in this manual including the following items:

- Properly sized power supply and circuit breaker/fuse
- Air-handler operating under thermostatic control;
- Return air duct sealed to the air-handler;
- Air filters must be in place;
- Correct air-flow setting for application
- Removing the coil and storing it in a clean safe place is highly recommended until construction is completed and the outdoor unit is installed.
- Clean air-handler, duct work, and components including coil upon completion of the construction process and verify proper air-handler operating conditions according as stated in this instruction manual.
- NOTE: Electric strip heater elements tend to emit a burning odor for a few days if dust has accumulated during construction. Heater elements are easily damaged. Take great care when cleaning them. Low pressure compressed air is recommended for cleaning elements.

NOTICE
 Intended for indoor use only (excluding laundryrooms).

CAUTION
 The fixed wiring insulation must be protected, for example, by insulating sleeving having an appropriate temperature rating. Any means for disconnection must be incorporated in the fixed wiring in accordance with the wiring rules.

Markings Reference

	[Symbol ISO 7000-1659 (2004-01)]	Service indicator: read technical manual
	A2L Symbol	Warning: low burning velocity material
	[Symbol ISO 7000-1701 (2004-01)] (X) Mpa	Pressure
	[Symbol IEC 60417-6040 (2010-08)]	Ultraviolet radiation, instructional safeguard
	[Symbol ISO 7000-1641 (2004-01)]	Operator's manual: operating instructions
	[UN GHS (Globally Harmonized System of Classification and Labeling of Chemicals)]	Refrigerant Safety Group AXX, warning; flammable materials

2.0 GENERAL INFORMATION

2.1 IMPORTANT INFORMATION ABOUT EFFICIENCY AND INDOOR AIR QUALITY

Central cooling and heating equipment is only as efficient as the duct system that carries the cooled or heated air. To maintain efficiency, comfort and good indoor air quality, it is important to have the proper balance between the air being supplied to each room and the air returning to the cooling and heating equipment.

Proper balance and sealing of the duct system improves the efficiency of the heating and air conditioning system and improves the indoor air quality of the home by reducing the amount of airborne pollutants that enter homes from spaces where the ductwork and/or equipment is located. The manufacturer and the U.S. Environmental Protection Agency's Energy Star Program recommend that central duct systems be checked by a qualified contractor for proper balance and sealing.

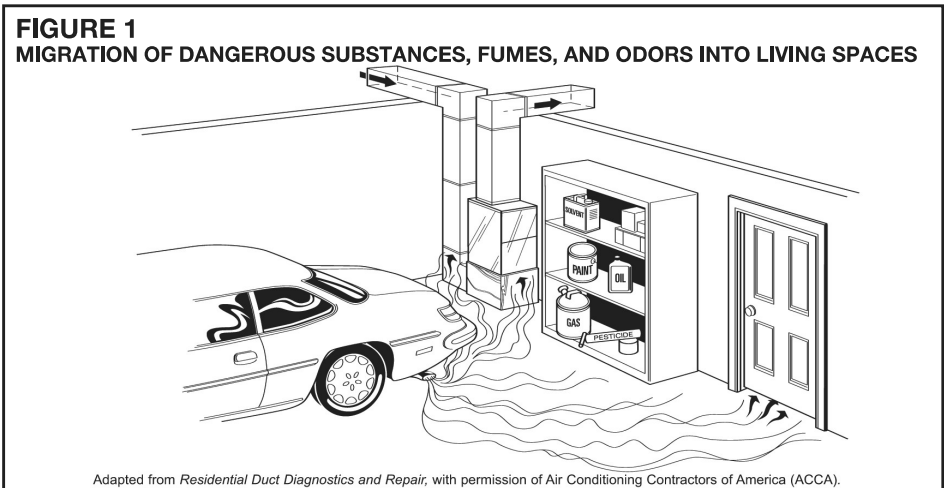

WARNING

Duct leaks can create an unbalanced system and draw pollutants such as dirt, dust, fumes and odors into the home causing property damage. Fumes and odors from toxic, volatile or flammable chemicals, as well as automobile exhaust and carbon monoxide (CO), can be drawn into the living space through leaking ducts and unbalanced duct systems causing personal injury or death (see Figure 1).

- If air-moving equipment or ductwork is located in garages or off-garage storage areas - all joints, seams, and openings in the equipment and duct must be sealed to limit the migration of toxic fumes and odors including carbon monoxide from migrating into the living space.
- If air-moving equipment or ductwork is located in spaces containing fuel burning appliances such as water heaters or boilers - all joints, seams, and openings in the equipment and duct must also be sealed to prevent depressurization of the space and possible migration of combustion byproducts including carbon monoxide into the living space.

NOTICE

Improper installation, or installation not made in accordance with the Underwriters Laboratory (UL) certification or these instructions, can result in unsatisfactory operation and/or dangerous conditions and are not covered by the unit warranty.

2.2 CHECKING PRODUCT RECEIVED

Immediately upon receipt, all cartons and contents should be inspected for transit damage. Units with damaged cartons should be opened immediately. If damage is found, it should be noted on the delivery documents and a damage claim filed with the delivering carrier.

After unit has been delivered to the job site, remove the unit from the carton taking care not to damage the unit. Check the unit rating plate for unit model number, unit size, coil model, voltage, phase, etc. to assure the unit matches the job specifications.

NOTICE

In compliance with recognized codes, it is recommended that an auxiliary drain pan be installed under all evaporator coils or units containing evaporator coils that are located in any area of a structure where damage to the building or building contents may occur as a result of an overflow of the coil drain pan or a stoppage in the primary condensate drain piping.

2.3 MODEL NUMBER EXPLANATION

FIGURE 2
MODEL NUMBER EXPLANATION

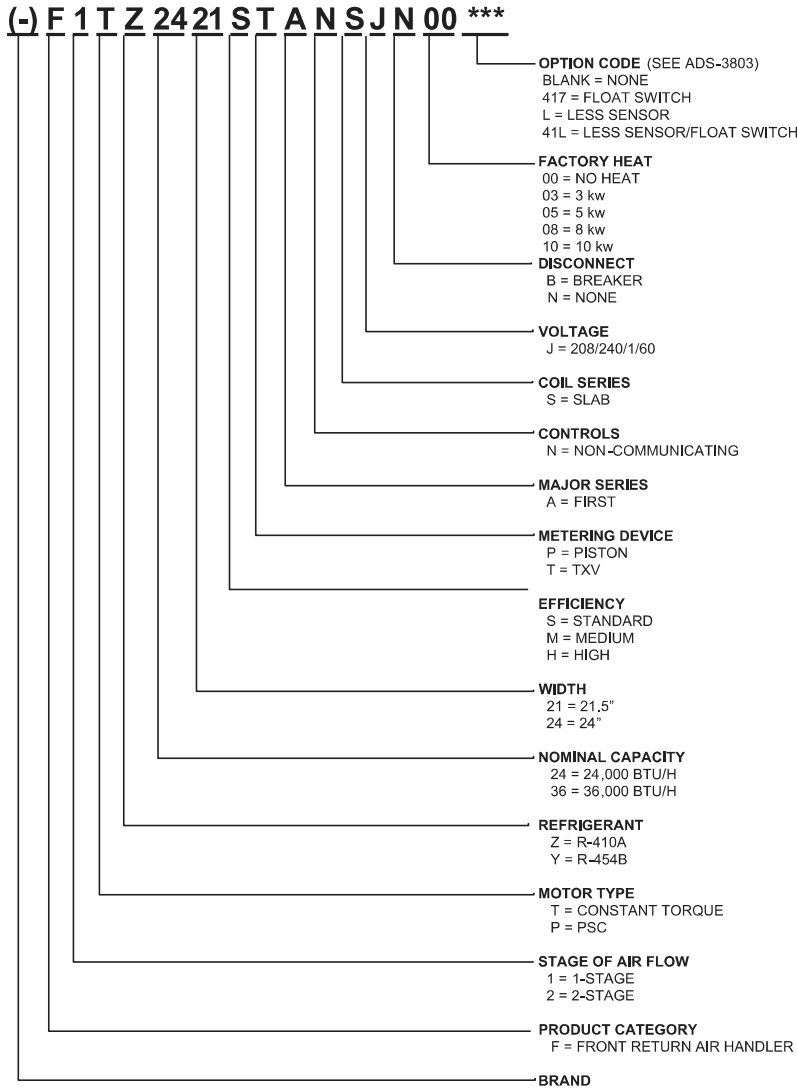

2.4 AVAILABLE MODELS: J VOLTAGE

RF1PY1821STANSJB03	RF2TY2421STANSJB03
RF1PY1821STANSJB05	RF2TY2421STANSJB05
RF1PY1821STANSJB08	RF2TY2421STANSJB08
RF1PY1821STANSJN00	RF2TY2421STANSJB10
RF1PY2421STANSJB03	RF2TY2421STANSJN00
RF1PY2421STANSJB05	RF2TY3624STANSJB03
RF1PY2421STANSJB08	RF2TY3624STANSJB05
RF1PY2421STANSJB10	RF2TY3624STANSJB08
RF1PY2421STANSJN00	RF2TY3624STANSJB10
RF1PY3024STANSJB03	RF2TY3624STANSJN00
RF1PY3024STANSJB05	
RF1PY3024STANSJB08	
RF1PY3024STANSJB10	
RF1PY3024STANSJN00	
RF1PY3624STANSJB03	
RF1PY3624STANSJB05	
RF1PY3624STANSJB08	
RF1PY3624STANSJB10	
RF1PY3624STANSJN00	

2.5 DIMENSIONS & WEIGHTS

FIGURE 3
DIMENSIONS AND WEIGHTS

NOTE: 24" CLEARANCE REQUIRED
IN FRONT OF UNIT FOR FILTER
AND COIL MAINTENANCE.

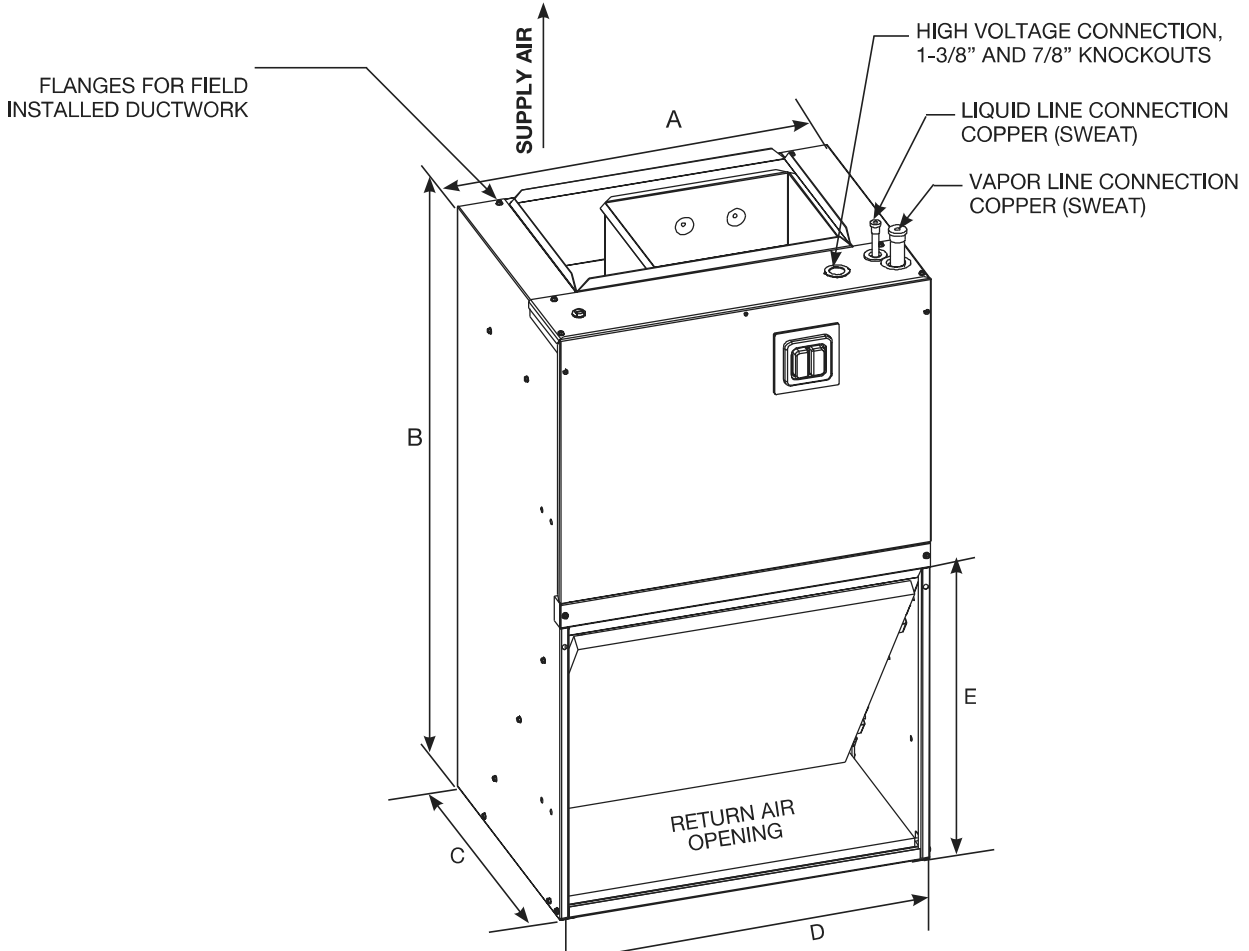

ALL UNITS ARE CONFIGURED FOR VERTICAL UP-FLOW. UNITS CANNOT BE INSTALLED IN ANY OTHER CONFIGURATION.

FRONT RETURN SHOWN. UNITS MAY ALSO BE INSTALLED AS BOTTOM RETURN. SEE THE APPLICATIONS SECTION FOR MORE DETAIL.

DIMENSIONAL DATA

Model	(A) Unit Width In. [mm]	(B) Unit Height In. [mm]	(C) Unit Depth In. [mm]	(D) Return Air Opening Width In. [mm]	(E) Return Air Opening Height In. [mm]	Filter Size in. x in. x in. [mm x mm x mm]	Air-flow CFM (Nom.) [L/s]		Unit Weight/Shipping Weight (Lbs.) [kg]
							Low	High	
RF1PY1821	21 ¹ / ₂ [546.1]	36 [914.4]	17 [431.8]	20 [508]	17 ⁷ / ₁₆ [442.9]	20 X 20 X 1 [508 X 508 X 25.4]	600 [283]	-	80 [36] / 90 [41]
RF1PY2421	21 ¹ / ₂ [546.1]	36 [914.4]	17 [431.8]	20 [508]	17 ⁷ / ₁₆ [442.9]	20 X 20 X 1 [508 X 508 X 25.4]	800 [378]	-	80 [36] / 90 [41]
RF1PY3024	24 [609.6]	36 [914.4]	21 [533.4]	23 [584.2]	21 ³ / ₈ [542.9]	20 X 25 X 1 [508 X 635 X 25.4]	1000 [472]	-	95 [43] x 105 [48]
RF1PY3624	24 [609.6]	36 [914.4]	21 [533.4]	23 [584.2]	21 ³ / ₈ [542.9]	20 X 25 X 1 [508 X 635 X 25.4]	1200 [566]	-	95 [43] x 105 [48]
RF2TY2421	21 ¹ / ₂ [546.1]	36 [914.4]	17 [431.8]	20 [508]	17 ⁷ / ₁₆ [442.9]	20 X 20 X 1 [508 X 508 X 25.4]	600 [283]	800 [378]	95 [43] x 105 [48]
RF2TY3624	24 [609.6]	36 [914.4]	21 [533.4]	23 [584.2]	21 ³ / ₈ [542.9]	20 X 25 X 1 [508 X 635 X 25.4]	1000 [472]	1200 [566]	95 [43] x 105 [48]

[] Designates Metric Conversions

2.6 IMPORTANCE OF PROPER INDOOR/OUTDOOR MATCH-UPS

To assure many years of reliable operation and optimum customer comfort and to assure the outdoor unit warranty remains valid, an air-handler model should be selected that is properly matched to the outdoor unit. This is especially critical for heat pump systems to assure proper refrigerant charge balance between the cooling and heating modes. The recommended approach is to select an air-handler model that has an AHRI match with the outdoor unit. Refer to the AHRI directory at www.ahridirectory.org to confirm the air-handler and outdoor unit are a certified combination in the AHRI Directory.

2.7 IMPORTANCE OF QUALITY INSTALLATION

A quality installation is critical to assure safety, reliability, comfort, and customer satisfaction. Strict adherence to applicable codes, the information in this installation manual, the outdoor unit installation manual, and the thermostat installation manual are key to a quality installation. Read the entire instruction manuals before starting the installation.

IMPORTANT: This product has been designed and manufactured to meet certified AHRI capacity and efficiency ratings with the appropriate outdoor units. However, proper refrigerant charge, proper air-flow, and refrigerant line sizing are critical to achieve optimum capacity and efficiency and to assure reliable operation. Installation of this product should follow the manufacturer's refrigerant charging and air-flow instructions located in the outdoor unit installation instructions and the charging chart label affixed to the outdoor unit. Failure to confirm proper charge and air-flow may reduce energy efficiency and shorten equipment life.

The equipment has been evaluated in accordance with the Code of Federal Regulations, Title 24, Chapter XX, Part 3280.

Install the unit in accordance with applicable national, state, and local codes. Latest editions are available from: "National Fire Protection Association, Inc., Batterymarch Park, Quincy, MA 02269." These publications are:

- ANSI/NFPA No. 70-(Latest Edition) National Electrical Code.
- NFPA 90A Installation of Air Conditioning and Ventilating Systems.
- NFPA 90B Installation of Warm Air Heating and Air-Conditioning Systems.

Install the unit in such a way as to allow necessary access to the coil/filter rack and blower/control compartment.

3.0 INSTALLATION

3.1 TOOLS & REFRIGERANT

3.1.1 TOOLS REQUIRED FOR INSTALLING AND SERVICING R-454B MODELS

Manifold Sets:

- Up to 800 PSIG High-Side
- Up to 250 PSIG Low-Side
- 550 PSIG Low-Side Retard

Manifold Hoses:

- Service Pressure Rating of 800 PSIG

Recovery Cylinders:

- 400 PSIG Pressure Rating
- Dept. of Transportation 4BA400 or 4BW400

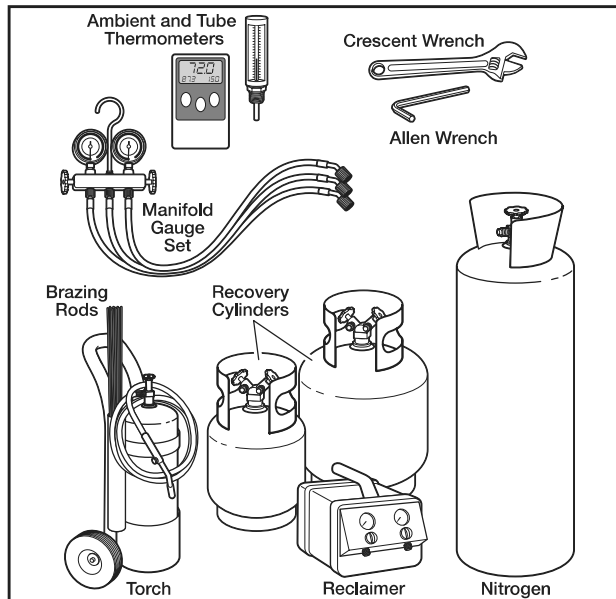

▲ NOTICE

R-454B is classified as safety group A2L per ASHRAE Standard 34. Verify that service equipment and instruments are certified for use with group A2L refrigerants, and in particular with R-454B.

3.1.2 SPECIFICATIONS OF R-454B

Application: **R-454B is not a drop-in replacement for R-410A.** Equipment design must accommodate the safety group A2L of R-454B. It cannot be retrofitted into R-410A systems.

Physical Properties: R-454B has an atmospheric bubble point of $-59.6\text{ }^{\circ}\text{F}$ [$-50.9\text{ }^{\circ}\text{C}$] and an atmospheric dew point of $-58.0\text{ }^{\circ}\text{F}$ [$-50.0\text{ }^{\circ}\text{C}$]. Its bubble point saturation pressure at $77\text{ }^{\circ}\text{F}$ [$25\text{ }^{\circ}\text{C}$] is 213 psig [1469 kPa] and dew point saturation pressure at $77\text{ }^{\circ}\text{F}$ [$25\text{ }^{\circ}\text{C}$] is 205 psig [1415 kPa].

Composition: R-454B is classified as safety group A2L per ASHRAE Standard 34. Verify that service equipment and instruments are certified for use with group A2L refrigerants, and in particular with R-454B is a non-azeotropic mixture of 68.9% by weight difluoromethane (HFC-32) and 31.1% by weight 2,3,3,3-tetrafluoro-1-propene (HFO-1234yf).

Pressure: The pressure of R-454B is classified as safety group A2L per ASHRAE Standard 34. Verify that service equipment and instruments are certified for use with group A2L refrigerants, and in particular with R-454B is similar to that of R-410A. Recovery and recycle equipment, pumps, hoses, and the like must have design pressure ratings appropriate for R-454B. Manifold sets need to range up to 800 psig high-side and 250 psig low-side with a 550 psig low-side retard. Hoses need to have a service pressure rating of 800 psig. Recovery cylinders need to have a 400 psig service pressure rating, DOT 4BA400 or DOT 4BW400.

Flammability: R-454B is classified as safety group A2L, where the 2L flammability class indicates lower flammability. **R-454B and air should never be mixed in tanks or supply lines or be allowed to accumulate in storage tanks. Leak checking should never be done with a mixture of R-454B and air.**

3.1.3 QUICK-REFERENCE GUIDE FOR R-454B

- Refrigerant R-454B operates at pressures similar to R-410A. However, it is classified in safety group A2L. Ensure that servicing equipment is compatible with R-454B.
- Refrigerant cylinders are no longer color-coded. R-454B cylinders are light green gray in color with a red band on the shoulder or top of the cylinder to indicate flammability.
- R-454B is only compatible with POE oils.
- Vacuum pumps will not remove moisture from POE oil used in R-454B systems.
- R-454B systems should be charged with liquid refrigerant in liquid phase. R-454B cylinders should be inverted to ensure liquid charging of the equipment.
- Do not install a suction line filter drier in the liquid line.
- A factory-approved outdoor liquid line filter drier is shipped with every unit and must be installed in the liquid line at the time of installation. If only the air-handler is being replaced on an existing system, the existing filter drier must be replaced at the time of installation with a field supplied filter drier. **IMPORTANT:** A bi-flow filter drier must be used for heat pump applications. Filter driers must be rated for minimum working pressure of 600 psig. The filter drier will only have adequate moisture-holding capacity if the system is properly evacuated.
- Desiccant (drying agent) must be compatible for POE oils and R-454B refrigerant.
- R-454B cylinders containing less than 50 lbs of refrigerant require a CGA 164 fitting. R-454B cylinders containing more than 50 lbs of refrigerant require a CGA 670 fitting.

3.2 APPLICATIONS

- Vertical Up-flow is the factory configuration for all models (see Figure 3).
- If return air is to be ducted, install duct flush with floor. Use fireproof resilient gasket 1/8 to 1/4 in. thick between duct, unit and floor. Set unit on floor over opening.

3.2.1 MOUNTING OPTIONS

The air handler comes standard with two different options for mounting, wall mount or frame mount. Both mounting options require the unit to be level from side to side and from front to back in order to allow condensate to properly drain from the unit. Failure to do this will result in condensate to leak out from the unit potentially causing structural damage to the surrounding support structures, dry wall, carpet, etc. around the unit. Also, both mounting structures require the ability to accommodate a minimum of 150 lb. load. Failure to do this will cause damage to the support structure and potentially damage the unit.

3.2.1.1 WALL MOUNT

The air handler comes standard with a wall mounting bracket and air handler mounting bracket. Reference Figure 5 for more detail.

1. Remove the wall mounting bracket from the back of the unit by removing one screw which attaches the bracket to the air handler. **NOTE:** Discard the screw after you have removed the wall mounting bracket.
2. Install bracket on the wall by using 6 wood screws (not provided). Make sure the bracket is level in order to provide proper drainage from the unit. **NOTE:** Do not attach the wall mounting bracket into unsupported dry wall. Make sure that the wood screws are going into a structure that can support a minimum of 150 lb load.
3. Lift the air handler above the wall mounting bracket and attached the unit to the installed bracket. Reference Figure 5.

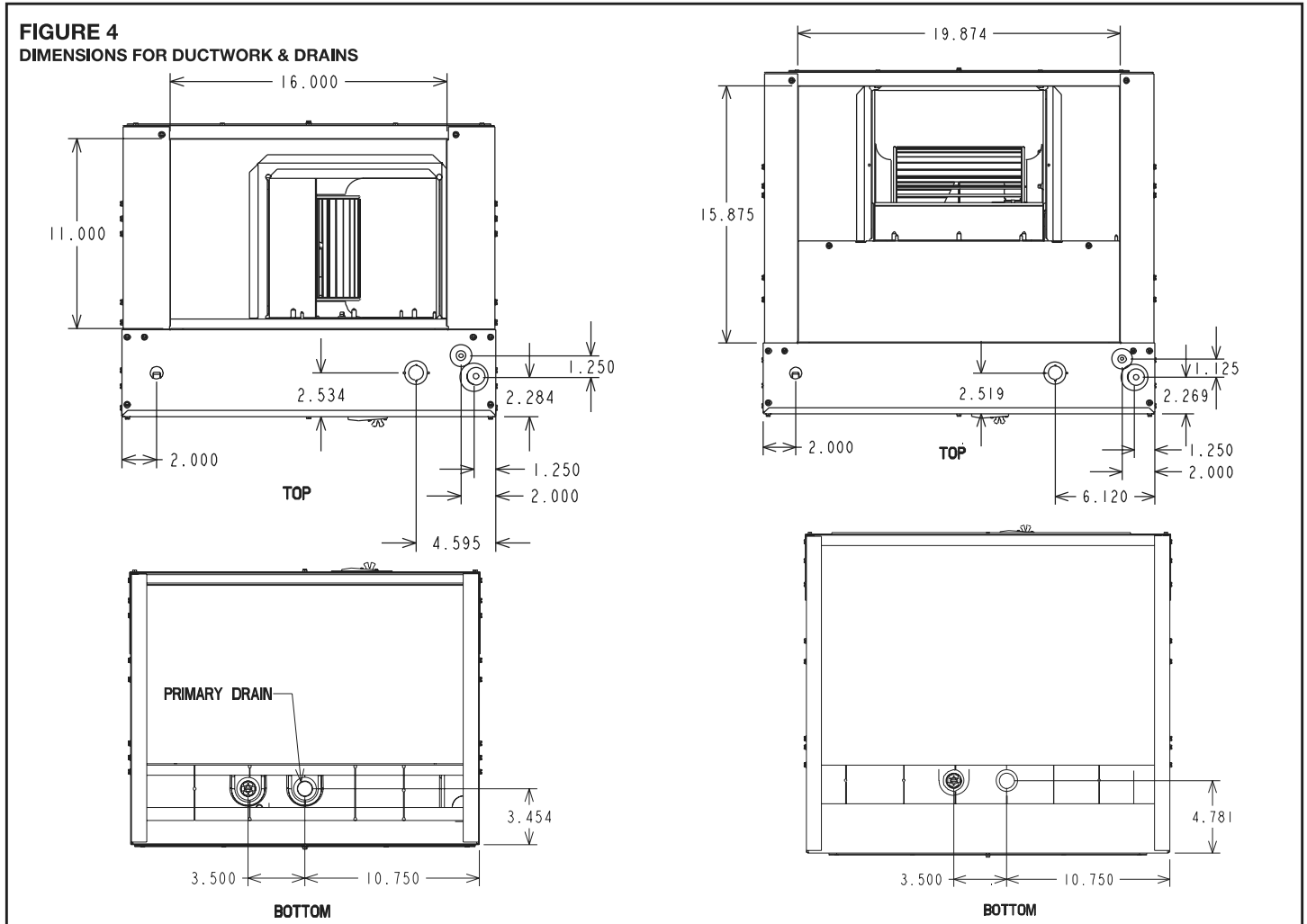

3.2.1.2 FRAME MOUNT

The air handler comes with 8 clearance holes 4 on each side. These holes are used to mount the air handler inside of a frame structure (see Figure 6). When mounting in this fashion, make sure that the wood screws are mounted from within the air handler and not outside of the unit. Installing the screws from the outside could cause damage to the coil.

3.2.1.3 FRONT RETURN AIR

Most applications for this style of air-handler bring the return air through into the front of the unit from the conditioned space with no return duct. The unit is shipped from the factory to accommodate this type of installation with no modifications. Louvered cabinet grilles and decorative wall grilles are available as an accessory to facilitate front return installations. (See Sections 6.4 and 6.5)

3.2.1.4 BOTTOM RETURN AIR

Should the application require the return air to enter the unit from the bottom, the unit can be easily converted to bottom return using an accessory kit (RXHK series) found in Section 6.3 of this manual. The conversion involves removing the block-off plate shipped installed in the bottom of the unit and installing the front door that comes with the conversion kit. Once converted, the unit can be mounted on a bottom return air platform or connected to a bottom return duct. If an external filter rack is installed, the unit's internal filter must be removed.

3.2.2 R-22 AIR-HANDLER REPLACEMENTS

(-)F1PY models can be used to replace an air-handler in applications using R-22 refrigerant with a simple orifice (piston) change. Refer to Section 3.8 for recommended orifice sizes for R-22 systems.

3.2.3 INSTALLATION IN AN UNCONDITIONED SPACE

The exterior cabinet of an air handler has a greater risk of sweating when installed in an unconditioned space than when it is installed in the conditioned space. This is primarily due to the temperature of the conditioned air moving through the air handler and the air circulating around the unit where it is installed. For this reason, the following is recommended for all air handler applications, but special attention should be paid to those installed in unconditioned spaces:

- Duct sizing and air-flow are critical and must be based on the equipment selected.
- Supply and return duct attachment: If other than the factory flanges are used, the attachment of ducting must be insulated and tight to prevent sweating.
- No perimeter supply flanges are provided. If a full perimeter supply duct is used, it is the responsibility of the installer to provide duct flanges as needed, to secure and seal the supply duct to prevent air leakage and the sweating that will result.
- Apply caulking around all cabinet penetrations such as power wires, control wires, refrigerant tubing and condensate line where they enter the cabinet. Seal the power wires on the inside where they exit conduit opening. Sealing is required to prevent air leakage into the unit which can result in condensate forming inside the unit, control box, and on electrical controls. Take care not to damage, remove or compress insulation when applying the caulk.
- In some cases, the entire air handler can be wrapped with insulation. This can be done as long as the unit is completely enclosed in insulation, sealed and service access is provided to prevent accumulation of moisture inside the insulation wrap.
- An auxiliary overflow pan is recommended to protect the structure from excessive cabinet sweating or a restricted coil drain line. (See Section 3.3)
- If an electric heater kit is installed, be sure the breaker or disconnect cover is sealed tightly to the door panel.

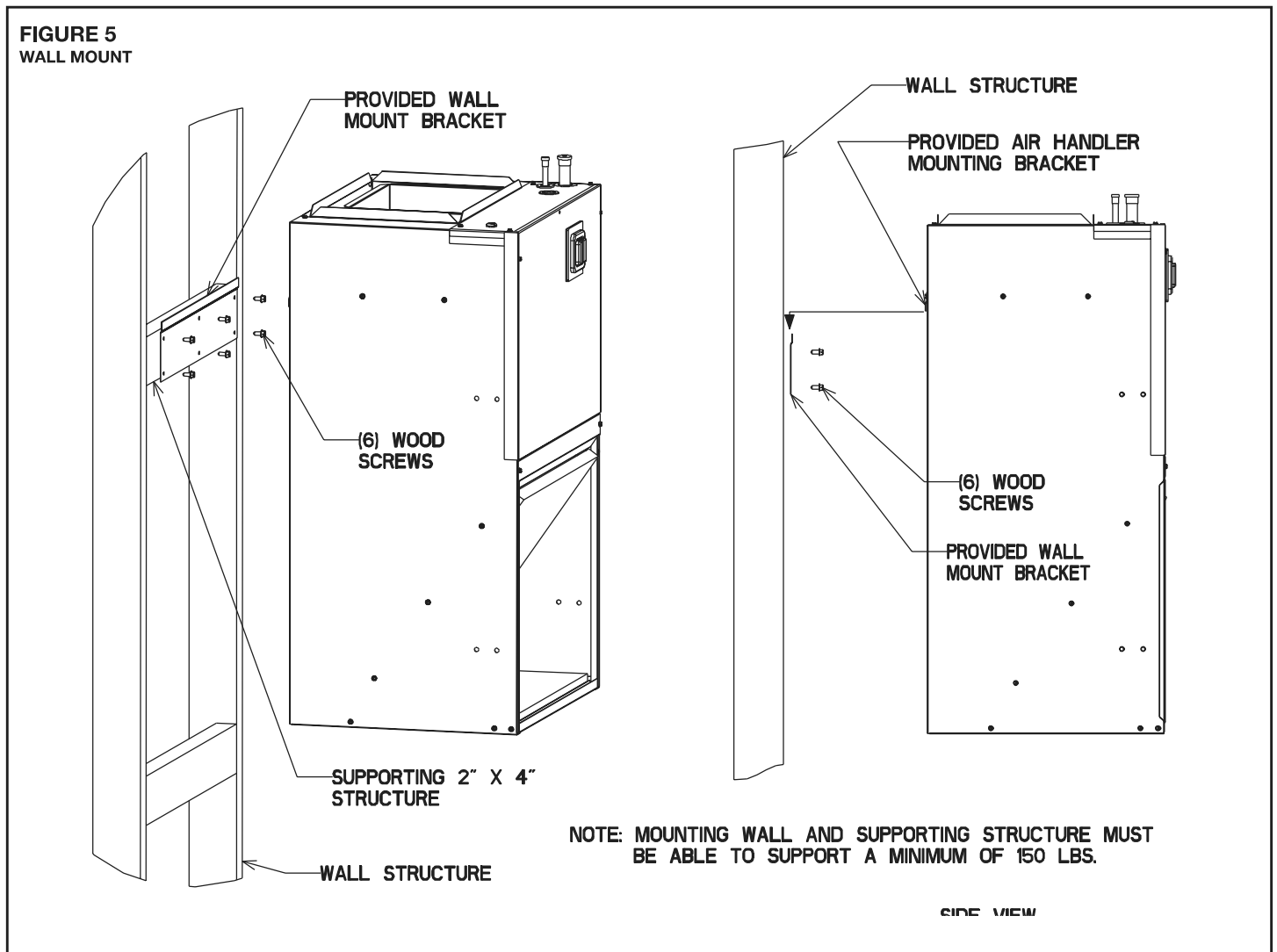

FRESH AIR OPENINGS

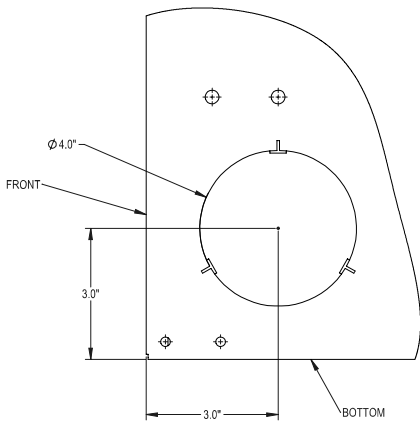

ST-A1344-01-00

3.2.4 INSTALLATION IN UNVENTILATED AREAS

If the installation room areas are not compliant with the outdoor room area values. Appliance shall not be installed in an area where there are potential ignition sources or a continuous open flame unless there is a flame arrest installed on flame-producing appliance.

Auxiliary devices which may be a potential ignition source shall not be installed in the duct work. Examples of such potential ignition sources are hot surfaces with a temperature exceeding 700°C (1292°F) and electric switching devices.

Only auxiliary devices that are approved by the manufacturer or declared suitable with the refrigerant can be installed in the connecting ductwork.

For appliances using A2L refrigerants, connected via an air duct system to one or more rooms, the supply and return air shall be directly ducted to the space. Open areas such as false ceilings shall not be used as a return air duct.

NOTE: "Unventilated" is defined by applications without an air circulation fan, or applications that do not employ a refrigerant detection system (RDS). For ventilation and room area table refer to RDS determination table in section 3.8.8 Refrigeration Detection System (RDS) Installation Instructions.

3.2.5 INSTALLATION IN CORROSIVE ENVIRONMENTS

The metal parts of this unit may be subject to rust or deterioration if exposed to a corrosive environment which can shorten its life. In addition to exposure to the exterior of the cabinet, chemical contaminants inside the building that can be drawn into the unit from the return air grille and attack structural metal parts, electrical components and the indoor coil, causing premature failure of the unit. If the unit is to be installed in an area where contaminants are likely to be a problem, special attention should be given to isolate the unit and return grille from contaminants.

FIGURE 6
FRAME MOUNT

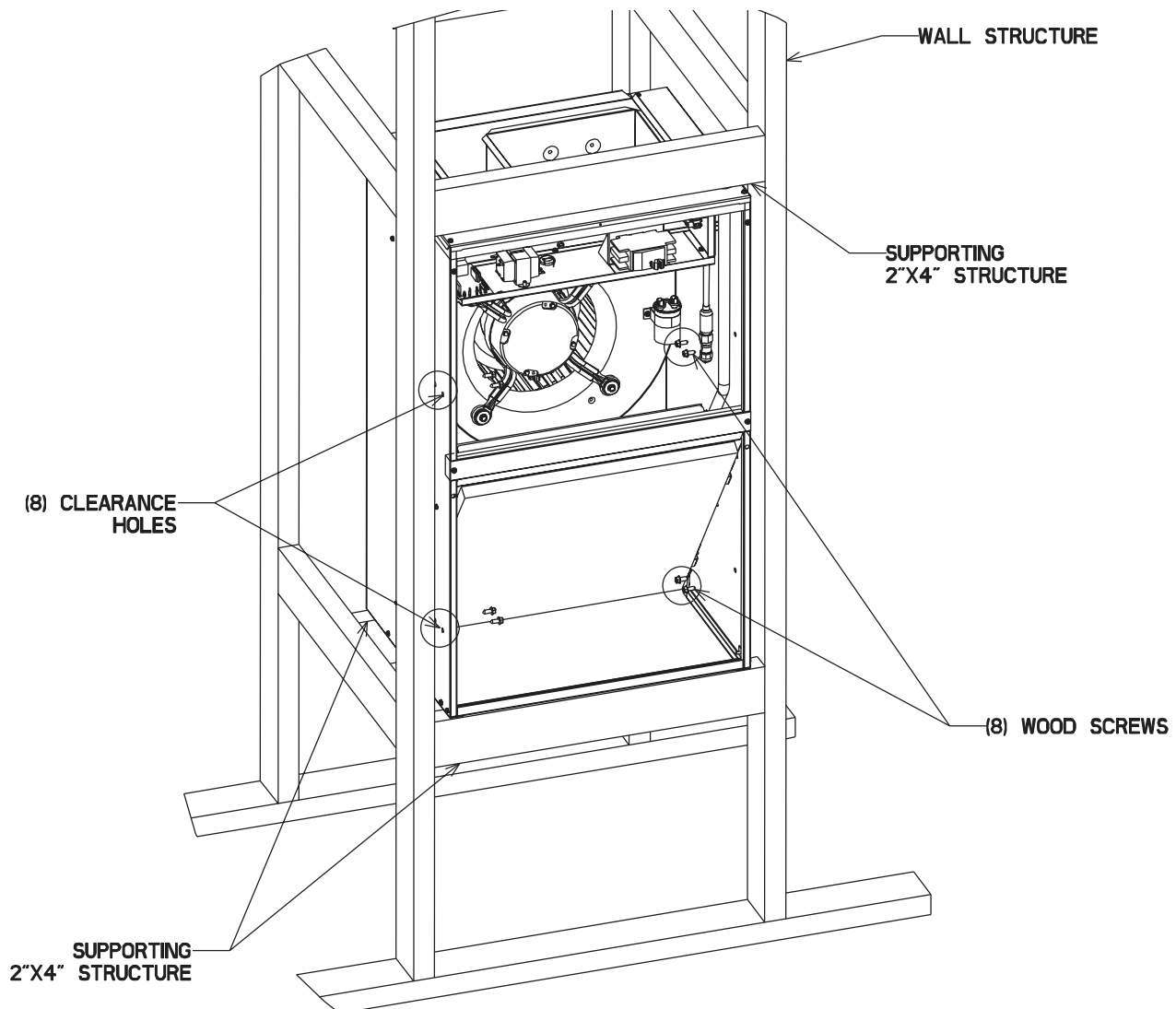

3.3 AUXILIARY OVERFLOW PAN

To comply with building codes, an auxiliary overflow pan must be installed under all equipment containing evaporator coils that are located in any area of a structure where damage to the building or building contents may occur as a result of an overflow of the coil drainpan or a stoppage in the primary condensate drain piping. Aftermarket overflow pans are available or one can be fabricated in the field as required.

3.4 DRAIN PAN OVERFLOW SWITCH

An overflow switch is available as a factory option (option code 417) or a field installed accessory kit (RXHK-A01- See Section 6.2) that will shut the outdoor unit off to prevent the water level in the unit drainpan from rising above a safe level. As with the auxiliary overflow pan, most building codes require a drain overflow switch for installations where structure damage can occur as a result of an overflow of the unit condensate drainpan.

3.5 CLEARANCES

- All units are designed for “0” inches clearance to combustible material on all cabinet surfaces.
- Units with electric heat require a one inch clearance to combustible material for the first three feet of supply plenum and ductwork.
- All units require 24 inches minimum access to the front of the unit for service.
- These units may be installed in either ventilated or non-ventilated spaces.

3.6 DUCTWORK

Field ductwork must comply with the National Fire Protection Association NFPA 90A, NFPA 90B and any applicable local ordinance.

 WARNING
Do not, under any circumstances, connect return ductwork to any other heat producing device such as fireplace insert, stove, etc. Unauthorized use of such devices may result in fire, carbon monoxide poisoning, explosion, personal injury or property damage.

Sheet metal ductwork run in unconditioned spaces must be insulated and covered with a vapor barrier. Fibrous ductwork may be used if constructed and installed in accordance with SMACNA Construction Standard on Fibrous Glass Ducts. Ductwork must comply with National Fire Protection Association as tested by U/L Standard 181 for Class I Air Ducts. Check local codes for requirements on ductwork and insulation.

- Duct system must be designed within the range of external static pressure the unit is designed to operate against. It is important that the system air-flow be adequate. Make sure supply and return ductwork, grilles, special filters, accessories, etc. are accounted for in total resistance. See air-flow performance tables in this manual.
- Design the duct system in accordance with “ACCA” Manual “D” Design for Residential Winter and Summer Air Conditioning and Equipment Selection. Latest editions are available from: “ACCA” Air Conditioning Contractors of America, 1513 16th Street, N.W., Washington, D.C. 20036. If duct system incorporates **flexible air duct**, be sure **pressure drop** information (straight length plus all turns) shown in “ACCA” Manual “D” is accounted for in system.
- Supply plenum is attached to the 3/4” duct flanges supplied with the unit. Attach flanges around the blower outlet.

IMPORTANT: If an elbow is included in the plenum close to the unit, it must not be smaller than the dimensions of the supply duct flange on the unit.

IMPORTANT: The front flange on the return duct if connected to the blower casing must not be screwed into the area where the power wiring is located. Drills or sharp screw points can damage insulation on wires located inside unit.

- Secure the supply and return ductwork to the unit flanges, using proper fasteners for the type of duct used and tape the duct-to-unit joint as required to prevent air leaks.

3.7 RETURN AIR FILTER

An internal filter rack is provided with this unit and is sufficient for most applications using this type of air-handler. If an external means of filtering the return air is required, the external filters should be sized for a maximum of 300 feet/min air velocity or the maximum velocity recommended by the type of filter installed. One or more return air filter grilles, a filter rack attached to unit return air intake, or a filter rack installed between a sealed return air platform and the return duct are all acceptable means of filtration. All return ducts must be filtered, either at each return grille or at a common filter near or inside the unit.

IMPORTANT: Do not install a return air filter grille if a filter rack is installed at the unit or the internal filter is used. Do not install a filter in the supply duct system.

Filter type, sizing, and placement are critical to heating and cooling system performance. Reduced air-flow can shorten the life of system components such as the compressor, indoor coil, heater elements, over temperature limits, and relays. As filters near the end of their useful life, the pressure drop through them increases. Therefore, it is important to factor the “end of life” (dirty) pressure drop filters the external static pressure of the duct system when selecting blower speeds and designing ductwork to assure the system is operating at the design CFM and system reliability is not compromised. Always verify that the system’s air-flow is within specifications by performing a temperature rise (heating mode) and temperature drop (cooling mode) with all filters in place.

IMPORTANT: High efficiency pleated filters and electronic air cleaners typically have significantly higher pressure drop than standard efficiency fiberglass filters, especially when they get dirty. Do not use high efficiency filters or electronic air cleaners unless adequate filter area is provided to lower the filter pressure drop to an acceptable level.

CAUTION

R-454B is classified as safety group A2L per ASHRAE Standard 34. Verify that service equipment and instruments are approved for use with group A2L refrigerants, and in particular with R-454B. Failure to exercise care may result in equipment damage or personal injury.

3.8 REFRIGERANT LINE CONNECTIONS & CHARGING

Pipe-work including piping material, pipe routing, and installation shall include protection from physical damage in operation and service, and be in compliance with national and local codes and standards, such as ASHRAE 15, ASHRAE 15.2, IAPMO Uniform Mechanical Code, ICC International Mechanical Code, or CSA B52. All field joints shall be accessible for inspection prior to being covered or enclosed.

After completion of field piping for split systems, the field pipework shall be pressure tested with an inert gas and then vacuum tested prior to refrigerant charging, according to the following requirements:

- The minimum test pressure for the low side of the system shall be the low side design pressure and the minimum test pressure for the high side of the system shall be the high side design pressure, unless the high side of the system, cannot be isolated from the low side of the system in which case the entire system shall be pressure tested to the low side design pressure.
- Field-made refrigerant joints indoors shall be tightness tested. The test method shall have a sensitivity of 5 grams per year of refrigerant or better under a pressure of at least 0,25 times the maximum allowable pressure.
- No leak shall be detected; where addition of charge is required to complete installation, refer to the Outdoor I/O System start-up and refrigerant charging details for instructions on how to determine the additional REFRIGERANT CHARGE and how to complete the REFRIGERANT CHARGE on the label provided by the manufacturer. Interconnecting refrigerant piping length and diameter shall be taken into consideration as listed in the Line Set Selection.

3.8.1 PREPARATION

The coil is shipped with a low pressure (5-10 psig) charge of dry nitrogen which will be released when the rubber plugs are removed. Leave the rubber plugs in the refrigerant connection stubs on the air-handler until the refrigerant lines are ready to be brazed to the refrigerant connection stubs to prevent contaminants from entering the coil. Clean the ends of the tubing and coil connection stubs (inside and outside) with an alcohol wipe before inserting the line set tubes into the coil connection stubs to assure a quality leak-free braze joint.

Refer to the outdoor unit installation instructions for details on refrigerant line sizing and installation. Be sure to follow long line length guidelines if they apply.

Route the refrigerant tubing in a manner than does not block service access to the front of the air-handler.

3.8.2 LIQUID LINE FILTER DRIER

A new liquid filter drier must be installed every time any part of the system has been open to the atmosphere, even if it's for a short period of time. The filter drier should be installed close to the air-handler for a system started up in the cooling mode and near the outdoor unit for a heat pump system started up in the heating mode. This allows the filter drier to catch any contaminants in the liquid line before they can enter the indoor or outdoor TXV or piston inlet screen.

3.8.3 BRAZING

Air inside the tubing and coil should be displaced with dry nitrogen prior to the brazing process to prevent the formation of harmful copper oxide inside the tubing. It is very important not to pressurize the system with nitrogen while brazing or pin-hole leaks will form in the braze joint. This is accomplished by removing the gauge port valve core on one of the outdoor unit service valves to allow the pressure to be relieved as the heated nitrogen expands. Fill the system with dry nitrogen through the other service valve gauge port and then turn the nitrogen flow off just before brazing is begun.

Protect the TXV, copper to aluminum suction header joint, and outdoor unit service valves from overheating using a wet rag or heat sink compound. Leave the wet rag or heat sink material in place until the joint and surrounding tubing cools down to a safe temperature. Double tip torches can help minimize brazing time and heat conduction to the heat sensitive components if the flame is turned down and held on the joint just long enough to make the braze joint. With both single and double tip torches, turning the flame up too much and keeping the flame on the joint too long will damage the heat sensitive components even when a wet rag or heat sink compound is used.

Use a sheet metal shield to protect the cabinet's finish from the torch flames during the brazing process. The vapor line insulation should be pushed back on the line about 12 inches from the joint and retained to prevent it from igniting or melting during the brazing process.

After the refrigerant brazed connections are made at the air-handler and the tubing has cooled down sufficiently, seal the air gap around the connection stubs with the foam rubber gasket included in the air-handler parts bag. Peel the self-adhesive backing off of the foam gasket and position it around the stubs with the adhesive side toward the cabinet, then press it firmly against the cabinet. The gasket is split to allow it to go over the stubs after the refrigerant tubes are brazed to the stubs.

After the foam gasket has been installed, the vapor line insulation should be pulled back in place so it contacts the air-handler cabinet to prevent condensate from forming on the cold tube and dripping off. A loosely fitting zip-tie placed around the insulation ½" from the end can be used to hold it in place so it doesn't move away from the cabinet.

3.8.4 LEAK TESTING

After all braze joints are completed, replace the valve core removed when purging with nitrogen and then leak test the system by pressurizing to 150 psig with dry nitrogen and allow the system to sit for at least 15 minutes (longer if possible) to assure the pressure does not drop.

3.8.5 EVACUATION

If no leaks are detected, evacuate the system down to 500 microns or below before charging the system or opening the service valves on the outdoor unit which will release the charge stored in the outdoor unit into the line set and air-handler coil. Failure to reach 500 microns of vacuum is a sign of a leak or excessive moisture inside the system.

3.8.6 REFRIGERANT CHARGING

Once the evacuation process is completed, break the vacuum with the refrigerant from a refrigerant cylinder or with refrigerant stored in the outdoor unit by opening the outdoor unit service valves. The charging process cannot be completed until the remaining steps in the installation process are completed and the indoor air-flow is adjusted to the proper level. See Section 4.7 for further details.

3.8.7 REFRIGERANT DETECTION SYSTEM (RDS)

The RDS is used to mitigate any leaked refrigerant that may occur in the indoor portion of the system.

Life expectancy of the RDS is 15 years and should be replaced at the end of life.

Contact Rheem Parts Department for RDS replacement.

Tripped RDS Sequence of Operations:

Step 1: RDS detects a leak at or over the sensor setpoint.

Step 2: Relay in RDS shuts ODU down and energizes the indoor blower.

Step 3: Leaked refrigerant gets dispersed during the blower on cycle.

Step 4: Once the concentration of the leaked refrigerant is below the RDS setpoint, the blower continues to run for 5 minutes.

Step 5: If the concentration stays below the RDS setpoint for 5 minutes, the system returns to normal operation.

NOTE: There is no lockout timer, and the system can continue to go through these steps.

3.8.8 REFRIGERANT DETECTION SYSTEM (RDS) INSTALLATION AND MAINTENANCE

Ensure sensor is free of dust and debris to ensure proper function of the RDS.

Sensor bracket is secured to the bracket by a single screw and must be removed to wipe off and dust or debris from the face of the sensor.

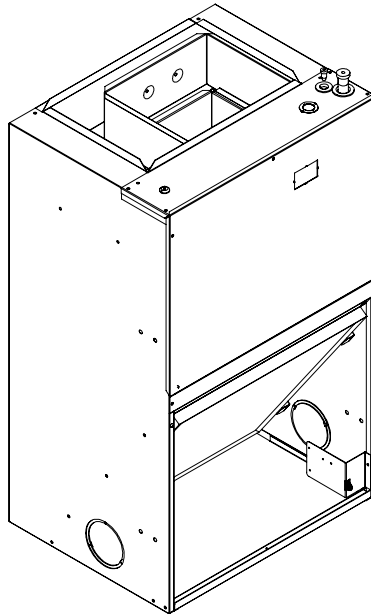

RDS DETERMINATION TABLE

Total System Charge (oz)	Minimum Indoor Airflow (CFM)	Without Refrigerant Leak Detection Sensor Area of Smallest Conditioned Room Or Space Where Indoor Unit is Installed (sqft)			With Refrigerant Leak Detection Sensor Minimum Required Total Conditioned Room Area = Sum of all conditioned spaces/rooms (sqft) Any configuration
		Distance From Floor to Bottom Edge of Lowest Inlet or Outlet Vent Opening or Bottom Edge of Indoor Unit			
		≤2 FT	6 FT	≥9 FT	
50	166	338	113	75	94
100	333	781	225	150	187
150	499	1758	338	225	281
200	665	3126	451	301	375
250	831	4884	564	376	469
300	998	7032	781	451	562
350	1164	9572	1064	526	656
400	1330	12502	1389	617	750
450	1497	15823	1758	781	843
500	1663	19534	2170	965	937
550	1829	not permitted - sensor required			1031
600	1996				1125

NOTE: If the total charge quantity falls between two rows, use the minimum room area and airflow in the row corresponding to the higher total system charge.

3.9 CONDENSATE DRAIN

Consult local codes or ordinances for specific requirements.

IMPORTANT: When making drain fitting connections to the drain pan, use a thin layer of Teflon paste, silicone or Teflon tape and install hand tight.

IMPORTANT: When making drain fitting connections to drain pan, do not over tighten. Over tightening fittings can split pipe connections on the drain pan.

- Install drain lines so they do not block service access to front of the unit. Minimum clearance of 24 inches is required for filter, coil or blower removal and service access.
- Although the condensate drain pan is designed to be self draining, it is recommended that the air-handler cabinet be pitched slightly downward toward the primary drain connection to assure the condensate drains completely from the drain pan. The downward pitch should be approximately 1/8" per foot and in both axes.
- Do not reduce drain line size less than connection size provided on condensate drain pan.
- All drain lines must be pitched downward away from the unit a minimum of 1/8" per foot of line to ensure proper drainage.
- Do not connect condensate drain line to a closed or open sewer pipe. Run condensate to an open drain or outdoors.
- The drain line should be insulated where necessary to prevent sweating and damage due to condensate forming on the outside surface of the line.

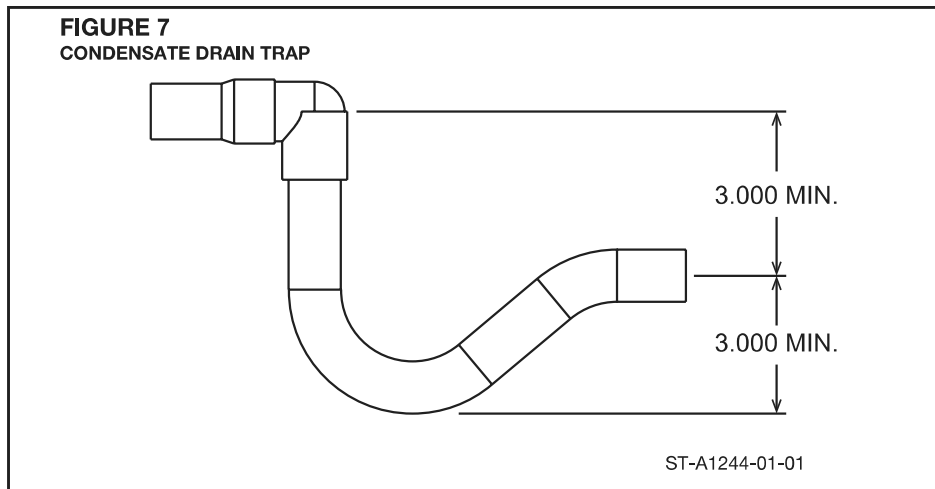

- Make provisions for disconnecting and cleaning of the primary drain line should it become necessary. Install a 3 in. trap in the primary drain line as close to the unit as possible. Make sure that the top of the trap is below connection to the drain pan to allow complete drainage of pan (See Figure 7).
- The auxiliary drain line should be run to a place where it will be noticeable if it becomes operational. The building occupant should be warned that a problem exists if water should begin running from the auxiliary drain line. An auxiliary drain shut-off switch can be installed in lieu of an auxiliary drain line. The shut-off switch should be wired into the control circuit so the outdoor unit shuts down should the switch detect water.
- Plug the unused drain connection with the plugs provided in the parts bag, using a thin layer of Teflon paste, silicone or Teflon tape to form a water tight seal.
- Test the condensate drain pan and drain line after installation is complete. Pour water into drain pan, enough to fill drain trap and line. Check to make sure drain pan is draining completely, no leaks are found in drain line fittings, and water is draining from the open end of the primary drain line.

3.10 THERMOSTAT

See instructions for the condensing unit or heat pump for recommended room thermostats.

- On units with one electric heat sequencer (TD₁) (see wiring diagram for electric heater), heat anticipator setting should be .16.
- On units with two electric heat sequencers (TD₁ & TD₂) (see wiring diagram for electric heater), heat anticipator setting should be .32 if both are connected to same stage on thermostat. Setting should be .16 if (TD₁ & TD₂) are connected to separate stages.

NOTE: Some thermostats contain a fixed, non-adjustable heat anticipator. Adjustment is not permitted.

- The thermostat should be mounted 4 to 5 feet above the floor on an inside wall of the living room or a hallway that has good air circulation from the other rooms being controlled by the thermostat. It is essential that there be free air circulation at the location of the same average temperature as other rooms being controlled. Movement of air should not be obstructed by furniture, doors, draperies, etc. The thermostat should not be mounted where it will be affected by drafts, hot or cold water pipes or air ducts in walls, radiant heat from fireplace, lamps, the sun, T.V. or an outside wall. See instruction sheet packaged with thermostat for mounting and installation instructions.

3.11 ELECTRICAL WIRING

Field wiring must comply with the National Electric Code (C.E.C. in Canada) and any applicable local ordinance.

 WARNING
Disconnect all power to unit before installing or servicing. More than one disconnect switch may be required to de-energize the equipment. Hazardous voltage can cause severe personal injury or death.

3.11.1 CONFIGURING UNIT FOR 208 VOLT POWER

The control transformer in 208/240V air-handlers must be configured in the field to operate on a 208 volt electrical supply to assure adequate control voltage (24+ volts) with the reduced supply voltage. The units are shipped from the factory for 230-240 volt applications. For 208 volt applications, disconnect electrical power to the unit and remove the blower/control access panel on the front of the unit. Then remove the insulated cap from the 208 volt transformer terminal and move the BLACK wires that are connected to the 240 volt transformer terminal to the 208 volt transformer terminal. Plug the insulated cap onto the transformer 240V terminal. The PSC indoor blower motor in the (-)F1P air-handlers must also be configured for 208 volt applications to assure full air-flow delivery at the reduced voltage.

This step is not required on (-)F1T air-handlers since they have constant torque ECM motors. To configure the PSC motor in (-)F1P air-handlers for 208 volt applications, unplug the PURPLE motor lead connected to the insulated terminal on the end of the ORANGE wire coming from the transformer. Pull the cap out of the insulated terminal on end of the YELLOW motor lead and plug the cap into the terminal on the end of the PURPLE motor lead to eliminate the possibility of an electrical short. Plug the YELLOW motor lead into the terminal on the end of the ORANGE wire from the transformer. Secure the indoor blower motor wiring with zip ties to assure they can't come in contact with the blower wheel.

Replace the blower/control box access panel when the above is complete before applying electrical power to the unit.

3.11.2 GROUNDING

- Grounding may be accomplished by grounding metal conduit when installed in accordance with electrical codes to the unit cabinet.

 WARNING
The unit must be permanently grounded. Failure to do so can result in electrical shock causing personal injury or death.

- Grounding may also be accomplished by attaching ground wire(s) to ground lug(s) provided in the unit wiring compartment.
- Ground lug(s) are located close to wire entrance on left side of unit.
- Use of multiple supply circuits require grounding of each circuit to lug(s) provided in unit.

3.11.3 POWER WIRING

It is important that proper electrical power is available for connection to the unit model being installed. See the unit nameplate, wiring diagram and electrical data in the installation instructions.

- If required, install a branch circuit disconnect of adequate size, located within sight of, and readily accessible to the unit.

IMPORTANT: Units with electric heater kits installed may be equipped with one, two, or three 30/60 amp circuit breakers. These breaker(s) protect the internal wiring in the event of a short circuit and serve as a disconnect. Circuit breakers installed within the unit do not provide over-current protection of the supply wiring and therefore may be sized larger than the branch circuit protection.

- Supply circuit power wiring must be 75°C minimum copper conductors only. See Electrical Data in Sections 3.12.5 and 3.12.6 for ampacity, wire size and circuit protector requirement. Supply circuit protective devices may be either fuses or “HACR” type circuit breakers.
- Field power wiring may be connected to either the right, left side or top. Three 7/8”, 1³/₃₂”, 1³¹/₃₂” dia. concentric knockouts are provided for connection of power wiring to unit.
- Field power wiring is to be connected to the power terminal block in unit control compartment.
- For units equipped with an electric heater kit, field power wiring is to be connected to the heater kit breaker, terminal block, or pullout disconnect terminals and the power wiring pigtail from the heater kit is to be connected to the unit power terminal block in the unit control compartment. Refer to installation instructions provided with the heater kit for additional details.

3.11.4 COPPER WIRE SIZE - AWG. (3% VOLTAGE DROP)

S U P P L Y	L E N G T H	200 [61]	12	10	8	8	8	6	6	6	4	4	3	3	2	2	1	0	00	
		150 [46]	12	10	10	10	8	8	6	6	6	4	4	3	3	3	2	1	0	00
		100 [30]	14	12	10	10	8	8	8	6	6	4	4	3	3	3	2	1	0	00
		50 [15]	14	12	10	10	8	8	8	6	6	4	4	3	3	3	2	1	0	00
			15	20	25	30	35	40	45	50	60	70	80	90	100	110	125	150	175	
W I R E	F E E T	SUPPLY CIRCUIT AMPACITY																		
		NOTE: WIRE BASED ON COPPER CONDUCTORS 75°C MINIMUM RATING. FOR MORE THAN 3 CONDUCTORS IN A RACEWAY OR CABLE, SEE N.E.C. FOR DERATING THE AMPACITY OF EACH CONDUCTOR.																		

3.11.5 RF1PY/RF2TY ELECTRICAL DATA - BLOWER MOTOR ONLY - NO ELECTRIC HEAT

Model/Nominal Cooling Tons	Voltage	Phase	Hertz	HP [W]	RPM	Speeds	Circuit Amps.	Minimum Circuit Ampacity	Maximum Circuit Protector
RF1PY1821	208/240	1	60	1/5 [149]	1075	2	1.9	3	15
RF1PY2421	208/240	1	60	1/4 [149]	1075	2	1.9	3	15
RF1PY3024	208/240	1	60	1/3 [249]	1075	2	2.7	4	15
RF1PY3624	208/240	1	60	1/2 [373]	1075	2	2.7	4	15
RF2TY2421	208/240	1	60	1/3 [249]	300-1100	4	1.9	3	15
RF2TY3624	208/240	1	60	1/2 [373]	300-1100	4	2.7	4	15

3.11.6 RF1PY/RF2TY ELECTRICAL DATA - WITH ELECTRIC HEAT

Installation of the UL Listed original equipment manufacturer provided heater kits listed in the following table is recommended for all auxiliary heating requirements.

Cooling Capacity Tons	Model No.	Heater kW	PH/Hz	No. Elements - kW Per	(208/240V) Type Supply Circuit	Circuit Amps.	Motor Ampacity	Minimum Circuit Ampacity	Maximum Circuit Protection
RF1PY 18	RXHJ-21B/T03J-1	2.25/3.0	1/60	1-3.0	Single	10.8/12.5	1.9	16/18	20/20
	RXHJ-21B/T05J-1	3.6/4.8	1/60	1-4.8	Single	17.3/20.0	1.9	24/28	25/30
	RXHJ-21B/T08J-1	5.4/7.2	1/60	2-3.6	Single	26.0/30.0	1.9	35/40	35/40
RF1PY 24	RXHJ-21B/T03J-1	2.25/3.0	1/60	1-3.0	Single	10.8/12.5	1.9	16/18	20/20
	RXHJ-21B/T05J-1	3.6/4.8	1/60	1-4.8	Single	17.3/20.0	1.9	24/28	25/30
	RXHJ-21B/T08J-1	5.4/7.2	1/60	2-3.6	Single	26.0/30.0	1.9	35/40	35/40
	RXHJ-21B/T10J-1	7.2/9.6	1/60	2-4.8	Single	34.6/40.0	1.9	46/53	50/60
RF1PY 30	RXHJ-24B/T03J-1	2.25/3.0	1/60	1-3.0	Single	10.8/12.5	2.7	17/19	20/20
	RXHJ-24B/T05J-1	3.6/4.8	1/60	1-4.8	Single	17.3/20.0	2.7	25/29	25/30
	RXHJ-24B/T08J-1	5.4/7.2	1/60	2-3.6	Single	26.0/30.0	2.7	36/41	40/45
	RXHJ-24B/T10J-1	7.2/9.6	1/60	2-4.8	Single	34.6/40.0	2.7	47/54	50/60
RF1PY 36	RXHJ-24B/T03J-1	2.25/3.0	1/60	1-3.0	Single	10.8/12.5	2.7	17/19	20/20
	RXHJ-24B/T05J-1	3.6/4.8	1/60	1-4.8	Single	17.3/20.0	2.7	25/29	25/30
	RXHJ-24B/T08J-1	5.4/7.2	1/60	2-3.6	Single	26.0/30.0	2.7	36/41	40/45
	RXHJ-24B/T10J-1	7.2/9.6	1/60	2-4.8	Single	34.6/40.0	2.7	47/54	50/60
RF2TY 24	RXHJ-21B/T03J-1	2.25/3.0	1/60	1-3.0	Single	10.8/12.5	1.9	16/18	20/20
	RXHJ-21B/T05J-1	3.6/4.8	1/60	1-4.8	Single	17.3/20.0	1.9	24/28	25/30
	RXHJ-21B/T08J-1	5.4/7.2	1/60	2-3.6	Single	26.0/30.0	1.9	35/40	40/40
	RXHJ-21B/T10J-1	7.2/9.6	1/60	2-4.8	Single	34.6/40.0	1.9	46/53	50/60
RF2TY 36	RXHJ-24B/T03J-1	2.25/3.0	1/60	1-3.0	Single	10.8/12.5	2.7	17/19	20/20
	RXHJ-24B/T05J-1	3.6/4.8	1/60	1-4.8	Single	17.3/20.0	2.7	25/29	25/30
	RXHJ-24B/T08J-1	5.4/7.2	1/60	2-3.6	Single	26.0/30.0	2.7	36/41	40/50
	RXHJ-24B/T10J-1	7.2/9.6	1/60	2-4.8	Single	34.6/40.0	2.7	47/54	50/60

NOTES:

- Electric heater BTUH - (heater watts + motor watts) x 3.412 (see air-flow table for motor watts.)
- Supply circuit protective devices may be fuses or "HACR" type circuit breakers.
- J Voltage (208/240V) single phase air handler is designed to be used with single or three phase 208/240 volt electric heaters. In the case of connecting 3 phase power to air handler terminal block without the heater, bring only two leads to terminal block, cap, insulate and fully secure the third lead.

3.11.7 ELECTRIC HEATER SUPPLEMENTAL INFORMATION

MFG DATE/FRQ: 12/2009 RHEEM SALES COMPANY, INC. ASSEMBLED IN THE U.S.A. AREUNI AUX STATS-UNES

MODEL/MODELE# RF1P2421STAN00 SERIAL/EN SERIES # F000900001
 VOLTS 208/240 PH/HZ 1 / 60 MOTOR HP/F.L.A. 1/5 / 1.5
 MOTEUR PSC/F.L.A.

ATTENTION: MARK HEATER KIT INSTALLED IN LEFT COLUMN/LA TROUSSE D'APPAREIL DE CHAUFFAGE DE MARQUE A INSTALLER DANS LA COLONNE GAUCHE

HEATER MODEL/MODELE D'APPAREIL DE CHAUFFAGE	TYPE SUPPLY CIRCUIT/TAPER LE CIRCUIT DE PROVISION	VOLTAGE/TENSION	PHASE	KW	HEATER AMPS/AMPLIS D'APPAREIL DE CHAUFFAGE	MOTOR AMPS/LES AMPLIS MOTEURS	MAXIMUM OVERCURRENT PROTECTION/ LA PROTECTION MAXIMUM DE OVERCURRENT	MINIMUM BRANCH CIRCUIT AMPACITY/ MINIMUM DE CIRCUIT DE BRANCHE
X NO HEAT				0		1.5	15	3.0
RXH21B03J	SINGLE	208/240	1/60	2.25/3.0	10.8/12.5	1.6	20/20	16/18
RXH21B05J	SINGLE	208/240	1/60	3.6/4.8	17.3/20.0	1.6	25/30	24/27
RXH21B08J	SINGLE	208/240	1/60	5.4/7.2	26.0/30.0	1.6	35/40	35/40
RXH21B10J	SINGLE	208/240	1/60	7.2/9.6	34.6/40.0	1.6	46/52	50/60

Only listed kits can be applied

S = SINGLE CIRCUIT/CIRCUIT SIMPLE M = MULTIPLE CIRCUIT/CIRCUIT MULTIPLE
 INDOOR BLOWER MOTOR LOAD INCLUDED IN CIRCUIT # 1 OR TOTAL SUPPLY WIRE MUST BE RATED AT 75°C MINIMUM COPPER CONDUCTORS ONLY TEST EXTERNAL STATIC RANGE .1 TO .5 IN. W.C. (HEAT PUMP & ELECTRIC HEAT).
 UNITS WITH ELECTRIC HEATERS: CLEARANCE TO COMBUSTIBLE MATERIAL TO BE 0 IN. TO UNIT CASING AND 0 IN. TO PLENUM AND DUCT FOR FIRST 36 IN. MODELS HAVE INTEGRAL CIRCUIT BREAKERS WHICH PROVIDE SUPPLEMENTARY OVER CURRENT PROTECTION AND SERVE AS A MAINTENANCE "DISCONNECT". SUPPLY CIRCUIT NOT TO EXCEED 120 VOLTS TO GROUND ON SINGLE PHASE UNITS. REPLACE LINE SIDE BREAKER COVER(S) AFTER MAKING WIRING CONNECTIONS TO BREAKER(S). IF BLOWER CONTROL ASSEMBLY REQUIRED REMOVAL, SEE "WARNING HAZARDOUS VOLTAGE".
 CHARGEMENT DU MOTEUR SOUFFLEUR INTERNE INCLUS DANS LE CIRCUIT # 1 OU CAPACITÉ D'ALIMENTATION TOTAL DOIT ÊTRE DE 75C DU MINIMUM DE CONDUCTEURS DE CUIVRE SEULEMENT. TESTER L'INTERVALLE STATIQUE EXTERNE : 1 À 5 PO W.C. (THERMOPOMPE ET CHAUFFAGE ÉLECTRIQUE)
 UNITÉS AVEC CHAUFFAGES ÉLECTRIQUES : LE DÉGAGEMENT AUX MATIÈRES COMBUSTIBLES DOIT ÊTRE DE 0 po AU BOITIER DE L'UNITÉ ET DE 0 po AU PLÉNUM ET CONDUIT POUR LES 36 PREMIERS po. LES MODÈLES DISPOSENT DE DISJONCTEURS INTÉGRÉS QUI FOURNISSENT UNE PROTECTION SUPPLÉMENTAIRE DE SURINTENSITÉ DE COURANT ET SERVENT DE « SECTIONNEUR » D'ENTRETIEN. LE CIRCUIT D'ALIMENTATION NE DOIT PAS DÉPASSER 120 VOLTS JUSQU'AU SOL SUR DES UNITÉS MONOPHASÉES. REMPLACER LE(S), COUVERCLE(S) DU DISJONCTEUR DU DISJONCTEUR DU CÔTÉ SECTEUR APRÈS AVOIR EFFECTUÉ LA CONNEXION DES CÂBLAGES AUX(X) DISJONCTEUR(S). SI L'ASSEMBLAGE DE CONTRÔLE DU VENTILATEUR A BESOIN D'ÊTRE DÉASSEMBLÉ, CONSULTER "AVERTISSEMENT DE TENSION DANGEREUSE"

Contractor should "mark or check" the left column for the kit installed.

These are the required maximum and minimum circuit breaker sizes for overcurrent protection and should not be confused with the size of the breakers installed in the heater kit.

Heater Kit Supplemental Information: What allows the manufacturer to use standard Circuit Breakers up to 60 amps inside the air handler, when using an approved Heater Kit?

National Electric Code (Section 424-22b) and our UL requirements allow us to subdivide heating element circuits, of less than 48 amps, using breakers of not more than 60 amps and, additionally by, NEC 424-3b, a rating not less than 125 percent of the load and NEC 424-22c, which describes the supplementary over current protection required to be factory-installed within, or on the heater. The breakers in the heater kit are not, and have never been, by NEC, intended to protect power wiring leading to the air handler unit. The breakers in the heating kit are for short circuit protection. All internal unit wiring, where the breakers apply, has been UL approved for short circuit protection.

Ampacity, (not breaker size), determines supply circuit wire size. The ampacity listed on the unit rating plate and the Maximum and Minimum circuit breaker size (noted above) or in the units specification sheet or installation instructions provides the information to properly select wire and circuit breaker/protector size. The National Electric Code (NEC) specifies that the supply or branch circuit must be protected at the source.

3.11.8 CONTROL WIRING

IMPORTANT: Class 2 low voltage control wire should not be run in conduit with power wiring and must be separated from power wiring, unless class 1 wire of proper voltage rating is used.

- Low voltage control wiring should be 18 Awg. color-coded. For lengths longer than 100 ft., 16 Awg. wire should be used.
- Low voltage control connections are made to low voltage pigtails extending from top of air handler. Connections for control wiring are made with wire nuts. Control wiring knockouts are also provided on the left side of the unit.
- See wiring diagrams attached to indoor and outdoor sections to be connected, or control wiring diagram booklet supplied with outdoor heat pump section for wiring connection.
- Make sure, after installation, separation of control wiring and power wiring has been maintained.

3.11.9 THERMOSTAT & CONTROL WIRING CONNECTIONS

NOTE: These low voltage application diagrams are generic. Your indoor/outdoor units may not have all the characteristics shown or may not wire exactly as shown. Refer to the diagrams and information sent with your indoor/outdoor sections.

WIRE COLOR CODE:

BK - BLACK	G - GREEN	P - PINK	W - WHITE
BR - BROWN	GY - GRAY	PR - PURPLE	Y - YELLOW
GL - BLUE	O - ORANGE	R - RED	

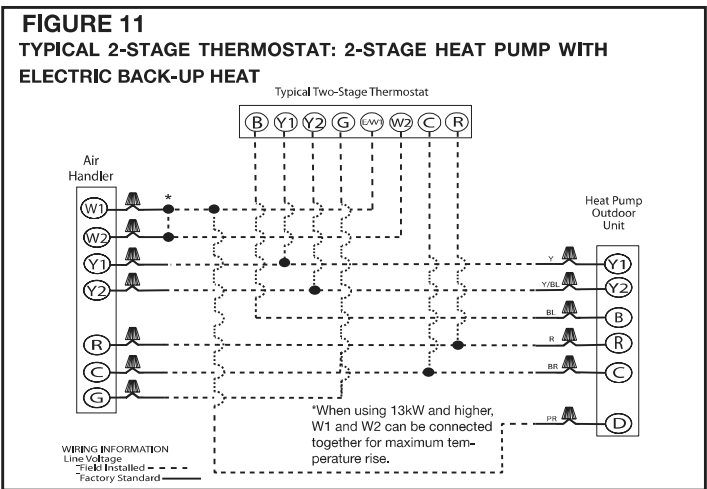
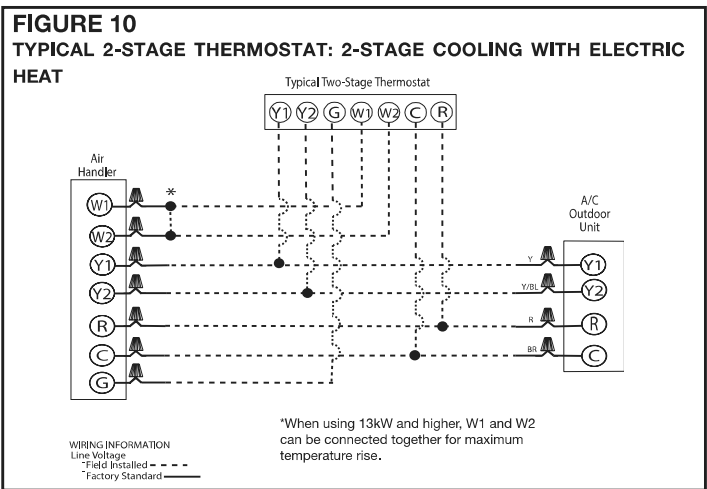
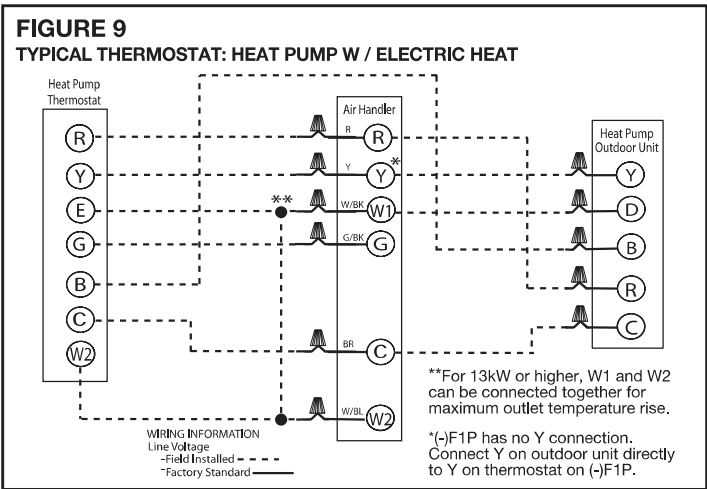
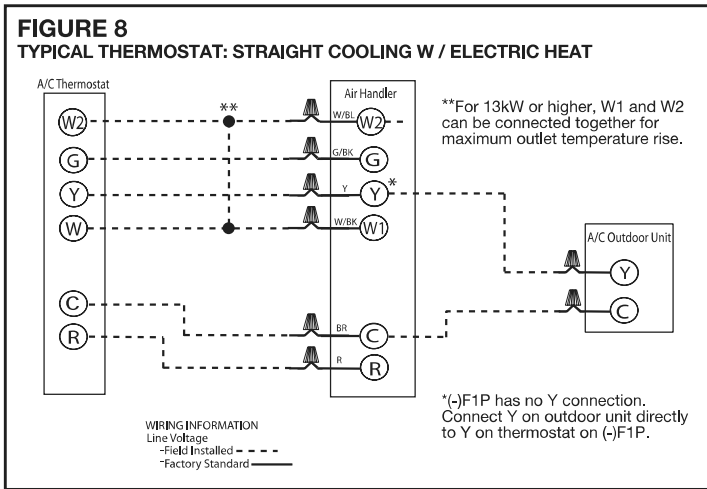

FIGURE 12
 (-)F1PY/(-)F2TY TYPICAL SINGLE-STAGE THERMOSTAT: SINGLE-STAGE COOLING WITH ELECTRIC HEAT.

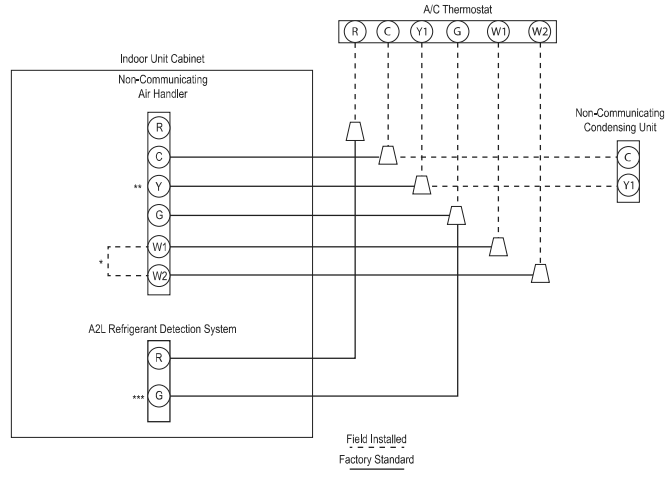

FIGURE 13
 (-)F1PY/(-)F2TY TYPICAL SINGLE-STAGE THERMOSTAT: SINGLE-STAGE HEAT PUMP WITH ELECTRIC HEAT.

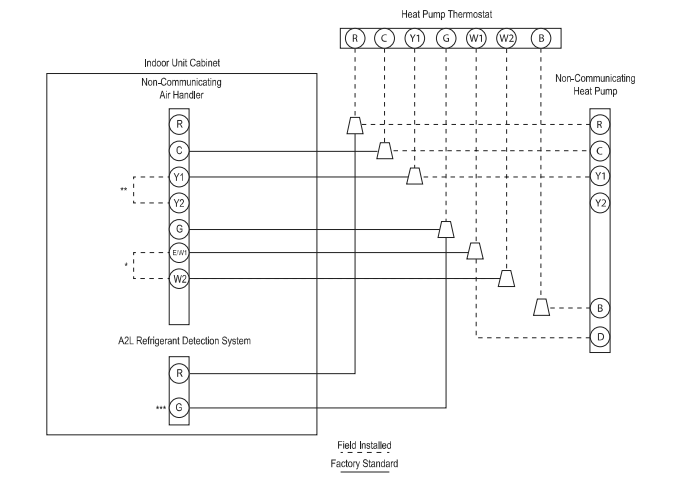

FIGURE 14
 (-)F2TY TYPICAL TWO-STAGE THERMOSTAT: TWO-STAGE COOLING WITH ELECTRIC HEAT.

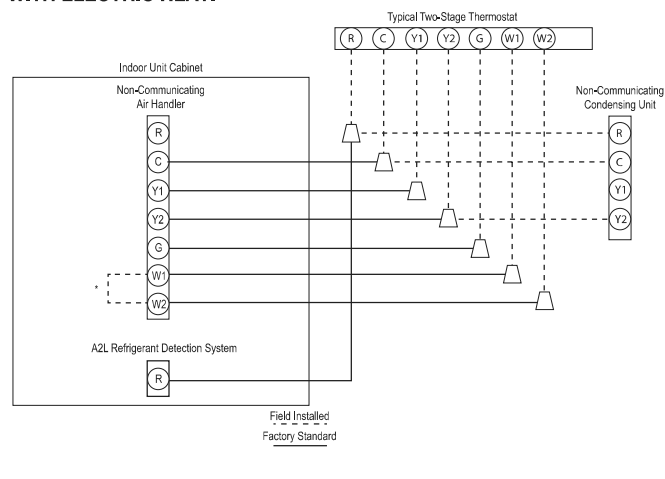
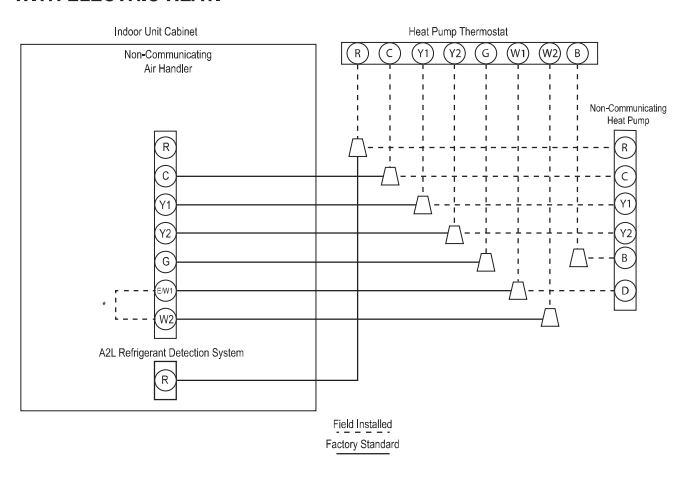

FIGURE 15
 (-)F2TY TYPICAL TWO-STAGE THERMOSTAT: TWO-STAGE HEAT PUMP WITH ELECTRIC HEAT.



3.12 AIR-FLOW PERFORMANCE

Air-flow performance data is based on cooling performance with a coil and filter in place. Select performance table for appropriate unit size, voltage and number of electric heaters to be used. Make sure duct system external static pressure applied to unit allows operation within the minimum and maximum limits shown in Section 3.13.1 below for both cooling and electric heat operation. See Section 3.13.3 for air-flow performance over a range of external static pressures for each speed tap.

3.12.1 GENERAL AIR-FLOW OPERATING LIMITS

Cooling Tons Nominal	1.5	2	2.5	3
Heat Pump or Air Conditioning Maximum Heat/Cool CFM [L/s] (37.5 CFM [18 L/s]/1,000 BTUH) (450 CFM [212 L/s]/Ton Nominal)	675 [319]	900 [425]	1125 [531]	1350 [637]
Heat Pump or Air Conditioning Nominal Heat/Cool CFM [L/s] (33.3 CFM [16 L/s]/1,000 BTUH) (400 CFM [189 L/s]/Ton Nominal)	600 [283]	800 [378]	1000 [472]	1200 [566]
Heat Pump or Air Conditioning Minimum Heat/Cool CFM [L/s] (30.0 CFM [14 L/s]/1,200 BTUH) (360 CFM [170 L/s]/Ton Nominal)	540 [255]	720 [340]	900 [425]	1080 [510]
Maximum kW Electric Heating 10 & Minimum Electric Heat CFM [L/s]	8 450 [212]	10 690 [325]	10 690 [325]	690 [325]
Maximum Electric Heat Rise °F [°C]	53° [11.65]	93° [33.8]	93° [33.8]	93° [33.8]

3.12.2 SELECTING INDOOR BLOWER MOTOR SPEED

The (-)F1PY and (-)F2TY air-handlers must be configured in the field to assure proper air-flow is delivered for the particular application it is being used in. Refer to the AIR-FLOW PERFORMANCE DATA in Section 3.13.3 to determine which speed tap is appropriate for the application.

3.12.2.1 (-)F1PY MODELS (PSC MOTOR)

(-)F1PY models are designed to be matched to a specific capacity outdoor unit, 1.5, 2.0, 2.5, and 3.0 tons. They have PSC motors with 2 blower motor speed taps, low speed for applications with an external static pressure of up to 0.3" W.C. and high speed for applications with an external static pressure from 0.3" to 0.7" W.C. All models are shipped from the factory wired for high speed operation.

The speed selection is made on the Blower Control Board. To change from high speed to low speed, remove the BLACK motor lead from the COM terminal, remove insulated cap from the end of the RED motor lead located in the control box and plug it into the terminal on the end of the BLACK motor lead to prevent it from shorting to ground. Attach RED wire to the COM terminal on the Blower Control Board.

3.12.2.2 (-)F2PY MODELS (CONSTANT TORQUE ECM MOTOR) - 2 STAGE AIR-FLOW

(-)F2PY models are specifically designed to be matched with 2-stage outdoor units, but can also be matched with single-stage outdoor units if properly configured for the correct indoor air-flow as covered in Section 3.12.3.2. They have constant torque ECM motors with 5 blower motor speed taps, labeled T1 through T5. Speed selections are made on the low voltage terminal block located on the motor housing. Speed tap T1 is always dedicated to continuous fan operation and delivers approximately 50% of the speed tap T4 air-flow. When matching a (-)F2PY air-handler to a 2-stage outdoor unit, refer to the air-flow performance table in Section 3.12.3.2 to select the correct motor speed taps. The Yellow (Y1) and Blue (Y2) leads connected to the motor low voltage terminal block should be connected to terminals T2 and T3 on the motor low voltage terminal block for applications with a 1.5T, 2.5T or 3.5T outdoor and terminals T4 and T5 for applications with a 2T and 3T outdoor from the factory the air-handler is configured with the Yellow and Blue leads connected to terminals T4 and T5 on the motor low voltage terminal block.

3.12.2.3 (-)F2PY MODELS (CONSTANT TORQUE ECM MOTOR) - SINGLE STAGE AIR-FLOW

(-)F2PY air-handlers may be matched to single stage outdoor units if properly configured. When using a single speed outdoor unit, Y1 and Y2 thermostat wires must connect to the Y2 (Yellow/Blue) pigtail wire on the air handler. Y1 (yellow) on the air handler may be left disconnected. For 1/2 tonnage outdoor units (1.5T & 2.5T) the blue wire from the control board should be connected to either T2 or T3 on the motor low voltage terminal block. For full tonnage outdoor units (2.0T and 3.0T) the blue wire from the control board should be connected to either T4 or T5 on the motor low voltage terminal block. Select the speed tap based on the general air-flow operating limits table 3.13.1 and static of the application.

3.12.3 AIR-FLOW PERFORMANCE DATA

3.12.3.1 (-)F1PY (PSC MOTOR)

Model/ Nominal Cooling Capacity	Manufacturer Recommended Air-Flow Range (Max/Min) CFM	Blower Size/ Motor HP # of Speeds	Motor Speed From Factory	Motor Speed	PSC										
					CFM Dry Delivery/filter/heaters/RPM/Watts										
					External Static Pressure-Inches W.C.										
						0.1	0.2	0.3	0.4	0.5	0.6	0.7	0.8	0.9	1.0
(-)F1PY18 1.5 tons	995/199	10x6 1/5 Hp 2 speed dual voltage	High	High	CFM	995	940	872	832	761	696	623	525	343	199
					RPM	937	957	974	987	1000	1018	1031	1052	1080	1103
					Watts	329	318	307	300	289	280	271	259	240	222
				Low	CFM	877	822	763	710	661	603	523	433	209	199
					RPM	851	880	905	925	946	964	995	1022	1072	1071
					Watts	244	234	226	219	212	204	193	183	156	154
(-)F1PY24 2 tons	1085/354	10x6 1/4 Hp 2 speed dual voltage	High	High	CFM	1085	1025	977	912	857	822	768	675	589	358
					RPM	1018	1030	1039	1047	1056	1065	1068	1083	1094	1123
					Watts	358	348	342	325	313	312	303	288	277	243
				Low	CFM	1058	1004	945	889	842	802	743	662	542	354
					RPM	1004	1018	1027	1037	1047	1049	1062	1075	1102	1117
					Watts	337	329	316	304	300	294	284	270	253	223
(-)F1PY30 2.5 tons	1411/359	10x8T 1/3 Hp 2 speed dual voltage	High	High	CFM	1411	1337	1294	1218	1143	1056	950	867	705	378
					RPM	1023	1036	1048	1057	1070	1082	1085	1075	1081	1116
					Watts	483	462	451	433	414	396	374	358	331	283
				Low	CFM	1266	1215	1160	1097	1028	945	870	758	605	359
					RPM	933	955	983	1005	1023	1042	1057	1075	1095	1121
					Watts	407	392	380	365	350	330	315	292	271	235
(-)F1PY36 3 tons	1363/1048	10x8T 1/2 Hp 2 speed dual voltage	High	High	CFM	1486	1425	1353	1307	1184	1110	1018	931	725	588
					RPM	1079	990	1091	1103	1115	1121	1114	838	1144	1125
					Watts	692	664	644	631	612	593	582	571	528	515
				Low	CFM	1399	1324	1276	1203	1115	1021	960	905	725	427
					RPM	1021	1036	1044	1057	1066	1077	1103	1110	1116	1128
					Watts	507	488	472	450	432	410	394	379	340	293

NOTE:

- All 208/240V PSC motors have voltage taps for 208 and 240 volts.
- All 208/240V PSC motors have shipped on high speed and for 240 volt applications.
- If the application external static is less than 0.5" WC, adjust the motor speed to the low static speed as described below.
 - Unplug the black motor wire off the relay on the control board and plug in the red motor wire.
 - Replace the cap on the black motor wire.
- Voltage change (208/240V motors):
 - Move the orange lead to transformer 208V tap. Replace the wire cap on 240V tap.
 - Unplug the purple motor wire off the transformer and plug in the yellow motor wire.
 - Replace the cap on the purple motor wire.
- The above air-flow table lists the air-flow information for air handlers with maximum heater allowed for each model.

3.12.3 AIR-FLOW PERFORMANCE DATA (continued)

3.12.3.2 (-)F2TY (CONSTANT TORQUE ECM MOTOR)

Model/ Nominal Cooling Capacity	Air-Flow Range (Max/ Min) CFM	Manufacturer Recommended Blower Size/ Motor HP # of Speeds	Motor Speed From Factory	Motor Speed	CFM Dry Delivery/filter/heaters/RPM/Watts										
					External Static Pressure-Inches W.C.										
						0.1	0.2	0.3	0.4	0.5	0.6	0.7	0.8	0.9	1.0
(-)F2TY24 1.5 tons	825/510	10x6 1/3 Hp 2 speed dual voltage	4	2	CFM	533	486	462	426	359	327	315	301	253	206
					RPM	687	740	769	821	893	931	970	1025	1077	1102
					Watts	63.9	69.1	72.2	78.6	84.4	86.3	90.2	95.7	100.4	103.5
			5	3	CFM	692	660	623	598	588	542	497	464	411	349
					RPM	811	844	880	917	953	984	1045	1090	1134	1163
					Watts	109.4	114.5	119.1	123.1	128.5	133	141	146.2	153.2	145.3
(-)F2TY24 2 tons	973/733	10x6 1/3 Hp 2 speed dual voltage	4	4	CFM	566	529	502	454	426	361	324	303	288	246
					RPM	713	755	795	837	896	951	997	1039	1097	1129
					Watts	71.3	75.2	79.1	83.9	89.2	94.5	99.4	104.8	112.1	114
			5	5	CFM	842	808	788	762	738	715	681	659	527	372
					RPM	938	976	1002	1028	1056	1091	1123	1132	1159	1175
					Watts	176.6	183.8	189.6	194.1	198.5	203.3	211.4	208.2	182.4	151
(-)F2TY36 2.5 tons	1145/894	10x8 1/2 Hp 2 speed dual voltage	4	2	CFM	649	651	629	564	497	441	375	325	272	218
					RPM	611	635	662	715	776	834	896	928	995	1054
					Watts	65.3	67.4	69.7	75.9	79.2	86.8	92.7	95.9	102.2	106.9
			5	3	CFM	1021	956	929	885	838	802	757	708	664	605
					RPM	777	824	862	902	939	985	1027	1070	1109	1148
					Watts	157.4	164.7	173.3	180	185.6	193.6	201.3	210.7	217.3	220.8
(-)F2TY36 3 tons	1306/1040	10x8 1/2 Hp 2 speed dual voltage	4	4	CFM	674	660	601	523	470	391	351	313	255	201
					RPM	628	671	728	791	860	899	932	983	1042	1090
					Watts	70.4	75.3	81.4	86.6	94.4	98.4	101.4	107	113.1	117.3
			5	5	CFM	1122	1087	1054	1006	960	932	894	838	772	666
					RPM	843	883	924	961	1002	1033	1070	1111	1144	1161
					Watts	206.1	215.2	225	233.1	241.5	247.3	257	265.6	265.9	240.5

NOTE:

All (-)F2TY air-handlers have 5 speed constant torque motors.

Speed tap 1 is for continuous fan. Speed tap 2 (low static) and speed tap 3 (high static) are for lower tonnage (1.5 or 2.5 tons). Speed tap 4 (low static) and speed tap 5 (high static) are for higher tonnage (2.0 or 3.0 tons).

(-)F2TY air handlers are always shipped from factory at speed taps 4 and 5.

- The air-flow for continuous fan (speed tap 1) is always set at 50% of the speed tap 4.
- The above air-flow table lists the air-flow information for air handlers with maximum heater allowed for each model.

4.0 START-UP

4.1 PRE-START CHECKLIST

PRE-START CHECKLIST	
<input type="checkbox"/> YES <input type="checkbox"/> NO	Is unit properly located, level, secure and serviceable?
<input type="checkbox"/> YES <input type="checkbox"/> NO	Has auxiliary pan been provided under the unit with separate drain? (Units installed above a finished ceiling).
<input type="checkbox"/> YES <input type="checkbox"/> NO	Is condensate line properly sized, run, trapped, pitched and tested?
<input type="checkbox"/> YES <input type="checkbox"/> NO	Is ductwork correctly sized, run, taped and insulated?
<input type="checkbox"/> YES <input type="checkbox"/> NO	Have all cabinet openings and wiring been sealed with caulking?
<input type="checkbox"/> YES <input type="checkbox"/> NO	Is the filter clean, in place and of adequate size?
<input type="checkbox"/> YES <input type="checkbox"/> NO	Is the wiring tight, correct and to the wiring diagram?
<input type="checkbox"/> YES <input type="checkbox"/> NO	Is the unit properly grounded and protected (fused)?
<input type="checkbox"/> YES <input type="checkbox"/> NO	Is the thermostat heat anticipator been set properly?
<input type="checkbox"/> YES <input type="checkbox"/> NO	Is the unit circuit breaker(s) rotated properly "on" up - "off" down?
<input type="checkbox"/> YES <input type="checkbox"/> NO	Are the unit circuit breaker(s) line lug cover(s) in place?
<input type="checkbox"/> YES <input type="checkbox"/> NO	Are all access panels in place and secure?
Refer to outdoor unit installation instructions for system start-up instructions and refrigerant charging instructions.	

4.2 SYSTEM START-UP AND OPERATIONAL CHECK-OUT

After the air-handler and other system components have been installed and the Pre-Start Checklist has been completed, the system should be started up and an operational check-out should be performed. The operational check-out includes checking sequence of operation of the controls, air-flow, and refrigerant charge. If the controls are not found to be functioning properly, or the air-flow or refrigerant charge are not within specifications, corrective action must be taken. The following sections are provided to assist the installer with the operational check-out.

4.3 SEQUENCE OF OPERATION

4.3.1 COOLING MODE

When the thermostat calls for cooling, the G terminal on the blower control board is energized which in turn energizes the indoor blower motor. This causes the indoor blower to circulate air through the air-handler and duct system during the cooling cycle. For (-) F2TY air-handlers, the Y terminal on the blower control board is also energized which tells the blower control board to energize the cooling speed on the motor instead of the reduced CFM continuous fan speed.

When the thermostat call is satisfied or the thermostat is turned to the off position. The G and Y terminals on the blower control board are de-energized. A time delay programmed into the (-)F1PY blower control board or (-)F2TY motor keeps the blower motor energized for an additional 30 seconds to extract the residual cooling from the cold indoor coil.

4.3.2 ELECTRIC HEAT MODE

When the thermostat calls for the 1st stage of heat, the W1 terminal on the blower control board is energized. This energizes the indoor blower motor and all of the electric heater elements for heater kits with 10kW of heat or less and the 1st stage elements for 13kW heater kits and higher. If W1 and W2 thermostat pigtailed at the air-handler are wired together on 13kW heater kits and higher, all of the elements to be energized. For 13kW heater kits and higher, a 2-stage heat thermostat can be used to energize the W2 terminal on the blower control board upon a call for a 2nd stage of heat which will in turn will energize the 2nd stage heater elements. The heater kit will cycle between the 1st and 2nd stages of heat at the direction of the thermostat.

When the thermostat call for heat is satisfied or the thermostat is turned to the off position, the W1 terminal on the blower control board is de-energized which will de-energize the heating elements in a few seconds as the bimetallic disc in the sequencer cools. The blower motor will be de-energized 75 seconds after the call for heat ends.

4.3.3 HEAT PUMP HEATING MODE

When the heat pump thermostat is set to “heat” mode, the “B” terminal on the outdoor unit is energized which energizes the reversing valve and switches it to the heating position. When the thermostat calls for heat, the G terminal on the blower control board is energized which in turn energizes the indoor blower motor. This causes the indoor blower to circulate air through the air-handler and duct system during the heating cycle. For (-)F2TY air-handlers, the Y terminal on the blower control board is also energized which tells the blower control board to energize the heating speed on the motor instead of the reduced CFM continuous fan speed. The heating speed on the motor is the same as the cooling speed.

Should the room temperature continue to fall when the system is operating in the heat pump heating mode, the thermostat energizes the W2 terminal on the blower control board which energizes supplemental electric heat. For 13kW heater kits and larger, the W1 and W2 pigtails can be connected together for maximum supplemental heat for 2nd stage or wired to the W1 and W2 terminals on the thermostat separately to provide a 3rd stage of heat as needed.

When the thermostat call for heat is satisfied, the G and Y terminals on the blower control board are de-energized. A time delay programmed into the (-)F2TY blower control board or (-)F1PY motor keeps the blower motor energized for an additional 30 seconds to extract the residual heat from the warm indoor coil.

4.3.4 SUPPLEMENTAL ELECTRIC HEAT DURING DEFROST

Supplemental electric heat during the defrost cycle can be provided by running a wire from the purple pigtail wire (from D terminal on defrost control) on the outdoor heat pump unit to the W1 pigtail on the air-handler. This will energize the electric heat during the defrost cycle to prevent cold air from being discharged from the supply registers in the home.

For the most economical operation and if cold discharge air is not a concern, do not run the wire from the purple pigtail on the outdoor unit to the W1 pigtail on the air-handler. In this case, supplemental heat will only be energized if the thermostat energizes the 2nd stage of heat during the defrost cycle due to a significant drop in room temperature.

4.3.5 EMERGENCY HEAT (HEAT PUMP)

If heat pump thermostat is set to the “Emergency Heat” mode, the outdoor unit will be prevented from operating and heat will be provided solely by the electric heater. The electric heater elements and indoor blower motor will be energized any time there is a call for heat with no compressor and outdoor fan operation. A jumper should be installed between the W1 and E terminals on the thermostat sub-base so a call for emergency heat will be transferred to the 1st stage of heat of the thermostat. The indoor blower will cycle on and off with the electric heater elements when the thermostat fan setting is set to the “auto” mode, although there will be a 75 second delay off period for the blower motor after the call for heat ends.

4.3.6 THERMOSTAT FAN SETTING

If the thermostat “FAN” setting is adjusted to the “AUTO” position, the indoor blower motor will only operate when there is a call for cooling or heating. If the setting is adjusted to the “ON” position, the indoor blower motor will operate continuously. On (-)F1T models, the indoor blower motor will operate at a reduced speed when there is no call for cooling and heating to reduce power consumption and noise.

4.4 CORRECTING ELECTRIC HEAT kW FOR VOLTAGE

The actual electric heat kW varies with the supply voltage. Use the following formula to correct the heater rated kW at voltages other than rated voltage.

$$\text{Actual kW} = \text{Rated kW} \times (\text{Actual Voltage}^2 / \text{Rated Voltage}^2).$$

4.5 CALCULATING ELECTRIC HEAT CAPACITY IN BTUH

Use the following formula to convert heater kW to heating capacity in BTUH.

$$\text{BTUH Capacity} = \text{kW} \times 3412$$

$$(\text{Where } 3412 = \text{BTUH per kW})$$

4.6 CHECKING INDOOR AIR-FLOW

4.6.1 ESTIMATING CFM USING EXTERNAL STATIC PRESSURE

A common method of checking indoor is to measure the external static pressure that the air-handler is working against and then referring to the air-flow data in Section 3.13.3. Measuring external static pressure to a high degree of precision in the field is challenging, so keep in mind that the CFM determined by this method is an estimate, but is accurate enough for all practical purposes.

To determine external static pressure, the static pressure should be measured in inches of water column across the air-handler using an incline manometer, digital static pressure meter, or a Magnahelic. The static pressure inside the return plenum should be measured as close to the air-handler as possible and must be measured between any external filter rack and the unit so the pressure drop across the filter is accounted for. The static pressure inside the supply plenum should be measured at a point about halfway between the air-handler and the first elbow or the end of the plenum. Total external static pressure is the sum of the return and supply plenum static pressures. Even though the return plenum static pressure is a negative pressure, it must be added to the supply plenum static pressure, ignoring the negative sign. The supply and return plenum static pressure tubing can also be connected to both pressure ports of the pressure measuring device which will automatically add the two pressures together.

4.6.2 ESTIMATING CFM USING ELECTRIC HEAT TEMPERATURE RISE

If the air-handler is equipped with an electric heater, the CFM can be estimated using the air temperature rise across the air-handler with the heater and blower both energized once the unit has run long enough for the temperatures to stabilize. As with determining CFM using external static pressure, the CFM determined by this method is an estimate, but is accurate enough for all practical purposes. Measure the return air temperature as close to the unit as possible and the supply air temperature about half way from the air-handler to the first elbow or end of the supply plenum. Use the following formula to calculate CFM once the temperature rise is determined.

Elevation (Feet)	Elevation Factor
Sea Level	1.08
500	0.98
1000	0.96
1500	0.95
2000	0.93
2500	0.91
3000	0.90
3500	0.88
4000	0.86
5000	0.83
6000	0.83
7000	0.77
8000	0.74
9000	0.72
10000	0.69

CFM = Heating BTUH / (Elevation Factor × Temp Rise °F)

NOTE: Refer to Section 4.5 to determine Heating BTUH and the following chart for Elevation Factor.

4.7 CHECKING REFRIGERANT CHARGE

System refrigerant charging should only be performed after the indoor air-flow is confirmed to be correct for the application. Once the air-flow is confirmed, refer to the manufacturer's outdoor unit charging chart and installation manual for the proper charging procedure for the system.

NOTE: The charging method for systems with a fixed orifice (piston) will likely be different than systems with TXV's.

5.0 COMPONENTS & CONTROLS

5.1 BLOWER MOTOR

All (-)F1PY models have 2-speed single-phase permanent split capacitor (PSC) style motors.

- The 208/240 volt models also have voltage taps that allow the motor to be configured to restore full air-flow performance in 208 volt applications.
- The low speed tap is for applications with duct system external static pressures up to 0.5" W.C. and the high speed tap is for applications with external static pressures from 0.5 – 0.7" W.C.
- A run capacitor is required for the PSC motors which is mounted on the blower housing. Speed and voltage change instructions are detailed in Sections 3.13.1 & 3.14.2 of this manual.

All (-)F2TY models have 5-speed constant torque electronically commutated (ECM) style motors that are significantly more efficient than PSC motors.

- The 208/240 volt models **do not** require the motor to be reconfigured for 208 volt applications, although the control transformer must still be reconfigured for 208 volt applications.
- The motor has a control module mounted on the end of the motor opposite the shaft end which is replaceable should only the control module itself fail.
- Constant torque ECM motors do not require a run capacitor.
- A terminal block on the motor shell is provided for the 5 speed taps, labeled T1 – T5. The speed taps are 24VAC inputs. **Do not connect line voltage to these speed taps.** T1 provides the slowest speed and is dedicated to continuous fan operation. T2 – T5 are for cooling & heating operation and are selectable at the terminal block using a single wire with an insulated terminal that plugs onto the terminals in the terminal block. Speed change instructions are detailed in Section 3.14.2.
- The constant torque motor has a built in soft start that will ramp the motor up to speed gradually.
- An off-delay is built into the control of the motor that keeps the motor energized for 30 seconds after 24 volts is removed from all speed tap terminals.
- If two of the speed tap terminals (T1 – T5) are energized with 24 volts simultaneously, the motor will operate at the higher of the 2 speeds. An example of this is when the G and Y thermostat inputs are both energized in the cooling or heat pump heating mode. In this case, T1 (continuous fan) and a higher numbered speed tap will both be energized resulting in the motor operating at the higher speed to support the cooling or heat pump heating air-flow requirement.
- The air-flow delivery rate for a constant torque ECM motor will not decrease as much as it does with a PSC motor as external static pressure increases.

5.2 MOTOR RUN CAPACITOR

Only the (-)F1PY models have a run capacitors due to the fact they have PSC motors. The capacitor is mounted on the blower housing using a sheet metal strap. The microfarad (mfd) & voltage ratings vary depending on the blower motor and must be replaced with one with the same rating, except 370V rated capacitors can always be replaced with a 440V rated capacitor.

5.3 BLOWER CONTROL

An electronic blower control is provided to control blower motor & electric heat operation and is located inside the control box attached to the blower housing. The blower control in the (-)F1PY and (-)F2TY operate differently as described below.

(-)F1PY Blower Control

- The contacts in the on-board relay (BR) are used to connect line voltage to the motor speed tap when there is a call for motor operation. Motor speed changes are made by switching motor speed taps at this relay.
- The control has an on-board 3 amp automotive style fuse to protect the control circuit.
- A plug on the electric heater kit wiring harness plugs into a 4 pin plug receptacle on the blower control to allow control of the electric heater by the blower control based on thermostat input.
- There is a 5-pin connector for the thermostat pigtail harness to connect to. Wires from the thermostat do not connect directly to the blower control, but rather to the pigtails that are routed to the exterior of the air-handler cabinet.
- There is a 2 second on-delay for blower operation when there is a call for blower operation.
- There is a 30 second blower off-delay when a call for cooling or heat pump heating ends.
- There is a 75 second blower off-delay when a call for electric heating ends. This allows time for the contacts in the bi-metallic disc type heating sequencer to open which de-energizes the heater elements.

(-)F2TY Blower Control

- There are two 24V outputs on the blower control for controlling the motor, one for continuous fan and one for cooling & heating operation.
- Motor speed changes are made at the motor speed terminal block instead of on the blower control.
- The control has an on-board 3 amp automotive style fuse to protect the control circuit.
- A plug on the electric heater kit wiring harness plugs into a 4 pin plug receptacle on the blower control to allow control of the electric heater by the blower control based on thermostat input.
- There is a 6-pin connector for the thermostat pigtail harness to connect to. Wires from the thermostat do not connect directly to the blower control, but rather to the pigtails that are routed to the exterior of the air-handler cabinet.
- There is no on-delay for blower operation when there is a call for blower operation.
- There is no blower off-delay provided by the blower control when a call for cooling or heat pump heating ends since a 30 second off-delay is programmed into the constant torque ECM motor.

- There is a blower off-delay programmed into the blower control when a call for electric heating ends. The delay is 45 seconds for the White-Rodgers control and 30 seconds for the UTEC control. This off-delay is added to the 30 second off delay programmed into the motor for a total off-delay of 75 or 60 seconds. This allows time for the contacts in the bi-metallic disc type heating sequencer to open which de-energizes the heater elements.

5.4 BLOWER

The blower utilizes a forward curved centrifugal wheel. The blower housing is constructed from galvanized sheet metal. The motor is attached with a 4-arm belly band type mount that screws into the side of the blower housing. The control box attaches to the front of the blower housing for access through the blower access door. The blower slides into place on a track and is secured by 4 sheet metal screws.

5.5 TRANSFORMER

A 40VA transformer is located inside the control box attached to the blower housing which provides 24V control voltage for both the air-handler & the outdoor unit. The transformer in 208/240V models is wired from the factory for 240V applications, but has a separate 208V tap for 208V applications. The black wires connected to the 240V tap must be moved to the 208V tap when installing the air-handler in 208V applications to assure full 24V+ control voltage for reliable operation of the system controls.

5.6 INDOOR COIL ASSEMBLY

- The indoor coil slabs are a fin & tube design with enhanced aluminum fins & internally grooved aluminum tubing.
- All (-)F2TY air-handlers have non-bleed thermal expansion valves (TXV) for refrigerant control.
- (-)F1PY air-handlers can have either a non-bleed TXV or a fixed orifice (piston). The orifice may have to be changed when the air-handler is matched to certain outdoor units. The correct orifice will be supplied with the outdoor unit in cases where the orifice requires changing. (See Section 3.8)
- The 8th character in the model number indicates which type of metering device the air-handler is equipped with, "T" for TXV and "P" for piston. (See Section 2.3 for the model number nomenclature).
- All models have a self-draining polypropylene condensate drain pan to eliminate standing water.
- Copper stubs are provided for field tubing connections.

6.0 ACCESSORIES & KITS

6.1 ELECTRIC RESISTANCE HEATER KITS

- All (-)F1PY & (-)F2TY models are shipped with or without electric resistance heat.
- Electric heat kits ranging from 3kW to 10kW are available for field installation.
- Refer to Sections 3.11.6 and 3.11.7 for electric heat kit model numbers available for specific air-handler models along with electrical ratings & additional information regarding the heater kits.
- Heater kit installation instructions are provided with the heater kit.
- All heater kits utilize open wire nickel chromium heating elements.
- An automatic reset over-temperature limit is provided to shut off the heater elements should air-flow become too restricted or if the blower motor fails.
- 208/240V single-phase (“J” Voltage) heater kits are available.
- The heater kit is controlled by the blower control based on thermostat inputs.
- All heater kits are equipped with a circuit breaker style disconnect.
- Incoming electric power is connected directly to the heater kit power terminals.
- The heater kit is provided with 2 power wires that connect to the air-handler power terminal block, providing power to operate the blower motor and controls.
- The heater kit is also provided with a 4-pin connector that plugs into a mating plug on the blower control to allow the control of the heater based on thermostat inputs.

6.2 DRAIN PAN OVERFLOW SWITCH KIT

Drain Pan Overflow Switch RXHK-A01 is used to detect condensate drain blockage and will shut down the outdoor unit in order to prevent structural damage to the surrounding structures of the air handler. This accessory is also available as a factory installed option.

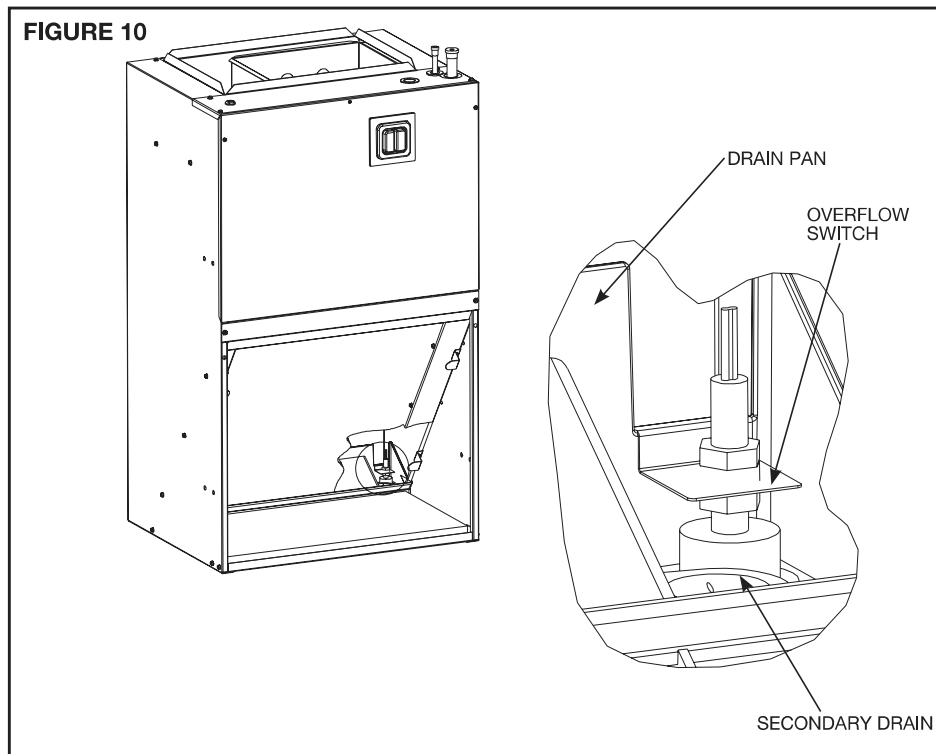

6.3 BOTTOM RETURN CONVERSION KIT

Bottom Return Conversion Kit RXHK- is used to divert the return air from the factory standard front return to a bottom return.

Accessory Number	Indoor Unit
RXHK-C01	(-)F1PY18
	(-)F1PY24
	(-)F2TY24
RXHK-C02	(-)F1PY30
	(-)F1PY36
	(-)F2TY36

FIGURE 11

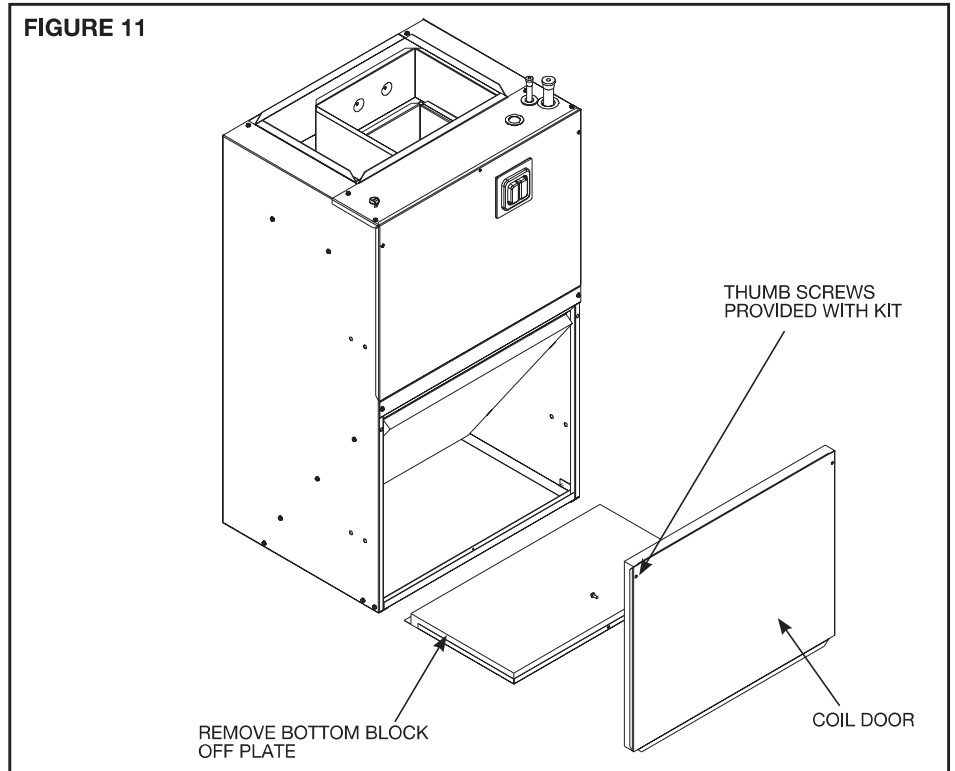

6.4 LOUVERED CABINET GRILLE

Louvered Cabinet Grille RXHK- is used as decorative grill which covers the return air opening of the front return air handler.

Accessory Number	Indoor Unit
RXHK-C01	(-)F1PY18
	(-)F1PY24
	(-)F2TY24
RXHK-C02	(-)F1PY30
	(-)F1PY36
	(-)F2TY36

FIGURE 12

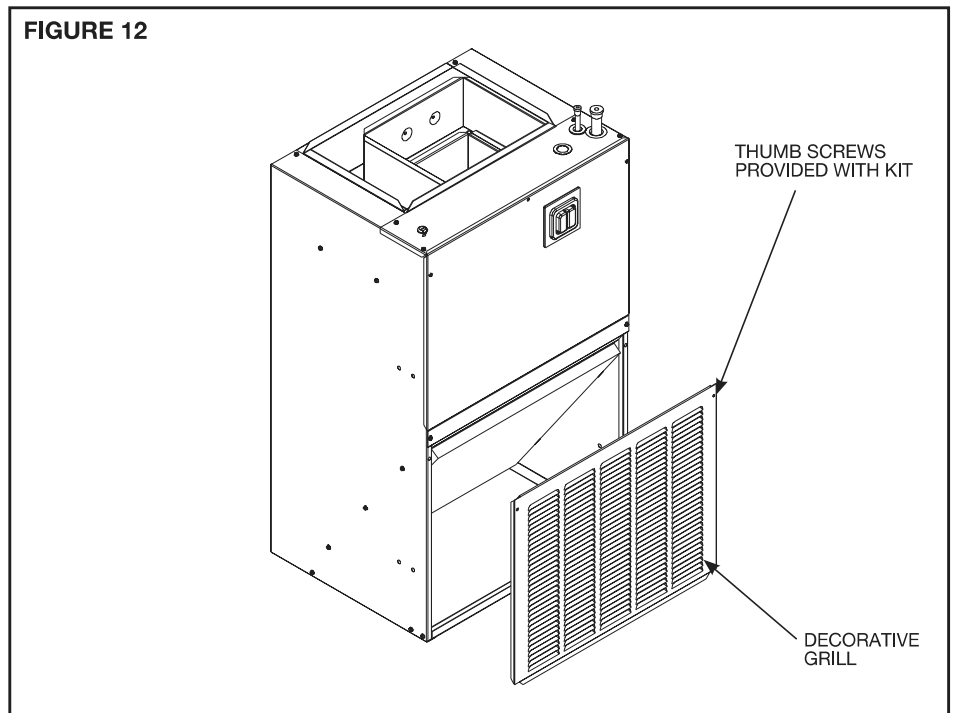

6.5 DECORATIVE WALL GRILLE

Decorative Wall Grille RXHK-D01/RXHK-D02 is used in applications where the air handler is installed in a closet or interior wall and allows adequate return air back to the unit.

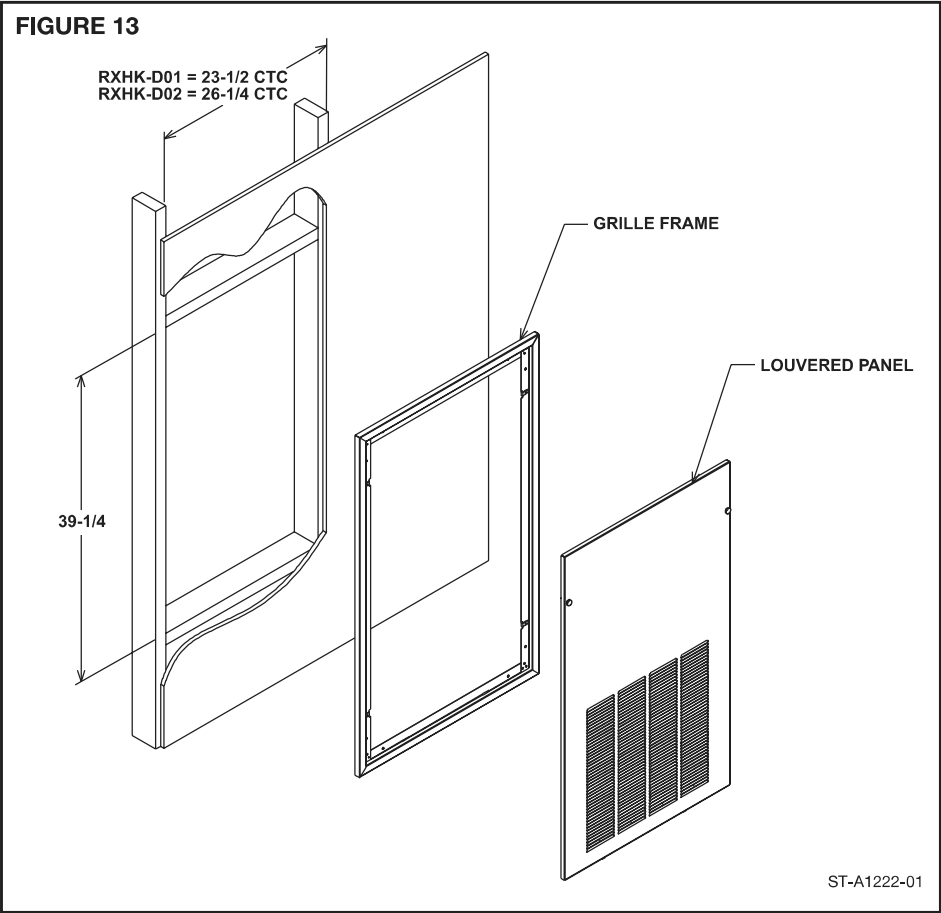

7.0 INDOOR SERVICE/MAINTENANCE

For continuing high performance, and to minimize possible equipment failure, it is essential that periodic maintenance be performed on this equipment. Consult your local dealer as to the proper frequency of maintenance and the availability of a maintenance contract.

IMPORTANT: Before performing any service or maintenance procedures, see the “Safety Information” (Section 1.0) at the front of this manual. Servicing shall be performed only as recommended by the manufacturer and by qualified personnel who are trained by a training organization or manufacturer accredited to teach national competency standards that may be set in legislation for servicing equipment with flammable refrigerant. The achieved competence should be documented by a certificate.

7.1 GENERAL GUIDELINES

Prior to beginning work on systems containing A2L REFRIGERANTS, safety checks are necessary to ensure that the risk of ignition is minimized. For repair to the REFRIGERATING SYSTEM, the following procedures shall be completed prior to conducting work on the system:

- Work shall be undertaken under a controlled procedure so as to minimize the risk of a flammable gas or vapor being present while the work is being performed.
- All maintenance staff and others working in the local area shall be instructed on the nature of work being carried out. Work in confined spaces shall be avoided.
- The area shall be checked with an appropriate refrigerant detector prior to and during work, to ensure the technician is aware of potentially toxic or flammable atmospheres. Ensure that the leak detection equipment being used is suitable for use with all applicable refrigerants, i.e. non-sparking, adequately sealed or intrinsically safe.
- If any hot work is to be conducted on the refrigerating equipment or any associated parts, appropriate fire extinguishing equipment shall be available to hand. Have a dry powder or CO2 fire extinguisher adjacent to the charging area.
- No person carrying out work in relation to a REFRIGERATING SYSTEM which involves exposing any pipe work shall use any sources of ignition in such a manner that it may lead to the risk of fire or explosion. All possible ignition sources, including cigarette smoking, should be kept sufficiently far away from the site of installation, repairing, removing and disposal, during which refrigerant can possibly be released to the surrounding space. Prior to work taking place, the area around the equipment is to be surveyed to make sure that there are no flammable hazards or ignition risks. “No Smoking” signs shall be displayed.
- Ensure that the area is in the open or that it is adequately ventilated before breaking into the system or conducting any hot work. A degree of ventilation shall continue during the period that the work is carried out. The ventilation should safely disperse any released refrigerant and preferably expel it externally into the atmosphere.

7.2 CHECKS TO THE REFRIGERANT EQUIPMENT

Where electrical components are being changed, they shall be fit for the purpose and to the correct specification. At all times the manufacturer’s maintenance and service guidelines shall be followed. If in doubt, consult the manufacturer’s technical department for assistance.

The following checks shall be applied to installations using A2L REFRIGERANTS:

- The actual REFRIGERANT CHARGE is in accordance with the room size within which the refrigerant containing parts are installed.
- The ventilation machinery and outlets are operating adequately and are not obstructed.
- If an indirect refrigerating circuit is being used, the secondary circuit shall be checked for the presence of refrigerant.
- Marking to the equipment continues to be visible and legible. Markings and signs that are illegible shall be corrected.
- Refrigerating pipe or components are installed in a position where they are unlikely to be exposed to any substance which may corrode refrigerant containing components, unless the components are constructed of materials which are inherently resistant to being corroded or are suitably protected against being so corroded.

7.3 CHECKS TO ELECTRICAL DEVICES

Repair and maintenance to electrical components shall include initial safety checks and component inspection procedures. If a fault exists that could compromise safety, then no electrical supply shall be connected to the circuit until it is satisfactorily dealt with. If the fault cannot be corrected immediately but it is necessary to continue operation, an adequate temporary solution shall be used. This shall be reported to the owner of the equipment so all parties are advised. Initial safety checks shall include:

- That capacitors are discharged: this shall be done in a safe manner to avoid possibility of sparking.
- That no live electrical components and wiring are exposed while charging, recovering or purging the system.
- That there is continuity of earth bonding.

7.4 REPAIRS TO SEALED COMPONENTS

During repairs to sealed components, all electrical supplies shall be disconnected from the equipment being worked upon prior to any removal of sealed covers, etc. If it is absolutely necessary to have an electrical supply to equipment during servicing, then a permanently operating form of leak detection shall be located at the most critical point to warn of a potentially hazardous situation. Particular attention shall be paid to the following to ensure that by working on electrical components, the casing is not altered in such a way that the level of protection is affected. This shall include damage to cables, excessive number of connections, terminals not made to original specification, damage to seals, incorrect fitting of glands, etc.

- Ensure that the apparatus is mounted securely.
- Ensure that seals or sealing materials have not degraded to the point that they no longer serve the purpose of preventing the ingress of flammable atmospheres.
- Replacement parts shall be in accordance with the manufacturer’s specifications. Sealed electrical components shall be replaced.

7.5 REPAIR TO INTRINSICALLY SAFE COMPONENTS

Do not apply any permanent inductive or capacitance loads to the circuit without ensuring that this will not exceed the permissible voltage and current permitted for the equipment in use. Intrinsically safe components are the only types that can be worked on while live in the presence of a flammable atmosphere. The test apparatus shall be at the correct rating. Replace components only with parts specified by the manufacturer. Other parts may result in the ignition of refrigerant in the atmosphere from a leak.

NOTE: The use of silicon sealant can inhibit the effectiveness of some types of leak detection equipment. Intrinsically safe components must be replaced and do not have to be isolated prior to working on them.

7.6 CABLING

Check that cabling will not be subject to wear, corrosion, excessive pressure, vibration, sharp edges or any other adverse environmental effects. The check shall also take into account the effects of aging or continual vibration from sources such as compressors or fans.

7.7 DETECTION OF FLAMMABLE REFRIGERANTS

Under NO circumstances shall potential sources of ignition be used in the searching for or detection of refrigerant leaks. A halide torch (or any other detector using a naked flame) shall NOT be used. The following leak detection methods are deemed acceptable for all refrigerant systems:

- Electronic leak detectors may be used to detect refrigerant leaks but, in the case of FLAMMABLE REFRIGERANTS, the sensitivity may not be adequate, or may need re-calibration. (Detection equipment shall be calibrated in a refrigerant-free area.) Ensure that the detector is not a potential source of ignition and is suitable for the refrigerant used. Leak detection equipment shall be set at a percentage of the LFL of the refrigerant and shall be calibrated to the refrigerant employed, and the appropriate percentage of gas (25 % maximum) is confirmed.
- Leak detection fluids (such as bubble method or fluorescent method agents) are also suitable for use with most refrigerants but the use of detergents containing chlorine shall be avoided as the chlorine may react with the refrigerant and corrode the copper pipe-work. If a leak is suspected, all naked flames shall be removed/extinguished. If a leakage of refrigerant is found which requires brazing, all of the refrigerant shall be recovered from the system, or isolated (by means of shut off valves) in a part of the system remote from the leak. Removal of refrigerant shall be according to the next section (7.8 Removal and Evacuation).

7.8 REMOVAL AND EVACUATION

When breaking into the refrigerant circuit to make repairs or for any other purpose, it is important that best practice is followed for A2L refrigerants. The following procedure shall be adhered to safely remove refrigerant following local and national regulations:

Evacuate Purge the circuit with inert gas (optional for A2L) Evacuate (optional for A2L) Continuously flush or purge with inert gas when using flame to open circuit Open the circuit The refrigerant charge shall be recovered into the correct recovery cylinders if venting is not allowed by local and national codes. For appliances containing A2L refrigerants, The system shall be purged with oxygen-free nitrogen to render the appliance safe for flammable refrigerants. This process might need to be repeated several times. Compressed air or oxygen shall NOT be used for purging refrigerant systems. The outlet for the vacuum pump shall NOT be close to any potential ignition sources, and ventilation shall be available. For appliances containing flammable refrigerants, refrigerants purging shall be achieved by breaking the vacuum in the system with oxygen-free nitrogen and continuing to fill until the working pressure is achieved, then venting to atmosphere, and finally pulling down to a vacuum (optional for A2L). This process shall be repeated until no refrigerant is within the system (optional for A2L). When the final oxygen-free nitrogen charge is used, the system shall be vented down to atmospheric pressure to enable work to take place. The outlet for the vacuum pump shall NOT be close to any potential ignition sources, and ventilation shall be available.

7.9 CHARGING PROCEDURES

- Ensure that contamination of different refrigerants does not occur when using charging equipment. Hoses or lines shall be as short as possible to minimize the amount of refrigerant contained in them.
- Cylinders shall be kept in an appropriate position according to the instructions.
- Ensure that the REFRIGERATING SYSTEM is earthed prior to charging the system with refrigerant.
- Label the system when charging is complete (if not already).
- Extreme care shall be taken not to overfill the REFRIGERATING SYSTEM.

Prior to recharging the system, it shall be pressure-tested with the appropriate purging gas. The system shall be leak-tested on completion of charging but prior to commissioning. A follow up leak test shall be carried out prior to leaving the site.

For more in-depth charging procedures, refer to Refrigerant Charging section of the Outdoor Installation Instructions.

7.10 RECOVERY

When removing refrigerant from a system, either for servicing or decommissioning, it is recommended good practice that all refrigerants are removed safely. When transferring refrigerant into cylinders, ensure that only appropriate refrigerant recovery cylinders are employed. Ensure that the correct number of cylinders for holding the total system charge is available. All cylinders to be used are designated for the recovered refrigerant and labeled for that refrigerant (i.e. special cylinders for the recovery of refrigerant). Cylinders shall be complete with pressure-relief valve and associated shut-off valves in good working order. Empty recovery cylinders are evacuated and, if possible, cooled before recovery occurs. The recovery equipment shall be in good working order with a set of instructions concerning the equipment that is at hand and shall be suitable for the recovery of the A2L refrigerant. If in doubt, the manufacturer should be consulted. In addition, a set of calibrated weighing scales shall be available and in good working order. Hoses shall be complete with leak-free disconnect couplings and in good condition. The recovered refrigerant shall be processed according to local legislation in the correct recovery cylinder, and the relevant waste transfer note arranged. Do not mix refrigerants in recovery units and especially not in cylinders. If compressors or compressor oils are to be removed, ensure that they have been evacuated to an acceptable level to make certain that refrigerant does not remain within the lubricant. The compressor body shall not be heated by an open flame or other ignition sources to accelerate this process. When oil is drained from a system, it shall be carried out safely.

7.11 DECOMMISSIONING AND LABELING

Before carrying out this procedure, it is essential that the technician is completely familiar with the equipment and all its detail. It is recommended good practice that all refrigerants are recovered safely. Prior to the task being carried out, an oil and refrigerant sample shall be taken in case analysis is required prior to re-use of recovered refrigerant. It is essential that electrical power is available before the task is commenced.

- a) Become familiar with the equipment and its operation.
- b) Isolate system electrically.
- c) Before attempting the procedure, ensure that: Mechanical handling equipment is available, if required, for handling refrigerant cylinders; All personal protective equipment is available and being used correctly; The recovery process is supervised at all times by a competent person; Recovery equipment and cylinders conform to the appropriate standards.
- d) Pump down refrigerant system, if possible.
- e) If a vacuum is not possible, make a manifold so that refrigerant can be removed from various parts of the system.
- f) Make sure that cylinder is situated on the scales before recovery takes place.
- g) Start the recovery machine and operate in accordance with instructions.
- h) Do not overfill cylinders (no more than 80 % volume liquid charge).
- i) Do not exceed the maximum working pressure of the cylinder, even temporarily.
- j) When the cylinders have been filled correctly and the process completed, make sure that the cylinders and the equipment are removed from site promptly and all isolation valves on the equipment are closed off.
- k) Recovered refrigerant shall not be charged into another REFRIGERATING SYSTEM unless it has been cleaned and checked. Equipment shall be labeled stating that it has been decommissioned and emptied of refrigerant. The label shall be dated and signed. Ensure that there are labels on the equipment stating the equipment contains FLAMMABLE REFRIGERANT.

7.12 AIR FILTER

Check the system filter every ninety days or as often as found to be necessary and if obstructed, clean or replace at once.

A qualified installer, service agency or HVAC professional should instruct the homeowner on how to access filters for regular maintenance.

IMPORTANT: Do not operate the system without a filter in place.

- New filters are available from a local distributor or home supply retailer.

7.13 INDOOR COIL, DRAIN PAN, DRAIN LINE

Inspect the indoor coil, drain pan, and drain line once each year for cleanliness and clean as necessary. Be sure to check the finned surface on the return side of the coil. It may be necessary to remove the air-filter and use a mirror and flashlight to view the return side of the coil.

NOTE: A proper filter is the best defense against a dirty coil. Regardless of the filter choice, proper air-flow and velocity also play a crucial role in how effective a filter will be. Most filters will lose their effectiveness when face velocities exceed 300 - 400 feet per minute. Excessive air velocity can allow particles to pass right through the media. Additionally, loaded or restrictive filters may lose their shape in higher air velocity applications and allow unfiltered air to bypass the filter altogether around the sides.

IMPORTANT: Coil and Drainpan Cleaning Method

Clean the finned surface of the indoor coil by rinsing the coil from both sides with **clean warm water** and/or with a vacuum with a soft brush attachment to remove accumulated contaminants and lint. It is important not to allow the tool to damage or bend the fins. Many chemical cleaners will attack the aluminum tubes which can cause refrigerant leaks. Therefore, use only clean warm water for cleaning aluminum tube evaporator coils. Do not use caustic household drain cleaners or bleach in the condensate pan or near the indoor coil as they will damage the aluminum fins and tubes.

7.14 BLOWER MOTOR AND WHEEL

Inspect the blower motor and wheel for cleanliness. It should be several years before it would become necessary to clean the blower motor and wheel.

- If it becomes necessary to remove the blower assembly from the unit, see instructions on removal and replacement of motor, blower, and blower wheel in Sections 7.5-7.7 below.
- The blower motor and wheel may be cleaned by using a vacuum with a soft brush attachment. Remove grease with a mild solvent such as hot water and detergent. Be careful not to disturb the balance weights (clips) on the blower wheel blades. Do not drop or bend wheel as balance will be affected.

7.15 MOTOR LUBRICATION

The blower motor sleeve bearings are pre-lubricated by the motor manufacturer and do not have oiling ports. Motor should operate for an indefinite period of time without additional lubrication.

7.16 BLOWER ASSEMBLY, MOTOR, BLOWER WHEEL REMOVAL & REPLACEMENT

Removing the blower assembly is not normally required for normal service and maintenance. Removal is necessary for replacement of defective parts such as motor, blower wheel. After extended use, removal of the blower assembly may become necessary for a thorough cleaning of the blower motor and wheel.

WARNING

If removal of the blower assembly is required, all disconnect switches supplying power to the equipment must be de-energized and locked (if not in sight of unit) so the field power wires can be safely removed from the blower assembly. Failure to do so can cause electrical shock resulting in personal injury or death.

Removal of the blower assembly in this style of air-handler is not as straightforward as with more conventional residential air-handlers due to its compact design. Therefore, Sections 7.5.1 – 7.5.3 are provided to aid the technician in that process. Removal of the blower assembly on the larger cabinet requires a partial disassembly of the cabinet, so the procedure in Section 7.5.3 may be preferable if only the motor needs to be removed for servicing or replacement.

7.16.1 SMALL CABINET BLOWER ASSEMBLY REMOVAL PROCEDURE (-F1PY18, (-F1PY24, AND (-F2TY24)

1. Disconnect all power to the air handler.
2. Disconnect all blower motor leads from the control board, capacitor, and speed tap. Reference wiring diagram for more detail.
3. If equipped with a heater kit, remove the 3 screws which attach the breaker/terminal block assembly to the blower shelf. This will help gain access to the screws in step 6. (1/4" Socket)

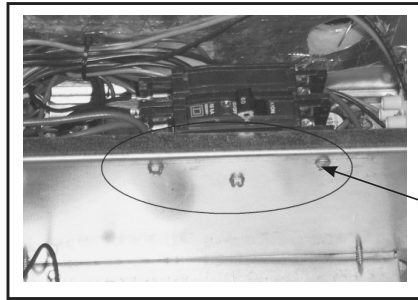

Remove Screws

4. Remove capacitor to help prevent damage to the coil. (1/4" Socket)

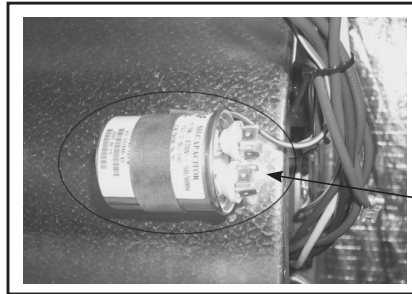

Remove
Capacitor

5. Install an 18" x 20" piece of cardboard over the coil as illustrated below to help protect the coil from damage.

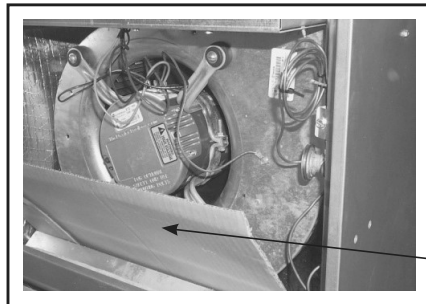

Install Cardboard

6. Remove the 3 sheet metal screws which attached the blower to the blower shelf located in the air handler control box. (3/8" Socket).

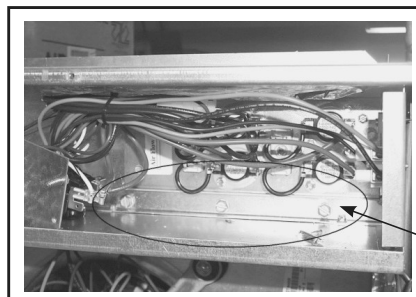

Remove Screws

7. Lower the blower and remove from air handler.

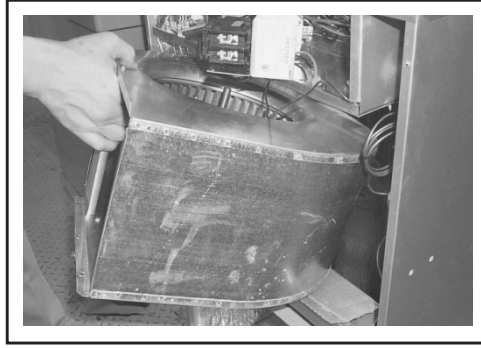

7.16.2 LARGE CABINET BLOWER ASSEMBLY REMOVAL PROCEDURE (-)F1PY30, (-)F1PY36, AND (-)F2TY36)

1. Disconnect all power to the air handler.
2. Disconnect all blower motor leads from the control board, capacitor, and speed tap. Reference wiring diagram for more detail.
3. If equipped with a heater kit, remove the 3 screws which attach the breaker/terminal block assembly to the blower shelf. This will help gain access to the screws in step 8. (1/4" Socket)

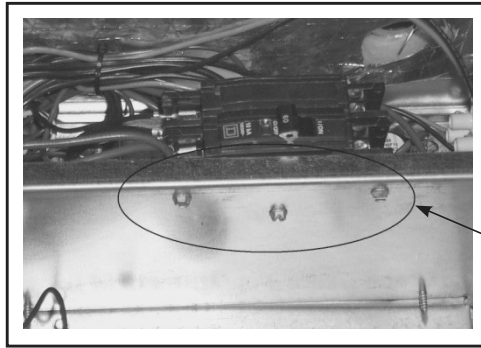

Remove Screws

4. Remove capacitor to help prevent damage to the coil. (1/4" Socket)

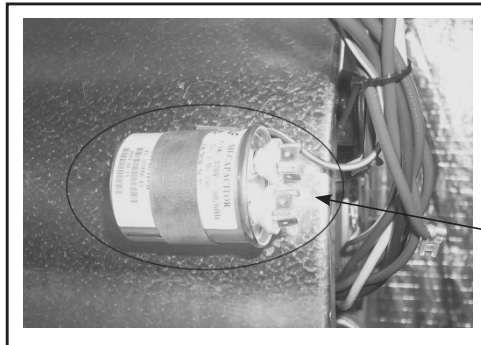

Remove
Capacitor

5. Install a 21" x 24" piece of cardboard over the coil as illustrated below to help protect the coil from damage.



Install Cardboard

6. Remove the top plate of the air handler by removing the 6 sheet metal screws attaching the plate to the top of the air handler. (1/4" Socket)

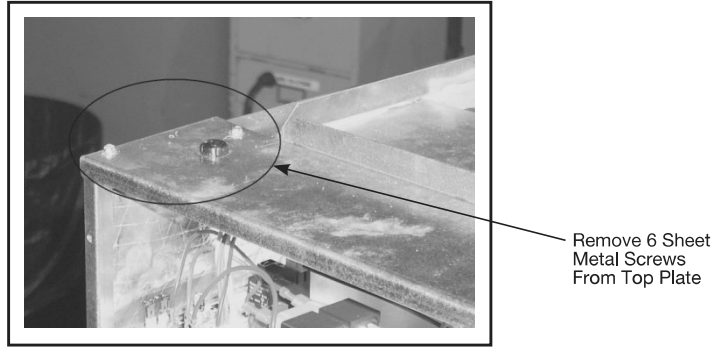

7. Remove 2 sheet metal screws attaching the middle brace to the air handler cabinet. (1/4" Socket)

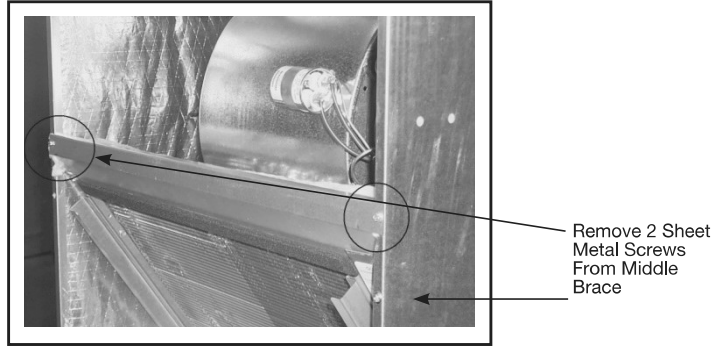

8. Remove 4 sheet metal screws (2 on each side of the air handler)

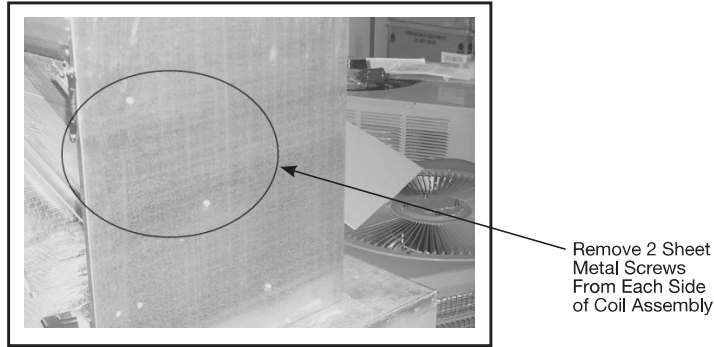

9. Tilt the coil assembly forward. (**NOTE:** Depending upon the amount of slack in the refrigerant lines, the system may have to be evacuated and the suction and liquid line of the air handler may have to be uninstalled from the system in order to prevent damage to the refrigerant lines which could result in a total loss of refrigerant)



10. Remove the 2 sheet metal screws that attached the blower to the bottom of the blower shelf. (1/4" Socket)

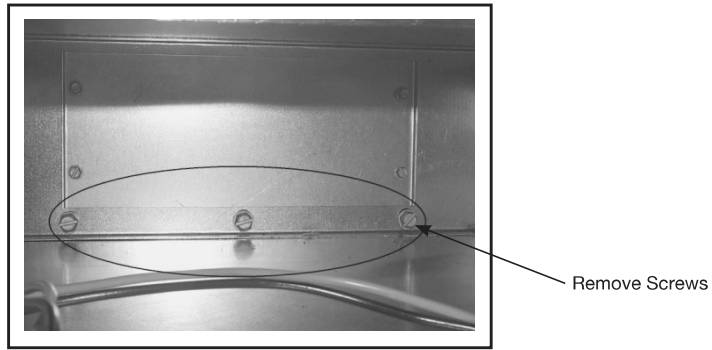

11. Remove the 3 sheet metal screws which attached the blower to the blower shelf located in the air handler control box. (3/8" Socket)

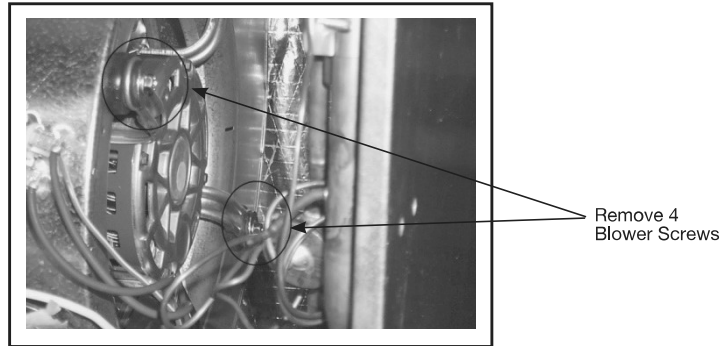

12. Lower the blower and turn assembly counter clockwise with the motor pointing towards the top of the air handler.

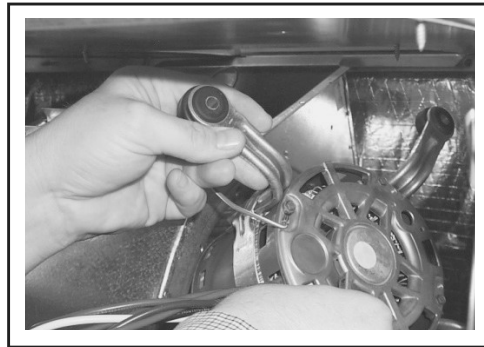

13. Remove the blower assembly from the air handler.



7.16.3 LARGE CABINET BLOWER MOTOR ONLY REMOVAL PROCEDURE ((-) F1PY30, (-)F1PY36, AND (-)F2TY36)

1. Disconnect all power to the air handler.
2. Disconnect all blower motor leads from the control board, capacitor, and speed tap. Reference wiring diagram for more detail.
3. If equipped with a heater kit, remove the 3 screws which attach the breaker/terminal block assembly to the blower shelf. This will help gain access to the screws in step 8. (1/4" Socket)

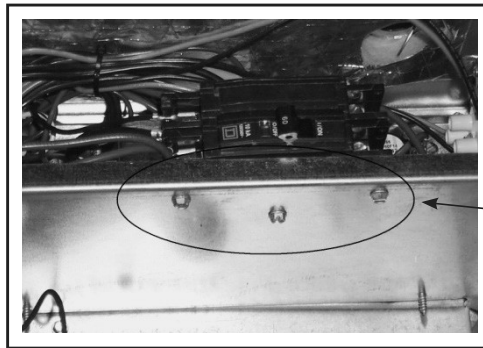

Remove Screws

4. Remove capacitor to help prevent damage to the coil. (1/4" Socket)



Remove Capacitor

5. Install a 21" x 24" piece of cardboard over the coil as illustrated below to help protect the coil from damage.

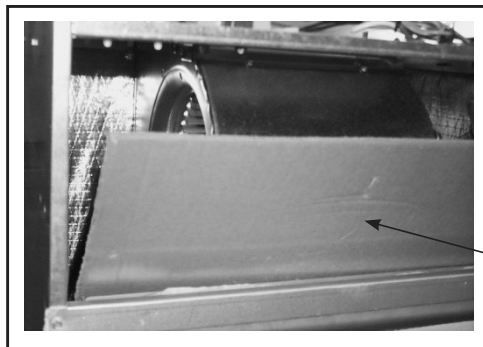

Install Cardboard

6. Remove/loosen set screw from the hub located on the left side of the blower.



Remove/Loosen Set Screw

7. Remove the 2 sheet metal screws that attached the blower to the bottom of the blower shelf. (1/4" Socket)

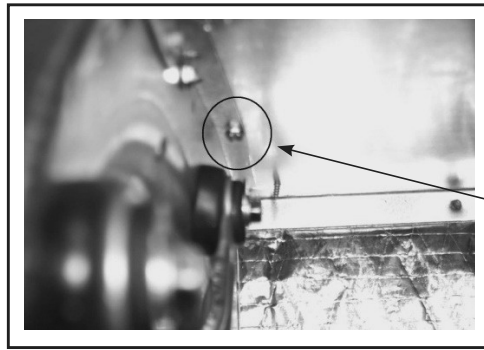

Remove Sheet Metal Screws From Each Side of Blower

8. Remove the 3 sheet metal screws which attached the blower to the blower shelf located in the air handler control box. (3/8" Socket)



Remove Screws

9. Lower the blower and slide the blower to the left side of the air handler.

10. Remove the 4 motor mount screws from the right side of the blower housing. (3/8" Socket)

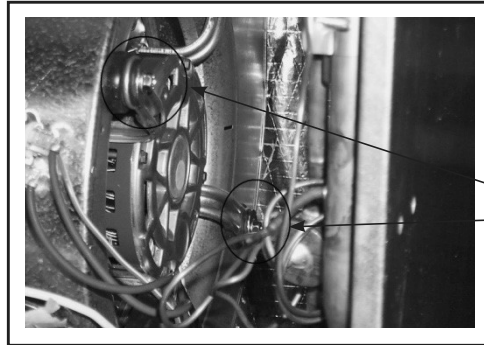

Remove 4 Blower Screws

11. Remove the motor assembly from the blower housing by sliding the motor shaft out of the blower hub.

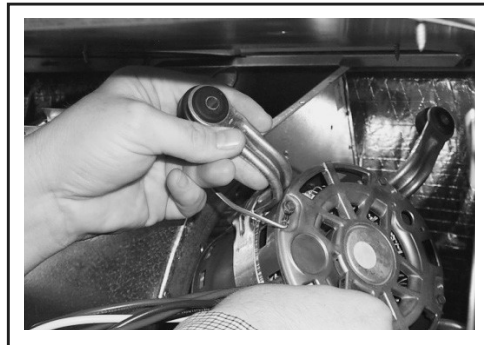

12. Remove the motor assembly from the air handler.

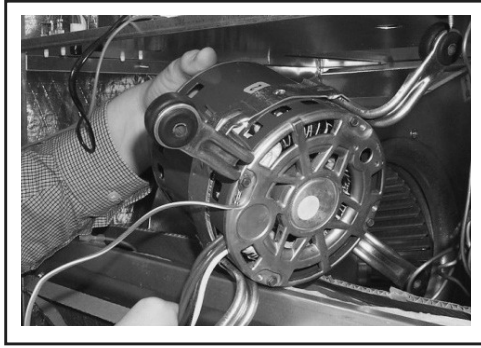

7.16.4 MOTOR REPLACEMENT

With the blower assembly removed, the indoor blower motor can be removed and replaced using the following procedure:

1. Remove motor leads from the motor capacitor control and blower control, or motor terminals.
2. Loosen the set screw holding blower wheel onto the motor shaft. The shaft extends through blower hub so that a wrench can be used on the extended shaft to break the shaft loose if necessary. Be careful not to damage shaft. A wheel puller can be used on the groove in the blower hub if necessary.
3. Remove 4 screws holding the motor mounts to the blower side and remove motor mount assembly from blower assembly.
4. Remove the screw on the belly band strap around the motor shell and remove the 4 mounts from motor.
5. Install (four) motor mounts and the belly band strap on the new motor using the screws removed in the previous step.
6. Insert the motor shaft through the hub in blower wheel and orient motor to original position with motor leads and motor label facing the front of blower (control area).
7. Reassemble 4 screws through motor mounts into blower side. Do not over torque screws.
8. Turn motor shaft so that flat on shaft is located under blower wheel setscrew, and blower wheel is centered in blower housing with the same distance on each side between the inlet orifice and outside of blower wheel. Tighten setscrew on motor shaft. Turn wheel by hand to make sure it runs true without hitting blower sides.
9. • Reassemble motor wiring to capacitor and blower control, or motor terminals making sure that wires match wiring diagram and are tight and secure.

7.16.5 BLOWER WHEEL REPLACEMENT

With the blower assembly removed and the motor assembly removed (see above instructions), remove the screws holding the blower wrap (cutoff) to the blower sides.

1. With wrap (cutoff) screws removed, cut off end of blower wrap will spring up. Lifting wrap blower wheel is removed through the discharge opening in the blower housing.
2. To replace, make sure wheel is oriented properly with hub to the opposite side from the motor. Lift blower wrap and insert blower wheel through discharge opening in the blower housing.
3. Hold blower wrap down into position and replace screws holding blower wrap to blower sides.
4. See motor replacement and blower assembly instructions for remaining assembly procedure.

7.17 REPLACEMENT PARTS

Any replacement part used to replace parts originally supplied on equipment must be the same as or an approved alternate to the original part supplied. The manufacturer will not be responsible for replacement parts not designed to physically fit or operate within the design parameters the original parts were selected for.

These parts include but are not limited to: Circuit breakers, heater controls, heater limit controls, heater elements, motor, motor capacitor, blower relay, control transformer, blower wheel, filter, indoor coil and sheet metal parts.

When ordering replacement parts, it is necessary to order by part number and include with the order the complete model number and serial number from the unit data plate. (See parts list for unit component part numbers).

8.0 DIAGNOSTICS

Problem	Possible Cause (Suggested Fix)
Blower motor will not operate	<ul style="list-style-type: none"> • Failed run capacitor on (-)F1PY (replace) • Failed motor (replace) • Failed motor control module on (-)F2TY (replace module) • Blown 3A fuse on blower control (check for control circuit short, replace fuse) • Loose wiring connection or broken wire (check connections and wiring) • Failed transformer (replace) • Failed blower control (replace) • Disconnect breaker is turned off or has tripped due to over current or shorted circuit (check for shorts, reset breaker)
Excessive vibration	<ul style="list-style-type: none"> • Blower wheel out of balance (replace or clean blower wheel)
Water overflowing drain pan	<ul style="list-style-type: none"> • Plugged drain (clear drain) • Unit not level (level unit)
Electric heater not heating properly or not heating at all, but blower motor is operating	<ul style="list-style-type: none"> • Overflow temperature limit has tripped (check for low air-flow) • Over temperature limit has failed (replace) • Sequencer or contactor has failed (replace) • One or more heating elements have burned out (replace)
Coil is frozen up	<ul style="list-style-type: none"> • System low on refrigerant charge (check for leaks and adjust charge) • Dirty return air filter (replace filter) • Inadequate air-flow due to incorrect blower motor speed selected (select higher speed) or excessively restrictive duct system (correct duct system)
Excessive air-flow	<ul style="list-style-type: none"> • Incorrect blower motor speed selected (select lower speed)
Water blow off from coil	<ul style="list-style-type: none"> • Excessive air-flow (selected lower blower motor speed) • Contaminants on coil fins (clean oil) • Damaged coil fins or replace coil)
TXV not controlling properly	<ul style="list-style-type: none"> • TXV bulb not positioned correctly or clamp not tight (Check position of TXV sensing bulb and tightness of clamp) • Failed TXV (replace) • Plugged TXV inlet screen (clean or replace screen or replace TXV)
Blower Constantly Running	<ul style="list-style-type: none"> • A2L Sensor Failure (Replace RDS if necessary)

9.0 WIRING DIAGRAMS

9.1 WIRING DIAGRAM (-)F1PY (3-5kW ELECTRIC HEAT)

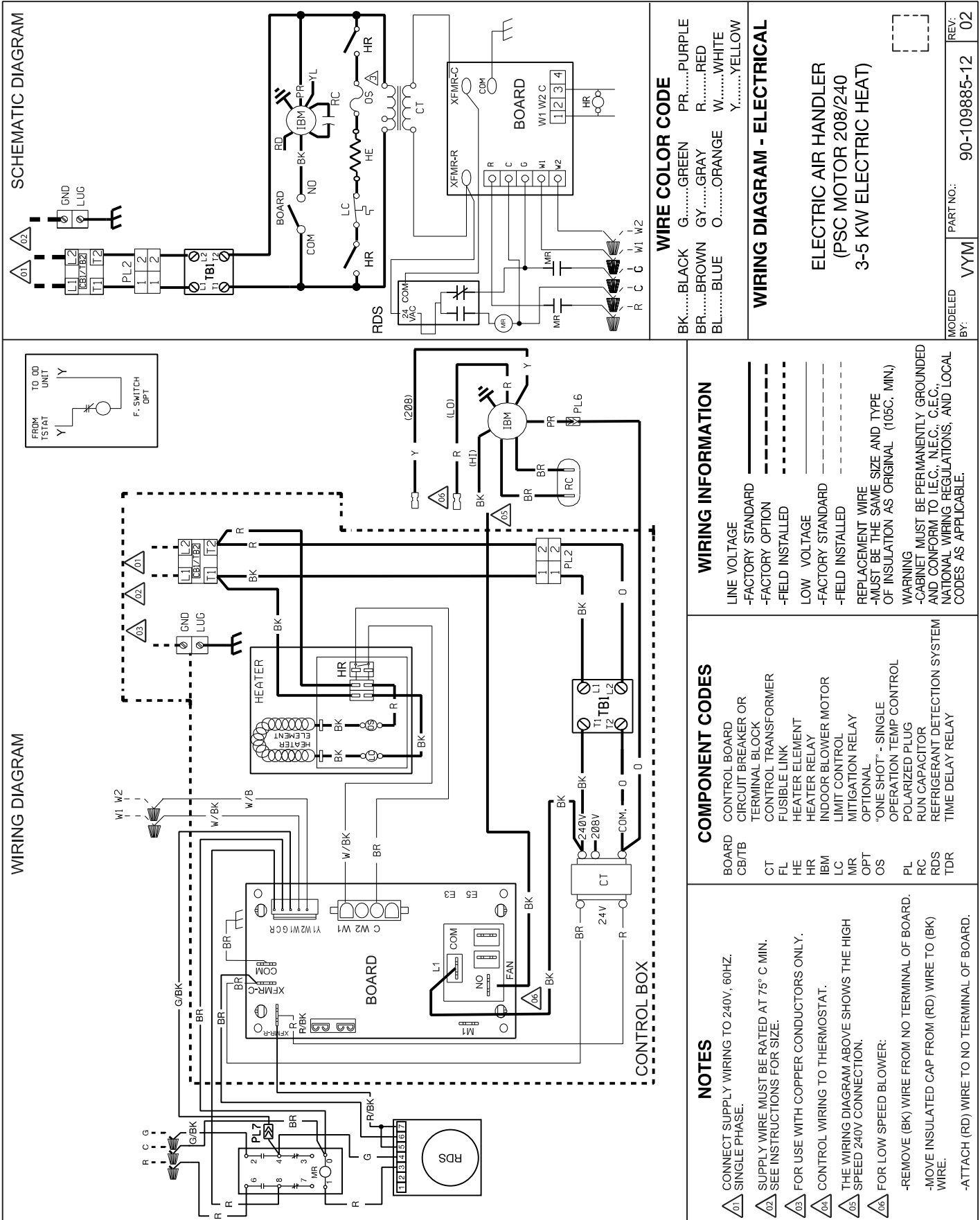

9.2 WIRING DIAGRAM (-)F1PY (8-10kW ELECTRIC HEAT)

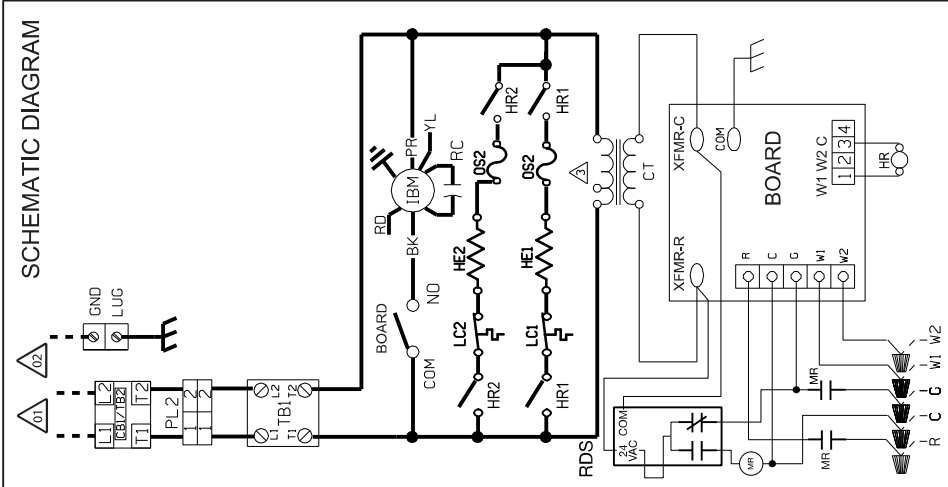

WIRE COLOR CODE

BK.....BLACK G.....GREEN PR.....PURPLE
 BR.....BROWN GY.....GRAY R.....RED
 BL.....BLUE O.....ORANGE W.....WHITE
 Y.....YELLOW

WIRING DIAGRAM - ELECTRICAL

ELECTRIC AIR HANDLER
 (PSC MOTOR 208/240V
 8-10 KW ELECTRIC HEAT)

MODELED BY: VYM PART NO.: 90-109885-13 REV: 02

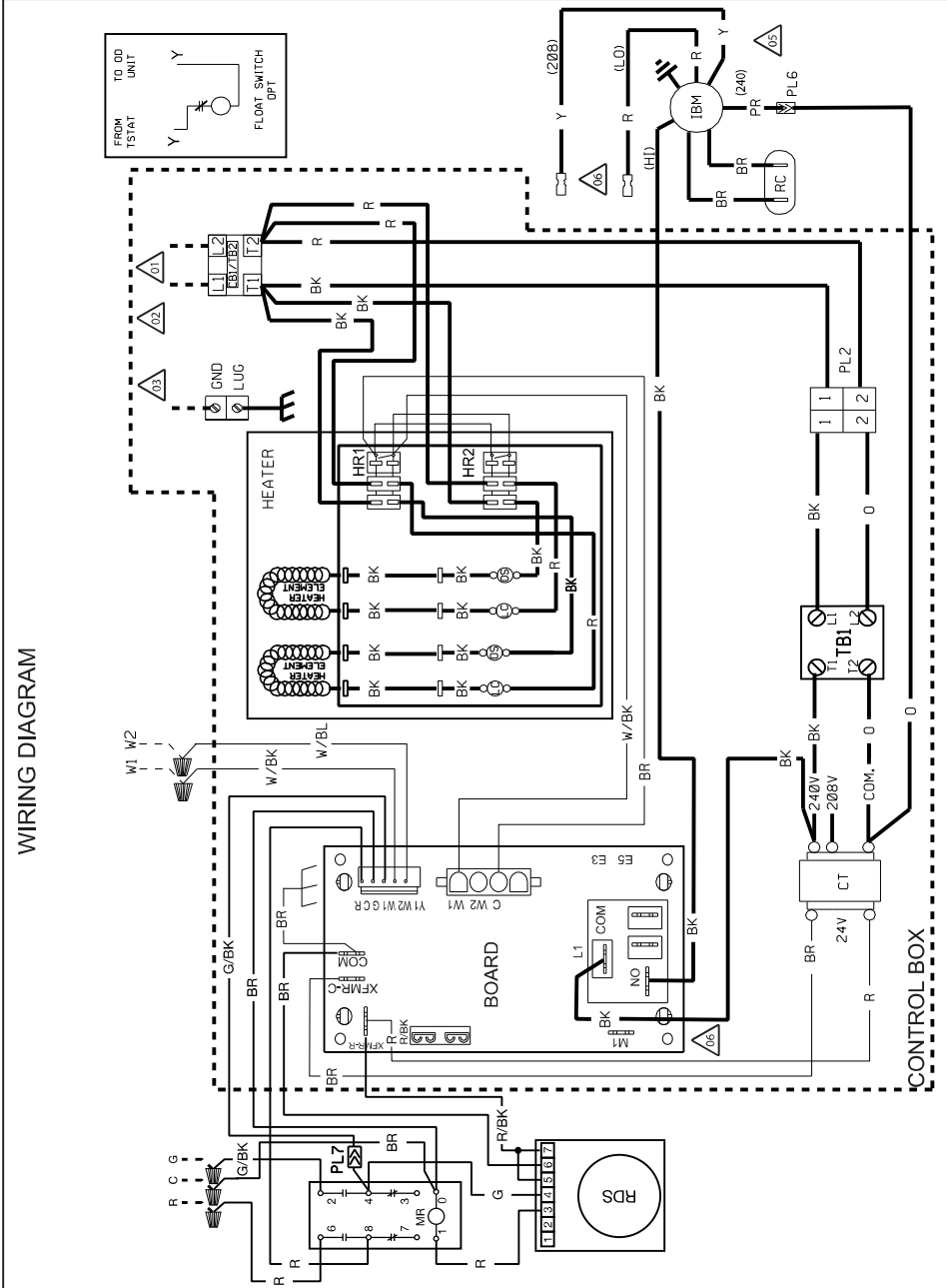

WIRING INFORMATION

LINE VOLTAGE _____
 -FACTORY STANDARD
 -FACTORY OPTION -----
 -FIELD INSTALLED - - - - -
 LOW VOLTAGE _____
 -FACTORY STANDARD -----
 -FIELD INSTALLED - - - - -

REPLACEMENT WIRE
 -MUST BE THE SAME SIZE AND TYPE
 OF INSULATION AS ORIGINAL (105C. MIN.)

WARNING
 -CABINET MUST BE PERMANENTLY GROUNDED
 AND CONFORM TO I.E.C., N.E.C., C.E.C.,
 NATIONAL WIRING REGULATIONS, AND LOCAL
 CODES AS APPLICABLE.

COMPONENT CODES

BOARD CONTROL BOARD
 CB/TB CIRCUIT BREAKER OR TERMINAL BLOCK
 CT CONTROL TRANSFORMER
 FL FUSIBLE LINK
 HE HEATER ELEMENT
 HR HEATER RELAY
 IBM INDOOR BLOWER MOTOR
 LC LIMIT CONTROL
 MR MITIGATION RELAY
 OPT OPTIONAL
 "ONE SHOT" - SINGLE OPERATION TEMP CONTROL
 PL POLARIZED PLUG
 RC RUN CAPACITOR
 RDS REFRIGERANT DETECTION SYSTEM
 TDR TIME DELAY RELAY

NOTES

△01 CONNECT SUPPLY WIRING TO 240V, 60HZ. SINGLE PHASE.
 △02 SUPPLY WIRE MUST BE RATED AT 75° C MIN. SEE INSTRUCTIONS FOR SIZE.
 △03 FOR USE WITH COPPER CONDUCTORS ONLY.
 △04 CONTROL WIRING TO THERMOSTAT.
 △05 THE WIRING DIAGRAM ABOVE SHOWS THE HIGH SPEED 240V CONNECTION.
 △06 FOR LOW SPEED BLOWER:
 -REMOVE (BK) WIRE FROM NO TERMINAL OF BOARD.
 -MOVE INSULATED CAP FROM (RD) WIRE TO (BK) WIRE.
 -ATTACH (RD) WIRE TO NO TERMINAL OF BOARD.

9.3 WIRING DIAGRAM (-)F2TY (3-5kW ELECTRIC HEAT)

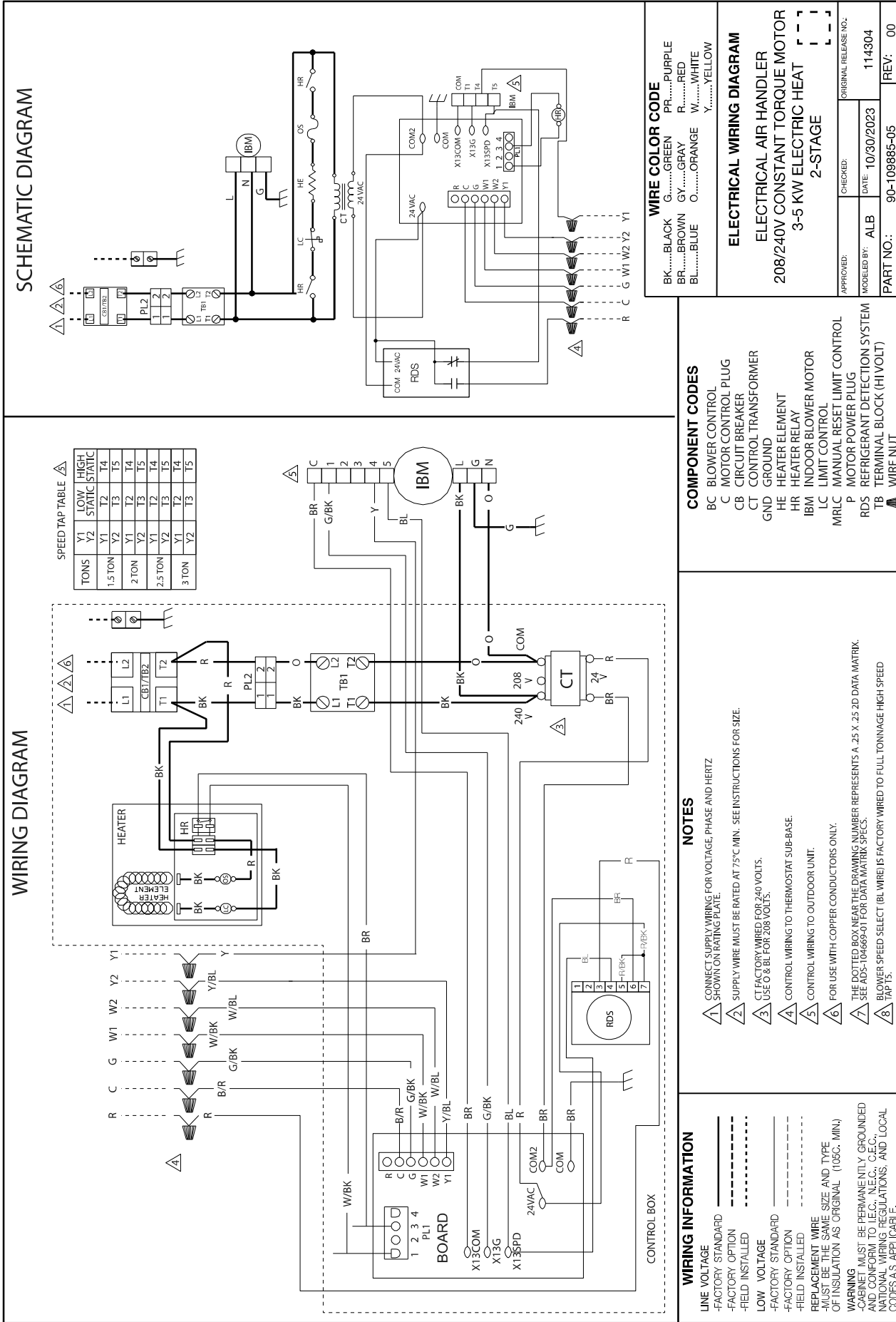

9.5 WIRING DIAGRAM (-)F2TY (230V X-13 MOTOR 2-STAGE)

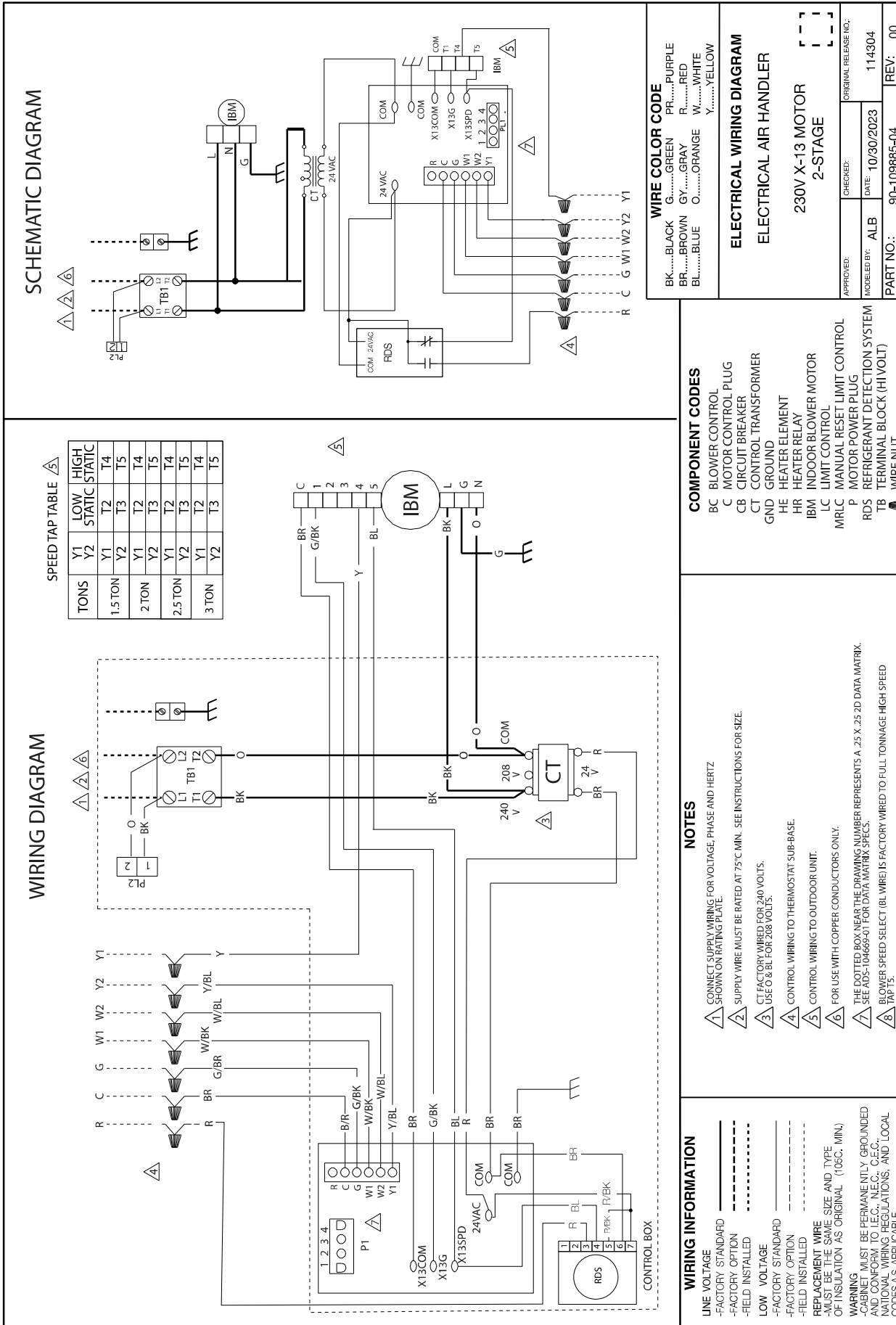

9.6 WIRING DIAGRAM (115V X-13 MOTOR)

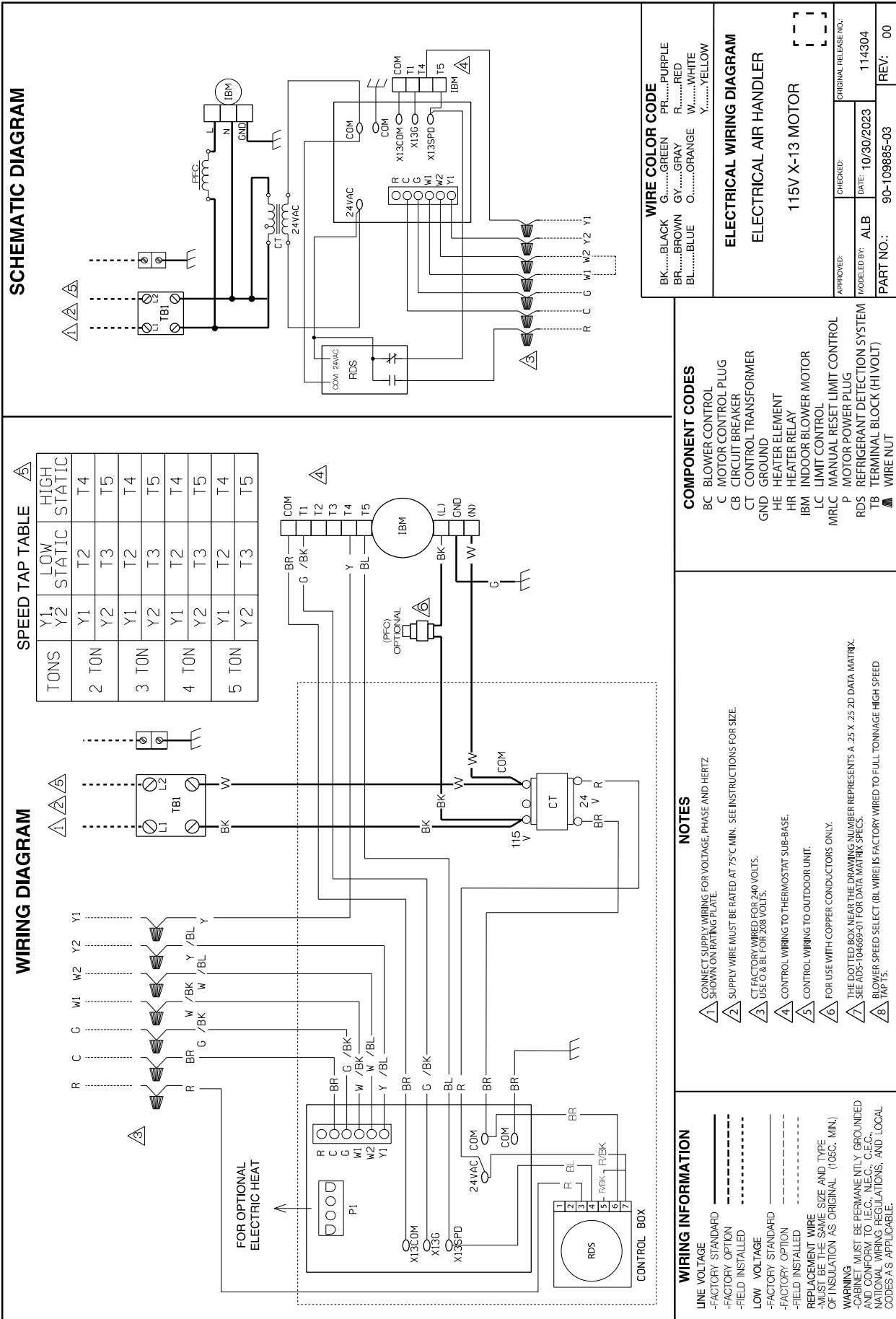

9.7 WIRING DIAGRAM (PSC MOTOR 115 VOLT)

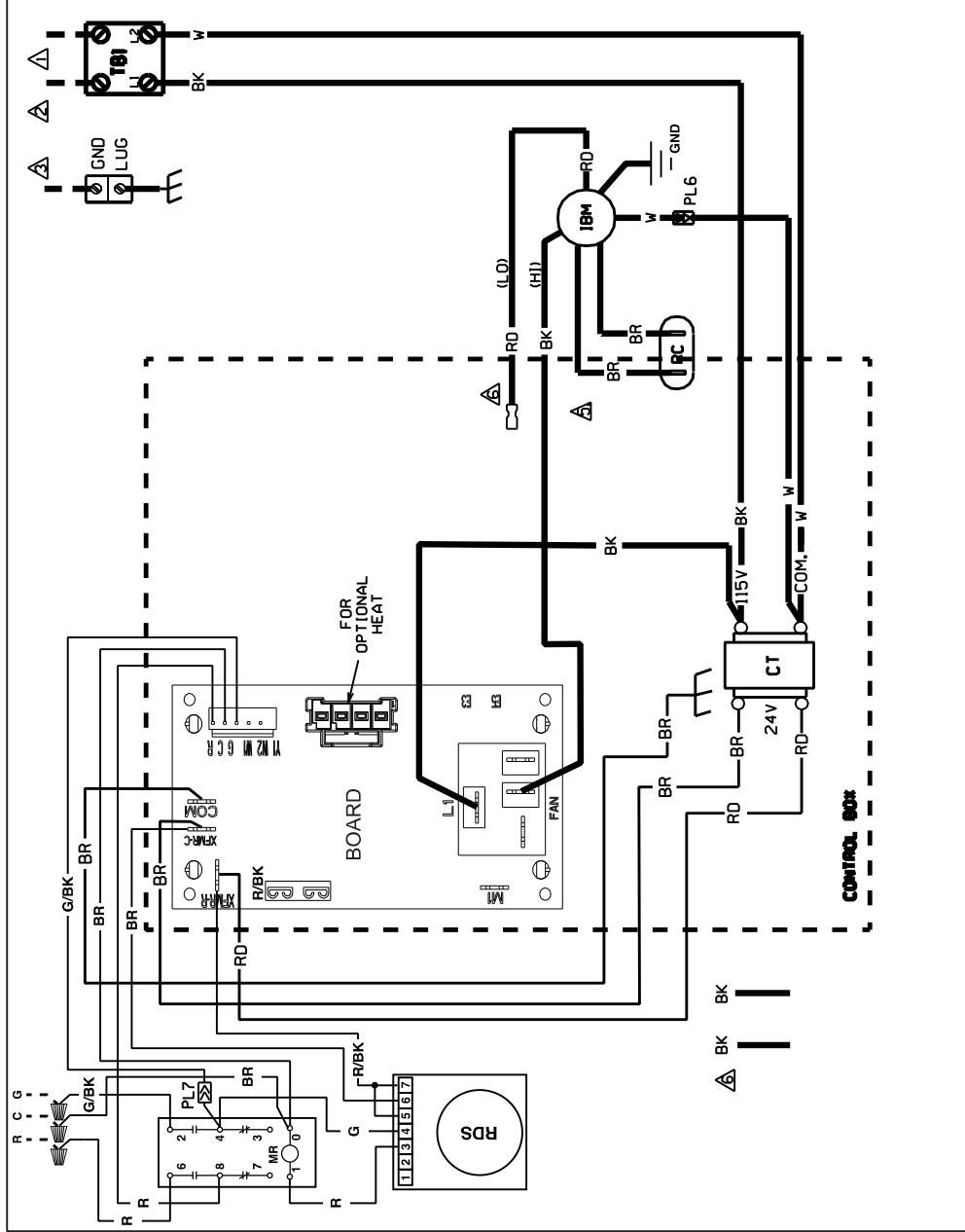
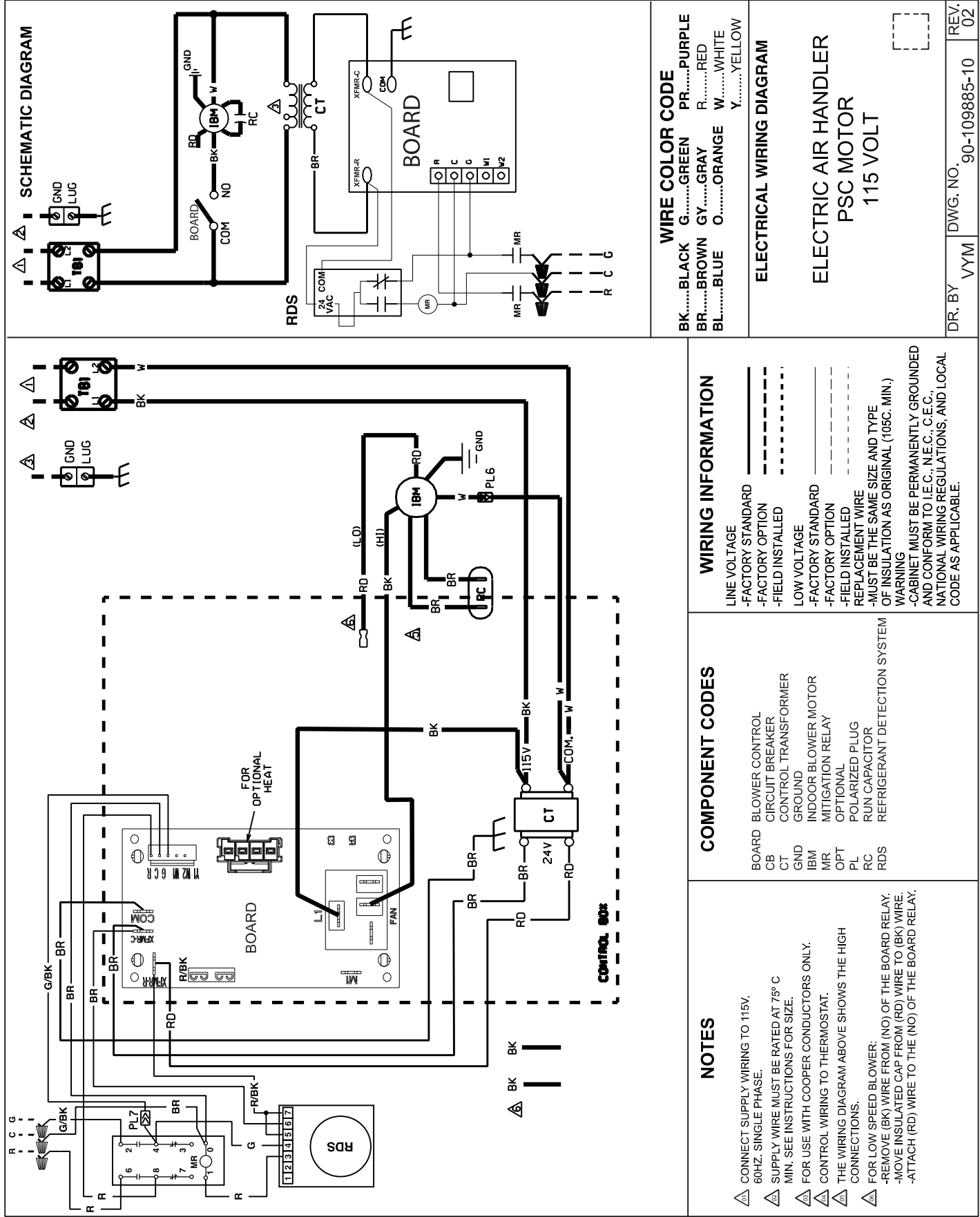

9.8 WIRING DIAGRAM (PSC MOTOR 208/240 VOLT)

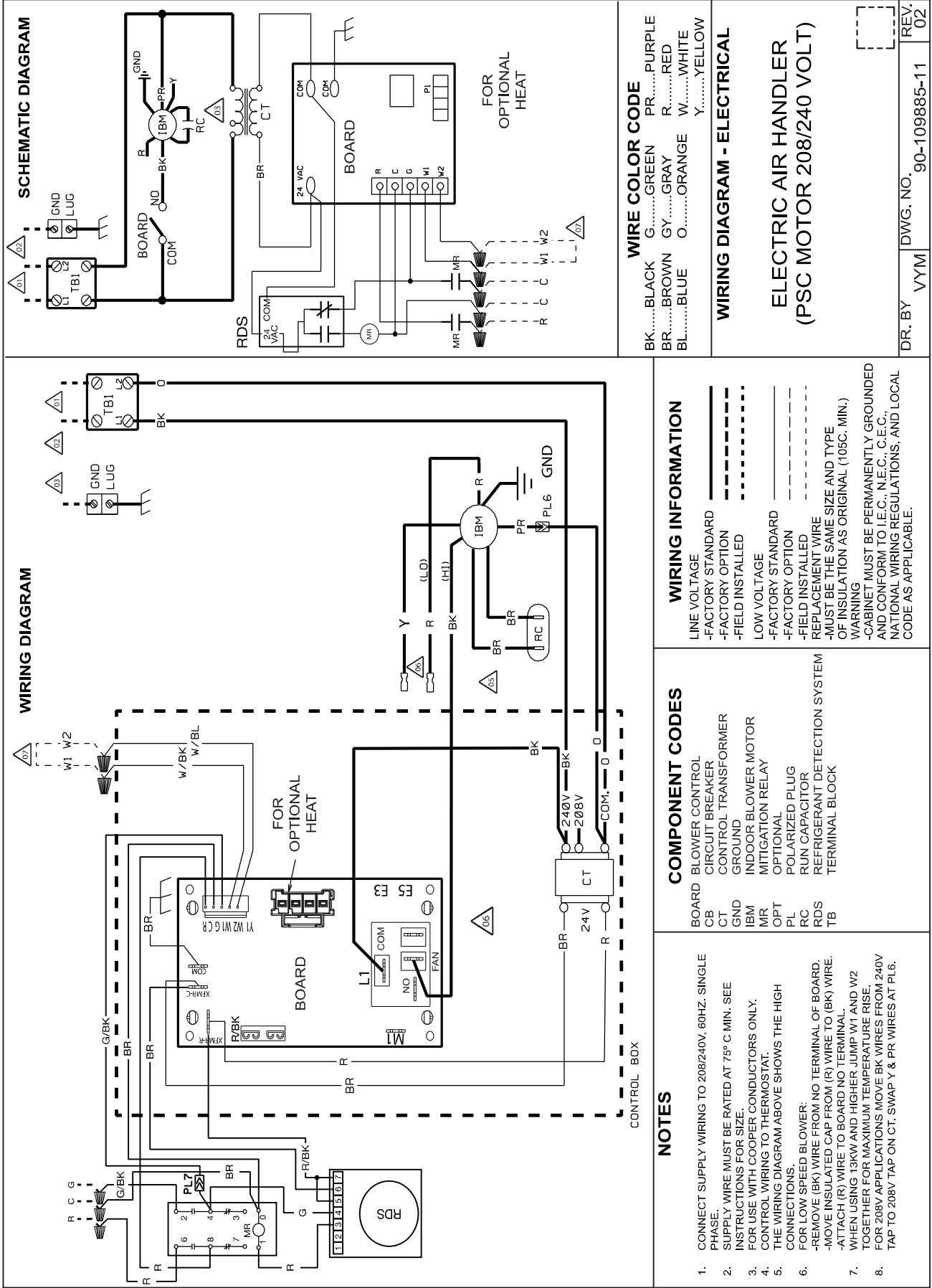

WIRING DIAGRAM

SCHEMATIC DIAGRAM

WIRING INFORMATION

- LINE VOLTAGE
- FACTORY STANDARD
- FACTORY OPTION
- FIELD INSTALLED
- LOW VOLTAGE
- FACTORY STANDARD
- FACTORY OPTION
- FIELD INSTALLED
- REPLACEMENT WIRE
- MUST BE THE SAME SIZE AND TYPE OF INSULATION AS ORIGINAL (105C. MIN.)
- WARNING
- CABINET MUST BE PERMANENTLY GROUNDED AND CONFORM TO I.E.C., N.E.C., C.E.C., NATIONAL WIRING REGULATIONS, AND LOCAL CODE AS APPLICABLE.

COMPONENT CODES

- BOARD BLOWER CONTROL
- CB CIRCUIT BREAKER
- CT CONTROL TRANSFORMER
- GND GROUND
- IBM INDOOR BLOWER MOTOR
- MR MITIGATION RELAY
- OPT OPTIONAL
- PL POLARIZED PLUG
- RUN RUN CAPACITOR
- RDS REFRIGERANT DETECTION SYSTEM
- TB TERMINAL BLOCK

NOTES

1. CONNECT SUPPLY WIRING TO 208/240V, 60HZ. SINGLE PHASE.
2. SUPPLY WIRE MUST BE RATED AT 75° C MIN. SEE INSTRUCTIONS FOR SIZE.
3. FOR USE WITH COOPER CONDUCTORS ONLY.
4. CONTROL WIRING TO THERMOSTAT.
5. THE WIRING DIAGRAM ABOVE SHOWS THE HIGH CONNECTIONS.
6. FOR LOW SPEED BLOWER:
 - REMOVE (BK) WIRE FROM NO TERMINAL OF BOARD.
 - MOVE INSULATED CAP FROM (R) WIRE TO (BK) WIRE.
 - ATTACH (R) WIRE TO BOARD NO TERMINAL.
7. TOGETHER FOR MAXIMUM TEMPERATURE RISE.
8. FOR 208V APPLICATIONS MOVE BK WIRES FROM 240V TAP TO 208V TAP ON CT. SWAP Y & PR WIRES AT PL6.

WIRE COLOR CODE

- BK.....BLACK G.....GREEN PR.....PURPLE
- BR.....BROWN GY.....GRAY R.....RED
- BL.....BLUE O.....ORANGE W.....WHITE
- Y.....YELLOW

WIRING DIAGRAM - ELECTRICAL

ELECTRIC AIR HANDLER (PSC MOTOR 208/240 VOLT)

DR. BY VYM DWG. NO. 90-109885-11 REV. 02