



Commercial Split Classic® Series Air Conditioner



15, 20 Ton

6.5, 7.5, 10 Ton

10, 12.5 Ton

RACY Series

Cooling Efficiencies up to: 11.2 EER/14.8 IEER
Nominal Sizes: 6.5, 7.5, 10, 12.5, 15 & 20 Tons
[22.9, 26.4, 35.2, 44.0, 52.7 & 70.3 kW]
Cooling Capacities: 72.2k Btu/h to 240.0k Btu/h
Refrigerant Type: R-454B
Designed for use with matching RHCYA models



TABLE OF CONTENTS

Unit Features and Benefits	3-4
Model Number Identification	5
Selection Procedures	6
General Data	7-13
Electrical & Physical Data.....	14-15
A2L Refrigerant Installation Safety Data	16-18
Cooling Performance Data.....	19-24
Dimensional Data	25-27
Piping Recommendation	28-29
Guide Specifications	30-31
Limited Warranty	32



RACY STANDARD FEATURES INCLUDE:

- Factory charged with nitrogen for shipping
- Ready to be charged with R-454B Low GWP refrigerant in the field after installation
- Wired and run tested
- Scroll compressors with internal line break overload and high pressure protection
- High and Low Pressure switches provide additional system protection
- Forkable base rails on 10 (two fan), 12.5, 15, and 20 Ton for easy handling and lifting
- Cooling operation up to 125°F ambient
- Tube and Fin condenser and evaporator coils
- Single-piece control door
- 6.5, 7.5 and 10 Ton includes a single 2-Stage scroll compressor
- 12.5, 15, and 20 Ton includes a tandem scroll compressor configuration

ACCESSORIES

ACCESSORY DESCRIPTION	MODEL NUMBER	SIZE USED ON
Low Ambient Control	RXAD-A08	078, 090, 119, 120, 150, 180, 240

WHY USE AN AIR COOLED CONDENSING UNIT?

- The size ranges offered by Rheem® allow you to mix or match components to meet actual job requirements, thus eliminating the need to use oversized or undersized equipment. Equipment sized to meet the actual load will provide better operating economy, better humidity control, and longer equipment life.
- With an air cooled system, you have no water or sewer connections to make, and no troublesome and costly water treatment problems.
- Since the AC condensing unit is located outside the building, and the low profile air handling unit can be installed in the drop ceiling or in the conditioned space, you will not need a separate equipment room which takes up valuable building space.
- Remote mounting of the already quiet AC condensing unit keeps the compressor and condenser fan noise outside, and the vertical discharge fans carry the sound up and away from the surrounding area.
- Because of the simple design of the Rheem remote AC condensing unit, installation is quick and simple, and very little maintenance is required.



Designing for Sustainability with Low GWP: For 2025, the Environmental Protection Agency (EPA) has set a global warming potential (GWP) limit of 700 for refrigerant used in heating and cooling systems. This new requirement will result in a 78%¹ lower GWP than previous-generation refrigerants — with only minimal changes to system installation. For us, this is another step toward our continued sustainability goal of reducing greenhouse gas emissions, while still delivering an exceptional level of energy efficient, dependable comfort.

¹When comparing the GWP of R-454B to R-410A refrigerant.

GENERAL INSTALLATION

The Remote AC Condensing unit must be installed outdoors. It should be located as near as possible to the indoor section to keep connecting refrigerant tubing lengths to a minimum. The unit must be installed to allow a free air flow to the outdoor coils.

If several units are installed adjacent to each other, care must be taken to avoid recirculation of air from one remote condenser to another. In all installations, adequate space must be provided for installation and servicing.

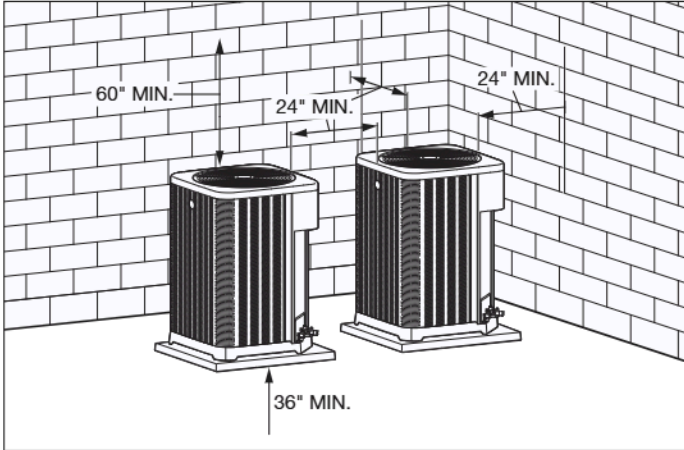

The outdoor unit must not be connected to any duct work. Do not locate unit under a roof drip; if necessary, install gutters, etc., to prevent water run-off from hitting the unit. To prevent air recirculation, it is recommended that the unit not be installed under an overhang, but if necessary allow a minimum of 60 inches [1524 mm] above the unit for air discharge.

[] Designates Metric Conversions

SLAB INSTALLATION

Remote Condensing units should be set on a solid level foundation. When installed at ground level, the unit should be placed on a 6 inch [152.4 mm] cement slab. If the pad is formed at the installation site, do not pour the pad tight against the structure, otherwise vibration will be transmitted from the unit through the pad.

ROOFTOP INSTALLATION

If rooftop installation is required, make certain that the building construction is adequate for the weight of the unit (refer to physical data chart). Before placing the unit on the roof, make certain that the nylon rigging slings are of sufficient length to maintain equilibrium of the unit when lifting. Under no circumstances should the unit be lifted by only one corner for rooftop installation.

R **A** **C** **Y** **2** **078** **C** **A** **Z**
1 **2** **3** **4** **5** **678** **9** **10** **11**

1—Brand

R = Rheem

2—Unit Type

A = Remote Condensing Unit

3—Cabinet Type

C = Commercial

4—Refrigerant

Y = R-454B

5—Cooling Configuration

2 = 2 Stage Cooling

6,7,8—Capacity

078 = 6.5 Ton

090 = 7.5 Ton

119 = 10 Ton (1 fan)

120 = 10 Ton (2 fan)

150 = 12.5 Ton

180 = 15 Ton

240 = 20 Ton

9—Electrical Designation

C = 208/230 V, 3 PH, 60 Hz

D = 460 V, 3 PH, 60 Hz

Y = 575 V, 3 PH, 60 Hz

10—Minor Series

A = 1st Design

11—Compressor

Z = Scroll Compressor

COMMERCIAL SPLIT AIR CONDITIONER MODEL MATCH-UPS

OUTDOOR UNIT MODEL NUMBER	INDOOR AIR HANDLER MODEL NUMBER
RACY2078	RHCYA2090
RACY2090	RHCYA2090
RACY2119	RHCYA2121
RACY2120	RHCYA2120
RACY2150	RHCYA2150
RACY2180	RHCYA2180
RACY2240	RHCYA2240

SELECTION PROCEDURE

To select an RACY Remote AC Condensing unit to meet a job requirement, follow this procedure:

1. DETERMINE COOLING AND HEATING REQUIREMENTS AND SPECIFIC OPERATING CONDITIONS FROM PLANS AND SPECS.

Example: Total cooling capacity—	84,000 Btu/h [24.61 kW]
Sensible cooling capacity—	68,000 Btu/h [19.92 kW]
Heating capacity—	120,000 Btu/h [35.16 kW]
*Condenser Entering Air—	95°F [35°C] DB
*Evaporator Mixed Air Entering	78°F [26°C] DB; 65°F [18°C] WB
*Indoor Air Flow (vertical)	3000 CFM [1416 L/s]
*External Static Pressure	.5 in. WG
Available Power	240 V, 3 PH

2. SELECT UNIT TO MEET COOLING REQUIREMENTS.

Since total cooling is within the range of a nominal 7.5 ton [26.4 kW] unit, enter cooling performance table at 95°F [35°C] DB condenser inlet air. Interpolate between 63°F [2°C] and 67°F [19°C] to determine total and sensible capacity and power input for 65°F [18°C] WB evapor inlet air at 3200 CFM [1510 L/s] indoor air flow (table basis):

Total Capacity = 85,150 Btu/h [25.0 kW]
Sensible Capacity = 73,850 Btu/h [23.0 kW]
Power Input (Compressor and Cond. Fans) = 6,750 Watts

Use formula in note ① on the cooling performance table to determine sensible capacity at 78°F [26°C] DB evaporator entering air:

$$\text{Sensible Capacity} = 67,250 \text{ Btu/h [19.7 kW]}$$

3. CORRECT CAPACITIES OF STEP 2 FOR ACTUAL AIR FLOW.

Select factors from airflow correction table at 3000 CFM [1416 L/s] and apply to data obtained in step 2 to obtain gross capacity:

Total Capacity = 85,150 x .99 = 84,299 Btu/h [24.7 kW]
Sensible Capacity = 73,850 x .97 = 71,634 Btu/h [21.0 kW]
Power Input = 6,750 x 1.00 = 6,750 Watts

These are Gross Capacities, not corrected for blower motor heat or power.

4. DETERMINE BLOWER SPEED AND WATTS TO MEET SYSTEM DESIGN.

In the “Commercial Air Handler Specification Sheet” follow the bold line example on the “Blower Performance Curve – 10 ton (wet coil)”. Enter the graph at 3000 CFM [1416 L/s]. Determine which “number of turns” line is closest to the intersection of 0.5 IN [.12 kPa] static and 3000 CFM [1416 L/s]. In this case 4 turns is the closest. Continue following the 3000 CFM line to the next intersection of 4 turns. From this intersection draw a line to the right to determine the watts.

$$\text{WATTS} = 950$$

5. CALCULATE INDOOR BLOWER Btu/h HEAT EFFECT FROM MOTOR WATTS, STEP 4.

$$\text{HEAT} = 950 \times 3.412 = 3,240 \text{ Btu/h}$$

6. CALCULATE NET COOLING CAPACITIES, EQUAL TO GROSS CAPACITY, STEP 3, MINUS INDOOR BLOWER MOTOR HEAT.

Net Total Capacity = 84,299 – 3,240 = 81,059 Btu/h [23.76 kW] Net
Net Sensible Capacity = 71,634 – 3,240 = 68,394 Btu/h [20.00 kW]

7. CALCULATE UNIT INPUT AND JOB EER.

$$\begin{aligned} \text{Total Power Input} &= 6,750 \text{ (step 3)} + 950 \text{ (step 4)} = 7,700 \text{ Watts} \\ \text{EER} &= \frac{\text{Net Total Btu/h [kW] (step 6)}}{\text{Power Input, Watts (above)}} = \frac{81,059}{7,700} = 10.5 \end{aligned}$$

8. SELECT UNIT HEATING CAPACITY.

In the “Commercial Air Handler Specification Sheet” turn to the “electrical heater kit characteristics table,” find a heater kit that is compatible and has minimum of 120,000 Btu/h. The RXHE-DE020CA [20 kW] has a capacity of 114,000 Btu/h at 208/230 V.

*NOTE: These operating conditions are typical of a commercial application in a 95°F/79°F [35°C/26°C] design area with indoor design of 76°F [24°C] DB and 50% RH and 10% ventilation air, with the unit mounted and centered on the zone it conditions by ducts.

[] Designates Metric Conversions

GENERAL DATA—RACY2 MODELS—6.5 TONS [22.9 kW]

Model RACY2 Series	078CAZ	078DAZ	078YAZ
Cooling Performance^A			CONTINUED →
Gross Cooling Capacity Btu/h [kW]	78,000 [22.9]	78,000 [22.9]	78,000 [22.9]
EER	11.2	11.2	11.2
IEER ^B	14.8	14.8	14.8
Nominal CFM/AHRI Rated CFM [L/s]	2,600/2,580 [1,227/1,218]	2,600/2,580 [1,227/1,218]	2,600/2,580 [1,227/1,218]
AHRI Net Cooling Capacity Btu/h [kW]	72,200 [21.2]	72,200 [21.2]	72,200 [21.2]
Net Sensible Capacity Btu/h [kW]	53,500 [15.7]	53,500 [15.7]	53,500 [15.7]
Net Latent Capacity Btu/h [kW]	18,700 [5.5]	18,700 [5.5]	18,700 [5.5]
Compressor			
No./Type	1/Scroll	1/Scroll	1/Scroll
Outdoor Sound Rating (dB)^C	86	86	86
Outdoor Coil - Fin Type	Louvered	Louvered	Louvered
Tube Type	Rifled	Rifled	Rifled
Tube Diameter	0.375	0.375	0.375
Outer Face Area sq. ft. [sq. m]	31.8 [3.0]	31.8 [3.0]	31.8 [3.0]
Inner Face Area sq. ft. [sq. m]	29.6 [2.7]	29.6 [2.7]	29.6 [2.7]
Rows/FPI [FPCm]	2 / 22 [9]	2 / 22 [9]	2 / 22 [9]
Outdoor Fan - Type	Propeller	Propeller	Propeller
No. Blades/Diameter in. [mm]	4/26 [660]	4/26 [660]	4/26 [660]
Drive Type/No. Speeds	ECM/1	ECM/1	PSC/1
CFM [L/s]	5,700 [2,690]	5,700 [2,690]	5,700 [2,690]
No. Motors/HP	1 at 1/2HP	1 at 3/4HP	1 at 1/2HP
Motor RPM	1,100	1,100	1,100
Refrigerant Charge Oz. [g]	338 [9,582]	338 [9,582]	338 [9,582]
Weights			
Net Weight lbs. [kg]	383 [174]	383 [174]	383 [174]
Ship Weight lbs. [kg]	403 [183]	403 [183]	403 [183]

NOTES:

A. Cooling Performance is rated at 95°F ambient, 80°F entering dry bulb, 67°F entering wet bulb. Gross capacity does not include the effect of fan motor heat. AHRI capacity is net and includes the effect of fan motor heat. Units are suitable for operation to 20% of nominal cfm. Units are certified in accordance with the Unitary Air Conditioner Equipment certification program, which is based on AHRI Standard 340/360.

B. EER and Integrated Efficiency Ratio (IEER) is rated at AHRI conditions in accordance with AHRI Standard 340/360.

C. Outdoor Sound Rating shown is tested in accordance with AHRI Standard 270.

[] Designates Metric Conversions

GENERAL DATA—RACY2 MODELS—7.5 TONS [26.4 kW]

Model RACY2 Series	090CAZ	090DAZ	090YAZ
Cooling Performance^A			CONTINUED →
Gross Cooling Capacity Btu/h [kW]	90,000 [26.4]	90,000 [26.4]	90,000 [26.4]
EER	11.2	11.2	11.2
IEER ^B	14.8	14.8	14.8
Nominal CFM/AHRI Rated CFM [L/s]	2,600/2,580 [1,227/1,218]	2,600/2,580 [1,227/1,218]	2,600/2,580 [1,227/1,218]
AHRI Net Cooling Capacity Btu/h [kW]	85,500 [25.1]	85,500 [25.1]	85,500 [25.1]
Net Sensible Capacity Btu/h [kW]	61,500 [18.0]	61,500 [18.0]	61,500 [18.0]
Net Latent Capacity Btu/h [kW]	24,000 [7.0]	24,000 [7.0]	24,000 [7.0]
Compressor			
No./Type	1/Scroll	1/Scroll	1/Scroll
Outdoor Sound Rating (dB)^C	86	86	86
Outdoor Coil - Fin Type	Louvered	Louvered	Louvered
Tube Type	Rifled	Rifled	Rifled
Tube Diameter	0.375	0.375	0.375
Outer Face Area sq. ft. [sq. m]	31.8 [3.0]	31.8 [3.0]	31.8 [3.0]
Inner Face Area sq. ft. [sq. m]	29.6 [2.7]	29.6 [2.7]	29.6 [2.7]
Rows/FPI [FPcm]	2 / 22 [9]	2 / 22 [9]	2 / 22 [9]
Outdoor Fan - Type	Propeller	Propeller	Propeller
No. Blades/Diameter in. [mm]	4/26	4/26	4/26
Drive Type/No. Speeds	ECM/1	ECM/1	PSC/1
CFM [L/s]	5,700 [2,690]	5,700 [2,690]	5,700 [2,690]
No. Motors/HP	1 at 1/2HP	1 at 3/4HP	1 at 1/2HP
Motor RPM	1,100	1,100	1,100
Refrigerant Charge Oz. [g]	338 [9,582]	338 [9,582]	338 [9,582]
Weights			
Net Weight lbs. [kg]	383 [174]	383 [174]	383 [174]
Ship Weight lbs. [kg]	403 [183]	403 [183]	403 [183]

NOTES:

A. Cooling Performance is rated at 95°F ambient, 80°F entering dry bulb, 67°F entering wet bulb. Gross capacity does not include the effect of fan motor heat. AHRI capacity is net and includes the effect of fan motor heat. Units are suitable for operation to 20% of nominal cfm. Units are certified in accordance with the Unitary Air Conditioner Equipment certification program, which is based on AHRI Standard 340/360.

B. EER and Integrated Efficiency Ratio (IEER) is rated at AHRI conditions in accordance with AHRI Standard 340/360.

C. Outdoor Sound Rating shown is tested in accordance with AHRI Standard 270.

[] Designates Metric Conversions

GENERAL DATA—RACY2 MODELS—10 TONS [35.2 kW]

Model RACY2 Series	119CAZ	119DAZ	120CAZ	120DAZ	120YAZ
Cooling Performance^A					CONTINUED →
Gross Cooling Capacity Btu/h [kW]	120,000 [35.2]	120,000 [35.2]	120,000 [35.2]	120,000 [35.2]	120,000 [35.2]
EER	11.2	11.2	11.2	11.2	11.2
IEER ^B	14.8	14.8	14.8	14.8	14.8
Nominal CFM/AHRI Rated CFM [L/s]	4,000/3,900 [1,888/1,841]	4,000/3,900 [1,888/1,841]	4,000/3,900 [1,888/1,841]	4,000/3,900 [1,888/1,841]	4,000/3,900 [1,888/1,841]
AHRI Net Cooling Capacity Btu/h [kW]	112,000 [32.8]	112,000 [32.8]	114,000 [33.4]	114,000 [33.4]	114,000 [33.4]
Net Sensible Capacity Btu/h [kW]	86,000 [25.2]	86,000 [25.2]	86,000 [25.2]	86,000 [25.2]	86,000 [25.2]
Net Latent Capacity Btu/h [kW]	26,000 [7.6]	26,000 [7.6]	28,000 [8.2]	28,000 [8.2]	28,000 [8.2]
Compressor					
No./Type	1/Scroll	1/Scroll	1/Scroll	1/Scroll	1/Scroll
Outdoor Sound Rating (dB)^C	86	86	88	88	88
Outdoor Coil - Fin Type	Louvered	Louvered	Louvered	Louvered	Louvered
Tube Type	Rifled	Rifled	Rifled	Rifled	Rifled
Tube Diameter	0.375	0.375	0.375	0.375	0.375
Outer Face Area sq. ft. [sq. m]	31.8 [3.0]	31.8 [3.0]	16.4 [1.5]	16.4 [1.5]	16.4 [1.5]
Inner Face Area sq. ft. [sq. m]	29.6 [2.7]	29.6 [2.7]	16.4 [1.5]	16.4 [1.5]	16.4 [1.5]
Rows/FPI [FPcm]	2 / 22 [9]	2 / 22 [9]	2 / 22 [9]	2 / 22 [9]	2 / 22 [9]
Outdoor Fan - Type	Propeller	Propeller	Propeller	Propeller	Propeller
No. Blades/Diameter in. [mm]	4/26 [660]	4/26 [660]	4/26 [660]	4/26 [660]	4/26 [660]
Drive Type/No. Speeds	ECM/1	ECM/1	ECM/2	ECM/2	PSC/2
CFM [L/s]	5,700 [2,690]	5,700 [2,690]	11,400 [5380]	11,400 [5380]	11,400 [5380]
No. Motors/HP	1 at 1/2HP	1 at 3/4HP	2 at 1/2HP	2 at 3/4HP	2 at 1/2HP
Motor RPM	1,100	1,100	1,100	1,100	1,100
Refrigerant Charge Oz. [g]	338 [9,582]	338 [9,582]	460 [13,041]	460 [13,041]	460 [13,041]
Weights					
Net Weight lbs. [kg]	411 [186]	411 [186]	565 [256]	565 [256]	565 [256]
Ship Weight lbs. [kg]	431 [195]	431 [195]	585 [265]	585 [265]	585 [265]

NOTES:

A. Cooling Performance is rated at 95°F ambient, 80°F entering dry bulb, 67°F entering wet bulb. Gross capacity does not include the effect of fan motor heat. AHRI capacity is net and includes the effect of fan motor heat. Units are suitable for operation to 20% of nominal cfm. Units are certified in accordance with the Unitary Air Conditioner Equipment certification program, which is based on AHRI Standard 340/360.

B. EER and Integrated Efficiency Ratio (IEER) is rated at AHRI conditions in accordance with AHRI Standard 340/360.

C. Outdoor Sound Rating shown is tested in accordance with AHRI Standard 270.

[] Designates Metric Conversions

GENERAL DATA—RACY2 MODELS—12.5 TONS [44.0 kW]

Model RACY2 Series	150CAZ	150DAZ	150YAZ
Cooling Performance^A			CONTINUED →
Gross Cooling Capacity Btu/h [kW]	150,000 [44.0]	150,000 [44.0]	150,000 [44.0]
EER	11.0	11.0	11.0
IEER ^B	14.2	14.2	14.2
Nominal CFM/AHRI Rated CFM [L/s]	4,500/4,350 [2,124/2,053]	4,500/4,350 [2,124/2,053]	4,500/4,350 [2,124/2,053]
AHRI Net Cooling Capacity Btu/h [kW]	142,500 [42.0]	142,500 [42.0]	142,500 [42.0]
Net Sensible Capacity Btu/h [kW]	106,000 [31.1]	106,000 [31.1]	106,000 [31.1]
Net Latent Capacity Btu/h [kW]	36,500 [10.7]	36,500 [10.7]	36,500 [10.7]
Compressor			
No./Type	2/Scroll	2/Scroll	2/Scroll
Outdoor Sound Rating (dB)^C	88	88	88
Outdoor Coil - Fin Type	Louvered	Louvered	Louvered
Tube Type	Rifled	Rifled	Rifled
Tube Diameter	0.375	0.375	0.375
Outer Face Area sq. ft. [sq. m]	16.4 [1.5]	16.4 [1.5]	16.4 [1.5]
Inner Face Area sq. ft. [sq. m]	16.4 [1.5]	16.4 [1.5]	16.4 [1.5]
Rows/FPI [FPcm]	2 / 22 [56]	2 / 22 [56]	2 / 22 [56]
Outdoor Fan - Type	Propeller	Propeller	Propeller
No. Blades/Diameter in. [mm]	4/26 [660]	4/26 [660]	4/26 [660]
Drive Type/No. Speeds	ECM/1	ECM/1	PSC/1
CFM [L/s]	11,400 [5,380]	11,400 [5,380]	11,400 [5,380]
No. Motors/HP	2 at 1/2HP	2 at 3/4HP	2 at 1/2HP
Motor RPM	1,100	1,100	1,100
Refrigerant Charge Oz. [g]	372 [10,546]	372 [10,546]	372 [10,546]
Weights			
Net Weight lbs. [kg]	647 [293]	647 [293]	647 [293]
Ship Weight lbs. [kg]	667 [303]	667 [303]	667 [303]

NOTES:

A. Cooling Performance is rated at 95°F ambient, 80°F entering dry bulb, 67°F entering wet bulb. Gross capacity does not include the effect of fan motor heat. AHRI capacity is net and includes the effect of fan motor heat. Units are suitable for operation to 20% of nominal cfm. Units are certified in accordance with the Unitary Air Conditioner Equipment certification program, which is based on AHRI Standard 340/360.

B. EER and Integrated Efficiency Ratio (IEER) is rated at AHRI conditions in accordance with AHRI Standard 340/360.

C. Outdoor Sound Rating shown is tested in accordance with AHRI Standard 270.

[] Designates Metric Conversions

GENERAL DATA—RACY2 MODELS— 15 TONS [52.8 kW]

Model RACY2 Series	180CAZ	180DAZ	180YAZ
Cooling Performance^A			CONTINUED →
Gross Cooling Capacity Btu/h [kW]	180,000 [52.8]	180,000 [52.8]	180,000 [52.8]
EER	11.0	11.0	11.0
IEER ^B	14.2	14.2	14.2
Nominal CFM/AHRI Rated CFM [L/s]	5,400/5,200 [2,549/2,454]	5,400/5,200 [2,549/2,454]	5,400/5,200 [2,549/2,454]
AHRI Net Cooling Capacity Btu/h [kW]	171,000 [50.1]	171,000 [50.1]	171,000 [50.1]
Net Sensible Capacity Btu/h [kW]	125,000 [36.6]	125,000 [36.6]	125,000 [36.6]
Net Latent Capacity Btu/h [kW]	46,000 [13.5]	46,000 [13.5]	46,000 [13.5]
Compressor			
No./Type	2/Scroll	2/Scroll	2/Scroll
Outdoor Sound Rating (dB)^C	90	90	90
Outdoor Coil - Fin Type	Louvered	Louvered	Louvered
Tube Type	Rifled	Rifled	Rifled
Tube Diameter	0.375	0.375	0.375
Outer Face Area sq. ft. [sq. m]	30.3 [2.8]	30.3 [2.8]	30.3 [2.8]
Inner Face Area sq. ft. [sq. m]	30.3 [2.8]	30.3 [2.8]	30.3 [2.8]
Rows/FPI [FPCm]	3 / 18 [46]	3 / 18 [46]	3 / 18 [46]
Outdoor Fan - Type	Propeller	Propeller	Propeller
No. Blades/Diameter in. [mm]	4/24	4/24	4/24
Drive Type/No. Speeds	ECM/1	ECM/1	PSC/1
CFM [L/s]	12,000 [5663]	12,000 [5663]	12,000 [5663]
No. Motors/HP	3 at 1/2HP	3 at 3/4HP	3 at 1/2HP
Motor RPM	1,100	1,100	1,100
Refrigerant Charge Oz. [g]	656.5 [18,611]	656.5 [18,611]	656.5 [18,611]
Weights			
Net Weight lbs. [kg]	832 [337]	832 [337]	832 [337]
Ship Weight lbs. [kg]	852 [386]	852 [386]	852 [386]

NOTES:

A. Cooling Performance is rated at 95°F ambient, 80°F entering dry bulb, 67°F entering wet bulb. Gross capacity does not include the effect of fan motor heat. AHRI capacity is net and includes the effect of fan motor heat. Units are suitable for operation to 20% of nominal cfm. Units are certified in accordance with the Unitary Air Conditioner Equipment certification program, which is based on AHRI Standard 340/360.

B. EER and Integrated Efficiency Ratio (IEER) is rated at AHRI conditions in accordance with AHRI Standard 340/360.

C. Outdoor Sound Rating shown is tested in accordance with AHRI Standard 270.

[] Designates Metric Conversions

GENERAL DATA—RACY2 MODELS—20 TONS [70.3 kW]

Model RACY2 Series	240CAZ	240DAZ	240YAZ
Cooling Performance^A			
Gross Cooling Capacity Btu/h [kW]	240,000 [70.3]	240,000 [70.3]	240,000 [70.3]
EER	10.0	10.0	10.0
IEER ^B	13.2	13.2	13.2
Nominal CFM/AHRI Rated CFM [L/s]	6,800/6,650 [3,209/3,138]	6,800/6,650 [3,209/3,138]	6,800/6,650 [3,209/3,138]
AHRI Net Cooling Capacity Btu/h [kW]	240,000 [70.3]	240,000 [70.3]	240,000 [70.3]
Net Sensible Capacity Btu/h [kW]	165,000 [48.4]	165,000 [48.4]	165,000 [48.4]
Net Latent Capacity Btu/h [kW]	75,000 [22.0]	75,000 [22.0]	75,000 [22.0]
Compressor			
No./Type	2/Scroll	2/Scroll	2/Scroll
Outdoor Sound Rating (dB)^C			
	90	90	90
Outdoor Coil - Fin Type			
Tube Type	Louvered	Louvered	Louvered
Tube Diameter	Rifled	Rifled	Rifled
Outer Face Area sq. ft. [sq. m]	0.375	0.375	0.375
Inner Face Area sq. ft. [sq. m]	30.3 [2.8]	30.3 [2.8]	30.3 [2.8]
Rows/FPI [FPcm]	30.3 [2.8]	30.3 [2.8]	30.3 [2.8]
	3 / 18 [46]	3 / 18 [46]	3 / 18 [46]
Outdoor Fan - Type			
No. Blades/Diameter in. [mm]	Propeller	Propeller	Propeller
Drive Type/No. Speeds	4/24 [609]	4/24 [609]	4/24 [609]
CFM [L/s]	ECM/1	ECM/1	PSC/1
No. Motors/HP	12,000 [5663]	12,000 [5663]	12,000 [5663]
Motor RPM	3 at 1/2HP	3 at 3/4HP	3 at 1/2HP
	1,100	1,100	1,100
Refrigerant Charge Oz. [g]			
	587.5 [16,655]	587.5 [16,655]	587.5 [16,655]
Weights			
Net Weight lbs. [kg]	926 [420]	926 [420]	926 [420]
Ship Weight lbs. [kg]	946 [429]	946 [429]	946 [429]

NOTES:

A. Cooling Performance is rated at 95°F ambient, 80°F entering dry bulb, 67°F entering wet bulb. Gross capacity does not include the effect of fan motor heat. AHRI capacity is net and includes the effect of fan motor heat. Units are suitable for operation to 20% of nominal cfm. Units are certified in accordance with the Unitary Air Conditioner Equipment certification program, which is based on AHRI Standard 340/360.

B. EER and Integrated Efficiency Ratio (IEER) is rated at AHRI conditions in accordance with AHRI Standard 340/360.

C. Outdoor Sound Rating shown is tested in accordance with AHRI Standard 270.

[] Designates Metric Conversions

UNIT DIMENSIONS

MODEL NO.	OPERATING						SHIPPING					
	H (Height)		L (Length)		W (Width)		H (Height)		L (Length)		W (Width)	
	INCHES	mm	INCHES	mm	INCHES	mm	INCHES	mm	INCHES	mm	INCHES	mm
RACY2078	51.00	1295	35.75	908	35.75	908	53.00	1346	38.38	975	38.38	975
RACY2090	51.00	1295	35.75	908	35.75	908	53.00	1346	38.38	975	38.38	975
RACY2119	51.00	1295	35.75	908	35.75	908	53.00	1346	38.38	975	38.38	975
RACY2120	44.00	1118	74.25	1886	40.00	1016	45.00	1143	75.50	1918	41.00	1041
RACY2150	44.00	1118	74.25	1886	40.00	1016	45.00	1143	75.50	1918	41.00	1041
RACY2180	44.00	1118	89.89	2283	40.00	1016	45.00	1143	91.00	2311	41.00	1041
RACY2240	44.00	1118	89.89	2283	40.00	1016	45.00	1143	91.00	2311	41.00	1041

ELECTRICAL AND PHYSICAL DATA

ELECTRICAL DATA – RACY2 SERIES									
		078CAZ	078DAZ	078YAZ	090CAZ	090DAZ	090YAZ	119CAZ	119DAZ
Unit Information	Unit Operating Voltage Range	187-253	414-506	541-610	187-253	414-506	541-610	187-253	414-506
	Volts	208/230	460	575	208/230	460	575	208/230	460
	Minimum Circuit Ampacity	39/39	17/17	13	39/39	17/17	13	39/39	21
	Minimum Overcurrent Protection Device Size	45	20	15	45	20	15	60	30
	Maximum Overcurrent Protection Device Size	60	25	20	60	25	20	70	35
Compressor Motor	No.	1	1	1	1	1	1	1	1
	Volts	208/230	460	575	208/230	460	575	208/230	460
	Phase	3	3	3	3	3	3	3	3
	Amps (RLA), Comp. 1	26.3	11	9.2	26.3	11	9.2	26.5	14
	Amps (LRA), Comp. 1	178.5	95.3	65	178.5	95.3	65	255	123
Condenser Motor	No.	1	1	1	1	1	1	1	1
	Volts	208/230	460	575	208/230	460	575	208/230	460
	Phase	1	1	1	1	1	1	1	1
	HP	1/2	3/4	1/2	1/2	3/4	1/2	1/2	3/4
	Amps (FLA, each)	5.2	3	1	5.2	3	1	5.2	3
	Amps (LRA, each)	—	—	2.2	—	—	2.2	—	—

ELECTRICAL DATA – RACY2 SERIES							
		120CAZ	120DAZ	120YAZ	150CAZ	150DAZ	150YAZ
Unit Information	Unit Operating Voltage Range	187-253	414-506	541-610	187-253	414-506	541-610
	Volts	208/230	460	575	208/230	460	575
	Minimum Circuit Ampacity	44/44	24	17	61/61	26	19
	Minimum Overcurrent Protection Device Size	60	30	20	70	30	20
	Maximum Overcurrent Protection Device Size	70	35	25	80	30	25
Compressor Motor	No.	1	1	1	1	1	1
	Volts	208/230	460	575	208/230	460	575
	Phase	3	3	3	3	3	3
	Amps (RLA), Comp. 1	26.5	14	11.5	44.8	18.4	14.4
	Amps (LRA), Comp. 1	255	123	93.7	332.4	149.2	108
Condenser Motor	No.	2	2	2	2	2	2
	Volts	208/230	460	575	208/230	460	575
	Phase	1	1	1	1	1	1
	HP	1/2	3/4	1/2	1/2	3/4	1/2
	Amps (FLA, each)	5.2	3	1	5.2	3	1
	Amps (LRA, each)	—	—	2.2	—	—	2.2

ELECTRICAL AND PHYSICAL DATA (CONTINUED)

ELECTRICAL DATA – RACY2 SERIES							
		180CAZ	180DAZ	180YAZ	240CAZ	240DAZ	240YAZ
Unit Information	Unit Operating Voltage Range	187-253	414-506	541-610	187-253	414-506	541-610
	Volts	208/230	460	575	208/230	460	575
	Minimum Circuit Ampacity	78/78	35	24	91/91	44	33
	Minimum Overcurrent Protection Device Size	90	40	30	100	50	40
	Maximum Overcurrent Protection Device Size	100	45	30	110	50	40
Compressor Motor	No.	1	1	1	1	1	1
	Volts	208/230	460	575	208/230	460	575
	Phase	3	3	3	3	3	3
	Amps (RLA), Comp. 1	55.4	23	18	66.6	30.8	25.8
	Amps (LRA), Comp. 1	357	206	156	510	280	215.2
Condenser Motor	No.	3	3	3	3	3	3
	Volts	208/230	460	575	208/230	460	575
	Phase	1	1	1	1	1	1
	HP	1/2	3/4	1/2	1/2	3/4	1/2
	Amps (FLA, each)	5.2	3	1	5.2	3	1
	Amps (LRA, each)	—	—	2.2	—	—	2.2

A2L REFRIGERANT INSTALLATION SAFETY DATA

QMIN AT RATING PLATE CHARGE WEIGHT [0'-200' 1/2" LINE SET]						
RACY2		078/090 [0']	078/090 [50']	078/090 [100']	078/090 [150']	078/090 [200']
Refrigerant Chart Weight (oz)		338.0	388.0	438.0	488.0	538.0
Minimum Total Room Area, T _{Amin} (ft ²)		623.0	715.0	807.0	900.0	992.0
Minimum Circulation Airflow, Q _{min} (CFM)		1124.0	1291.0	1457.0	1623.0	1789.0
INSTALLED ALTITUDE (FT ABOVE SEA LEVEL)	ALTITUDE ADJUSTMENT FACTOR	MINIMUM TOTAL CONDITIONED ROOM AREA, T _{Amin} (SQ FT)				
0	1.000	623	715	807	900	992
1000	1.025	638	733	827	922	1017
2000	1.051	655	751	848	946	1042
3000	1.078	672	771	870	970	1070
4000	1.107	690	792	893	996	1098
5000	1.138	709	813	918	1024	1129
6000	1.170	729	836	944	1053	1161
6500	1.187	739	848	958	1068	1177

QMIN AT RATING PLATE CHARGE WEIGHT [0'-200' 1/2" LINE SET]						
RACY2		119 [0']	119 [50']	119 [100']	119 [150']	119 [200']
Refrigerant Chart Weight (oz)		328.0	378.0	428.0	478.0	528.0
Minimum Total Room Area, T _{Amin} (ft ²)		605.0	697.0	789.0	881.0	973.0
Minimum Circulation Airflow, Q _{min} (CFM)		1091.0	1257.0	1424.0	1590.0	1756.0
INSTALLED ALTITUDE (FT ABOVE SEA LEVEL)	ALTITUDE ADJUSTMENT FACTOR	MINIMUM TOTAL CONDITIONED ROOM AREA, T _{Amin} (SQ FT)				
0	1.000	605	697	789	881	973
1000	1.025	620	714	808	903	997
2000	1.051	635	732	829	926	1023
3000	1.078	652	751	851	950	1049
4000	1.107	669	771	873	976	1078
5000	1.138	688	793	898	1002	1107
6000	1.170	707	815	923	1031	1139
6500	1.187	717	827	936	1046	1155

[] Designates Metric Conversions

A2L REFRIGERANT INSTALLATION SAFETY DATA (CONTINUED)

QMIN AT RATING PLATE CHARGE WEIGHT [0' - 200' 5/8" LINE SET]						
RACY2		120 [0']	120 [50']	120 [100']	120 [150']	120 [200']
Refrigerant Chart Weight (oz)		373.5	448.5	523.5	598.5	673.5
Minimum Total Room Area, T _{Amin} (ft ²)		688.0	781.0	873.0	965.0	1057.0
Minimum Circulation Airflow, Q _{min} (CFM)		1242.0	1409.0	1575.0	1741.0	1908.0
INSTALLED ALTITUDE (FT ABOVE SEA LEVEL)	ALTITUDE ADJUSTMENT FACTOR	MINIMUM TOTAL CONDITIONED ROOM AREA, T _{AMIN} (SQ FT)				
0	1.000	688	781	873	965	1057
1000	1.025	706	800	894	989	1083
2000	1.051	723	820	917	1014	1111
3000	1.078	742	842	941	1040	1140
4000	1.107	762	864	966	1068	1170
5000	1.138	783	888	993	1098	1203
6000	1.170	805	913	1021	1129	1237
6500	1.187	817	926	1036	1145	1254

QMIN AT RATING PLATE CHARGE WEIGHT [0' - 200' 5/8" LINE SET]						
RACY2		150 [0']	150 [50']	150 [100']	150 [150']	150 [200']
Refrigerant Chart Weight (oz)		381.5	456.5	531.5	606.5	681.5
Minimum Total Room Area, T _{Amin} (ft ²)		703.2	795.4	887.5	979.7	1071.9
Minimum Circulation Airflow, Q _{min} (CFM)		1269.0	1435.0	1602.0	1768.0	1934.0
INSTALLED ALTITUDE (FT ABOVE SEA LEVEL)	ALTITUDE ADJUSTMENT FACTOR	MINIMUM TOTAL CONDITIONED ROOM AREA, T _{AMIN} (SQ FT)				
0	1.000	703	795	888	980	1072
1000	1.025	721	733	827	922	1017
2000	1.051	739	751	848	946	1042
3000	1.078	758	771	870	970	1070
4000	1.107	779	792	893	996	1098
5000	1.138	800	813	918	1024	1129
6000	1.170	823	836	944	1053	1161
6500	1.187	834	848	958	1068	1177

[] Designates Metric Conversions

A2L REFRIGERANT INSTALLATION SAFETY DATA (CONTINUED)

QMIN AT RATING PLATE CHARGE WEIGHT [0' - 200' 5/8" LINE SET]						
RACY2		180 [0']	180 [50']	180 [100']	180 [150']	180 [200']
Refrigerant Chart Weight (oz)		681.5	756.5	831.5	906.5	981.5
Minimum Total Room Area, TAmin (ft²)		1256.2	1348.3	1440.5	1532.7	1624.8
Minimum Circulation Airflow, Qmin (CFM)		2267.0	2433.0	2599.0	2766.0	2932.0
INSTALLED ALTITUDE (FT ABOVE SEA LEVEL)	ALTITUDE ADJUSTMENT FACTOR	MINIMUM TOTAL CONDITIONED ROOM AREA, TAMIN (SQ FT)				
0	1.000	1256	1348	1441	1533	1625
1000	1.025	1287	1382	1476	1571	1665
2000	1.051	1320	1417	1514	1611	1707
3000	1.078	1355	1454	1553	1653	1752
4000	1.107	1391	1493	1595	1697	1799
5000	1.138	1429	1534	1639	1744	1849
6000	1.170	1470	1577	1685	1793	1901
6500	1.187	1491	1600	1709	1819	1928

QMIN AT RATING PLATE CHARGE WEIGHT [0' - 200' 7/8" LINE SET]						
RACY2		240 [0']	240 [50']	240 [100']	240 [150']	240 [200']
Refrigerant Chart Weight (oz)		537.5	692.5	847.5	1002.5	1157.5
Minimum Total Room Area, TAmin (ft²)		990.8	1082.9	1175.1	1267.2	1359.4
Minimum Circulation Airflow, Qmin (CFM)		1788.0	1954.0	2120.0	2287.0	2453.0
INSTALLED ALTITUDE (FT ABOVE SEA LEVEL)	ALTITUDE ADJUSTMENT FACTOR	MINIMUM TOTAL CONDITIONED ROOM AREA, TAMIN (SQ FT)				
0	1.000	991	1083	1175	1267	1359
1000	1.025	1015	1110	1204	1299	1393
2000	1.051	1041	1138	1235	1332	1429
3000	1.078	1068	1168	1267	1366	1466
4000	1.107	1097	1199	1301	1403	1505
5000	1.138	1127	1232	1337	1442	1547
6000	1.170	1159	1267	1375	1483	1590
6500	1.187	1176	1285	1394	1504	1613

[] Designates Metric Conversions

COOLING PERFORMANCE DATA—RACY2078 & RACY2090

		ENTERING INDOOR AIR @ 80°F [26.7°C] dbE ①									
wbE		71°F [21.7°C]			67°F [19.4°C]			63°F [17.2°C]			
CFM [L/s]		3475 [1640]	2400 [1133]	2525 [1192]	3475 [1640]	2400 [1133]	2525 [1192]	3475 [1640]	2400 [1133]	2525 [1192]	
DR ①		0.05	0.09	0.12	0.05	0.09	0.12	0.05	0.09	0.12	
OUTDOOR DRY BULB TEMPERATURE °F [°C]	75°F [23.9]°C	Total kBtu/h [kW] Sens kBtu/h [kW] Power	110.1 [32.3] 66.3 [19.4] 6.2	101.8 [29.8] 54.9 [16.1] 5.9	102.8 [30.1] 56.2 [16.5] 6.0	99.3 [29.1] 77.4 [22.7] 5.9	91.8 [26.9] 64.0 [18.8] 5.7	92.7 [27.2] 65.6 [19.2] 5.7	93.3 [27.3] 86.3 [25.3] 6.0	86.2 [25.3] 71.4 [20.9] 5.8	87.0 [25.5] 73.1 [21.4] 5.8
	80°F [26.7]°C	Total kBtu/h [kW] Sens kBtu/h [kW] Power	110.6 [32.4] 67.5 [19.8] 6.7	102.3 [30.0] 55.8 [16.4] 6.4	103.2 [30.2] 57.2 [16.8] 6.4	99.8 [29.2] 78.6 [23.0] 6.5	92.2 [27.0] 65.0 [19.1] 6.2	93.1 [27.3] 66.6 [19.5] 6.2	93.7 [27.5] 87.5 [25.6] 6.5	86.7 [25.4] 72.4 [21.2] 6.3	87.5 [25.6] 74.1 [21.7] 6.3
	85°F [29.4]°C	Total kBtu/h [kW] Sens kBtu/h [kW] Power	111.0 [32.5] 68.4 [20.0] 7.2	102.6 [30.1] 56.6 [16.6] 6.9	103.6 [30.4] 57.9 [17.0] 6.9	100.1 [29.3] 79.5 [23.3] 7.0	92.6 [27.1] 65.7 [19.3] 6.7	93.5 [27.4] 67.3 [19.7] 6.7	94.1 [27.6] 88.4 [25.9] 7.0	87.0 [25.5] 73.1 [21.4] 6.8	87.8 [25.7] 74.9 [22.0] 6.8
	90°F [32.2]°C	Total kBtu/h [kW] Sens kBtu/h [kW] Power	111.2 [32.6] 69.0 [20.2] 7.7	102.8 [30.1] 57.1 [16.7] 7.4	103.8 [30.4] 58.5 [17.1] 7.4	100.4 [29.4] 80.1 [23.5] 7.5	92.8 [27.2] 66.3 [19.4] 7.2	93.7 [27.5] 67.9 [19.9] 7.2	94.3 [27.6] 89.1 [26.1] 7.5	87.2 [25.6] 73.7 [21.6] 7.3	88.1 [25.8] 75.4 [22.1] 7.3
	95°F [35]°C	Total kBtu/h [kW] Sens kBtu/h [kW] Power	111.3 [32.6] 69.4 [20.3] 8.2	103.0 [30.2] 57.4 [16.8] 7.9	103.9 [30.5] 58.8 [17.2] 7.9	100.5 [29.5] 80.5 [23.6] 8.0	92.9 [27.2] 66.6 [19.5] 7.7	93.8 [27.5] 68.2 [20.0] 7.7	94.5 [27.7] 89.4 [26.2] 8.1	87.4 [25.6] 74.0 [21.7] 7.7	88.2 [25.8] 75.8 [22.2] 7.8
	100°F [37.8]°C	Total kBtu/h [kW] Sens kBtu/h [kW] Power	111.3 [32.6] 69.6 [20.4] 8.7	103.0 [30.2] 57.5 [16.9] 8.4	103.9 [30.5] 58.9 [17.3] 8.4	100.5 [29.5] 80.7 [23.7] 8.5	92.9 [27.2] 66.7 [19.5] 8.1	93.8 [27.5] 68.3 [20.0] 8.2	94.5 [27.7] 89.6 [26.3] 8.6	87.4 [25.6] 74.1 [21.7] 8.2	88.2 [25.8] 75.9 [22.2] 8.3
	105°F [40.6]°C	Total kBtu/h [kW] Sens kBtu/h [kW] Power	111.2 [32.6] 69.5 [20.4] 9.2	102.9 [30.2] 57.5 [16.9] 8.8	103.8 [30.4] 58.9 [17.3] 8.9	100.4 [29.4] 80.6 [23.6] 9.0	92.8 [27.2] 66.6 [19.5] 8.6	93.7 [27.5] 68.3 [20.0] 8.7	94.4 [27.7] 89.5 [26.2] 9.1	87.3 [25.6] 74.0 [21.7] 8.7	88.1 [25.8] 75.8 [22.2] 8.8
	110°F [43.3]°C	Total kBtu/h [kW] Sens kBtu/h [kW] Power	111.0 [32.5] 69.1 [20.3] 9.7	102.6 [30.1] 57.2 [16.8] 9.3	103.6 [30.4] 58.5 [17.1] 9.4	100.1 [29.3] 80.2 [23.5] 9.5	92.6 [27.1] 66.3 [19.4] 9.1	93.5 [27.4] 67.9 [19.9] 9.2	94.1 [27.6] 89.1 [26.1] 9.6	87.0 [25.5] 73.7 [21.6] 9.2	87.9 [25.8] 75.5 [22.1] 9.2
	115°F [46.1]°C	Total kBtu/h [kW] Sens kBtu/h [kW] Power	110.6 [32.4] 68.5 [20.1] 10.2	102.3 [30.0] 56.6 [16.6] 9.8	103.3 [30.3] 58.0 [17.0] 9.9	99.8 [29.2] 79.6 [23.3] 10.0	92.3 [27.1] 65.8 [19.3] 9.6	93.1 [27.3] 67.4 [19.8] 9.7	93.8 [27.5] 88.5 [25.9] 10.1	86.7 [25.4] 73.2 [21.5] 9.7	87.5 [25.6] 75.0 [22.0] 9.7
	120°F [48.9]°C	Total kBtu/h [kW] Sens kBtu/h [kW] Power	110.2 [32.3] 67.6 [19.8] 10.7	101.9 [29.9] 55.9 [16.4] 10.3	102.8 [30.1] 57.3 [16.8] 10.4	99.3 [29.1] 78.7 [23.1] 10.5	91.8 [26.9] 65.1 [19.1] 10.1	92.7 [27.2] 66.7 [19.5] 10.1	93.3 [27.3] 87.6 [25.7] 10.6	86.3 [25.3] 72.5 [21.2] 10.2	87.1 [25.5] 74.2 [21.7] 10.2
	125°F [51.7]°C	Total kBtu/h [kW] Sens kBtu/h [kW] Power	109.6 [32.1] 66.5 [19.5] 11.2	101.3 [29.7] 55.0 [16.1] 10.8	102.3 [30.0] 56.3 [16.5] 10.8	98.7 [28.9] 77.6 [22.7] 11.0	91.3 [26.8] 64.2 [18.8] 10.6	92.1 [27.0] 65.7 [19.3] 10.6	92.7 [27.2] 86.5 [25.4] 11.1	85.7 [25.1] 71.5 [21.0] 10.7	86.5 [25.4] 73.3 [21.5] 10.7

DR —Depression ratio
dbE —Entering air dry bulb
wbE—Entering air wet bulb

Total —Total capacity x 1000 Btu/h
Sens —Sensible capacity x 1000 Btu/h
Power—kW input

NOTES:

① When the entering air dry bulb is other than 80°F [27°C], adjust the sensible capacity from the table by adding [1.10 x CFM x (1 – DR) x (dbE – 80)].

[] Designates Metric Conversions

COOLING PERFORMANCE DATA—RACY2119

		ENTERING INDOOR AIR @ 80°F [26.7°C] dbE ①									
		71°F [21.7°C]			67°F [19.4°C]			63°F [17.2°C]			
		4250 [2006]	3900 [1841]	3075 [1451]	4250 [2006]	3900 [1841]	3075 [1451]	4250 [2006]	3900 [1841]	3075 [1451]	
		DR ①	0.05	0.09	0.12	0.05	0.09	0.12	0.05	0.09	0.12
O U T D O O R D R Y B U L B T E M P E R A T U R E ° F [° C]	75°F [23.9]°C	Total kBtu/h [kW]	123.9 [36.3]	121.9 [35.7]	117.2 [34.3]	115.7 [33.9]	113.8 [33.4]	109.4 [32.1]	111.1 [32.6]	109.3 [32.0]	105.1 [30.8]
		Sens kBtu/h [kW]	76.4 [22.4]	73.3 [21.5]	66.1 [19.4]	87.4 [25.6]	83.9 [24.6]	75.6 [22.2]	102.1 [29.9]	98.0 [28.7]	88.4 [25.9]
		Power	7.4	7.4	7.2	7.3	7.2	7.1	7.2	7.1	7.0
	80°F [26.7]°C	Total kBtu/h [kW]	124.8 [36.6]	122.8 [36.0]	118.0 [34.6]	116.5 [34.1]	114.7 [33.6]	110.3 [32.3]	112.0 [32.8]	110.2 [32.3]	105.9 [31.0]
		Sens kBtu/h [kW]	77.5 [22.7]	74.4 [21.8]	67.1 [19.7]	88.5 [25.9]	85.0 [24.9]	76.6 [22.5]	103.3 [30.3]	99.1 [29.0]	89.4 [26.2]
		Power	8.0	8.0	7.8	7.9	7.9	7.7	7.8	7.7	7.6
	85°F [29.4]°C	Total kBtu/h [kW]	125.0 [36.6]	123.0 [36.0]	118.3 [34.7]	116.8 [34.2]	114.9 [33.7]	110.5 [32.4]	112.2 [32.9]	110.4 [32.4]	106.2 [31.1]
		Sens kBtu/h [kW]	78.0 [22.9]	74.9 [22.0]	67.5 [19.8]	89.1 [26.1]	85.5 [25.1]	77.0 [22.6]	103.8 [30.4]	99.6 [29.2]	89.8 [26.3]
		Power	8.7	8.6	8.5	8.6	8.5	8.3	8.4	8.4	8.2
	90°F [32.2]°C	Total kBtu/h [kW]	124.6 [36.5]	122.6 [35.9]	117.9 [34.6]	116.4 [34.1]	114.5 [33.6]	110.1 [32.3]	111.8 [32.8]	110.0 [32.2]	105.8 [31.0]
		Sens kBtu/h [kW]	77.9 [22.8]	74.8 [21.9]	67.4 [19.8]	88.9 [26.1]	85.3 [25.0]	76.9 [22.5]	103.7 [30.4]	99.5 [29.2]	89.7 [26.3]
		Power	9.4	9.3	9.1	9.2	9.2	9.0	9.1	9.0	8.9
95°F [35]°C	Total kBtu/h [kW]	123.6 [36.2]	121.6 [35.6]	116.9 [34.3]	115.4 [33.8]	113.5 [33.3]	109.1 [32.0]	110.8 [32.5]	109.0 [31.9]	104.8 [30.7]	
	Sens kBtu/h [kW]	77.1 [22.6]	74.0 [21.7]	66.7 [19.5]	88.1 [25.8]	84.6 [24.8]	76.2 [22.3]	102.9 [30.2]	98.8 [29.0]	89.0 [26.1]	
	Power	10.0	10.0	9.8	9.9	9.8	9.6	9.8	9.7	9.5	
100°F [37.8]°C	Total kBtu/h [kW]	121.9 [35.7]	120.0 [35.2]	115.4 [33.8]	113.7 [33.3]	111.9 [32.8]	107.6 [31.5]	109.1 [32.0]	107.4 [31.5]	103.2 [30.2]	
	Sens kBtu/h [kW]	75.7 [22.2]	72.7 [21.3]	65.5 [19.2]	86.7 [25.4]	83.2 [24.4]	75.0 [22.0]	101.5 [29.7]	97.4 [28.5]	87.8 [25.7]	
	Power	10.7	10.6	10.4	10.6	10.5	10.3	10.5	10.4	10.2	
105°F [40.6]°C	Total kBtu/h [kW]	119.6 [35.1]	117.7 [34.5]	113.2 [33.2]	111.4 [32.6]	109.6 [32.1]	105.4 [30.9]	106.8 [31.3]	105.1 [30.8]	101.1 [29.6]	
	Sens kBtu/h [kW]	73.6 [21.6]	70.7 [20.7]	63.7 [18.7]	84.6 [24.8]	81.2 [23.8]	73.2 [21.5]	99.4 [29.1]	95.4 [28.0]	86.0 [25.2]	
	Power	11.4	11.3	11.1	11.3	11.2	11.0	11.2	11.1	10.9	
110°F [43.3]°C	Total kBtu/h [kW]	116.7 [34.2]	114.8 [33.6]	110.4 [32.4]	108.5 [31.8]	106.8 [31.3]	102.7 [30.1]	103.9 [30.5]	102.3 [30.0]	98.3 [28.8]	
	Sens kBtu/h [kW]	70.9 [20.8]	68.1 [20.0]	61.3 [18.0]	81.9 [24.0]	78.6 [23.0]	70.9 [20.8]	96.7 [28.3]	92.8 [27.2]	83.6 [24.5]	
	Power	12.1	12.0	11.8	12.0	11.9	11.7	11.9	11.8	11.6	
115°F [46.1]°C	Total kBtu/h [kW]	113.2 [33.2]	111.4 [32.6]	107.1 [31.4]	105.0 [30.8]	103.3 [30.3]	99.3 [29.1]	100.4 [29.4]	98.8 [29.0]	95.0 [27.8]	
	Sens kBtu/h [kW]	67.6 [19.8]	64.8 [19.0]	58.4 [17.1]	78.6 [23.0]	75.4 [22.1]	68.0 [19.9]	93.3 [27.3]	89.6 [26.3]	80.7 [23.7]	
	Power	12.8	12.7	12.5	12.7	12.6	12.4	12.6	12.5	12.3	
120°F [48.9]°C	Total kBtu/h [kW]	109.0 [31.9]	107.2 [31.4]	103.1 [30.2]	100.8 [29.5]	99.2 [29.1]	95.3 [27.9]	96.2 [28.2]	94.7 [27.8]	91.0 [26.7]	
	Sens kBtu/h [kW]	63.5 [18.6]	61.0 [17.9]	55.0 [16.1]	74.6 [21.9]	71.6 [21.0]	64.5 [18.9]	89.3 [26.2]	85.7 [25.1]	77.3 [22.7]	
	Power	13.6	13.5	13.2	13.5	13.3	13.1	13.3	13.2	13.0	
125°F [51.7]°C	Total kBtu/h [kW]	104.2 [30.5]	102.5 [30.0]	98.6 [28.9]	96.0 [28.1]	94.4 [27.7]	90.8 [26.6]	91.4 [26.8]	89.9 [26.3]	86.5 [25.4]	
	Sens kBtu/h [kW]	58.9 [17.3]	56.5 [16.6]	50.9 [14.9]	69.9 [20.5]	67.1 [19.7]	60.5 [17.7]	84.7 [24.8]	81.3 [23.8]	73.2 [21.5]	
	Power	14.3	14.2	13.9	14.2	14.1	13.8	14.1	14.0	13.7	

DR —Depression ratio
dbE —Entering air dry bulb
wbE —Entering air wet bulb

Total —Total capacity x 1000 Btu/h
Sens —Sensible capacity x 1000 Btu/h
Power —kW input

NOTES:

① When the entering air dry bulb is other than 80°F [27°C], adjust the sensible capacity from the table by adding [1.10 x CFM x (1 - DR) x (dbE - 80)].

[] Designates Metric Conversions

COOLING PERFORMANCE DATA—RACY2120

ENTERING INDOOR AIR @ 80°F [26.7°C] dbE ①											
wbE		71°F [21.7°C]			67°F [19.4°C]			63°F [17.2°C]			
CFM [L/s]		4400 [2077]	3900 [1841]	3175 [1498]	4400 [2077]	3900 [1841]	3175 [1498]	4400 [2077]	3900 [1841]	3175 [1498]	
DR ①		0.05	0.09	0.12	0.05	0.09	0.12	0.05	0.09	0.12	
OUTDOOR DRY BULB TEMPERATURE °F [°C]	75°F [23.9]°C	Total kBtu/h [kW] Sens kBtu/h [kW] Power	130.0 [38.1] 77.7 [22.8] 7.6	127.0 [37.2] 73.3 [21.5] 7.5	122.7 [36.0] 67.0 [19.6] 7.4	119.3 [35.0] 84.7 [24.8] 7.7	116.6 [34.2] 79.9 [23.4] 7.6	112.7 [33.0] 73.0 [21.4] 7.5	112.1 [32.9] 95.2 [27.9] 7.8	109.6 [32.1] 89.9 [26.3] 7.7	105.9 [31.0] 82.1 [24.1] 7.6
	80°F [26.7]°C	Total kBtu/h [kW] Sens kBtu/h [kW] Power	131.4 [38.5] 80.3 [23.5] 8.3	128.4 [37.6] 75.8 [22.2] 8.2	124.1 [36.4] 69.2 [20.3] 8.1	120.7 [35.4] 87.3 [25.6] 8.4	118.0 [34.6] 82.4 [24.2] 8.3	114.0 [33.4] 75.2 [22.0] 8.1	113.5 [33.3] 97.9 [28.7] 8.5	110.9 [32.5] 92.3 [27.1] 8.4	107.2 [31.4] 84.3 [24.7] 8.2
	85°F [29.4]°C	Total kBtu/h [kW] Sens kBtu/h [kW] Power	132.0 [38.7] 82.2 [24.1] 8.9	129.0 [37.8] 77.6 [22.7] 8.8	124.6 [36.5] 70.8 [20.8] 8.7	121.3 [35.6] 89.2 [26.1] 9.0	118.6 [34.8] 84.1 [24.6] 8.9	114.6 [33.6] 76.8 [22.5] 8.8	114.1 [33.4] 99.7 [29.2] 9.1	111.5 [32.7] 94.1 [27.6] 9.0	107.8 [31.6] 85.9 [25.2] 8.9
	90°F [32.2]°C	Total kBtu/h [kW] Sens kBtu/h [kW] Power	131.9 [38.7] 83.3 [24.4] 9.6	128.9 [37.8] 78.6 [23.0] 9.5	124.5 [36.5] 71.8 [21.0] 9.3	121.2 [35.5] 90.2 [26.4] 9.7	118.5 [34.7] 85.1 [24.9] 9.6	114.4 [33.5] 77.8 [22.8] 9.4	114.0 [33.4] 100.8 [29.5] 9.7	111.4 [32.6] 95.1 [27.9] 9.6	107.7 [31.6] 86.9 [25.5] 9.5
	95°F [35]°C	Total kBtu/h [kW] Sens kBtu/h [kW] Power	131.0 [38.4] 83.6 [24.5] 10.2	128.0 [37.5] 78.8 [23.1] 10.1	123.7 [36.3] 72.0 [21.1] 9.9	120.3 [35.3] 90.5 [26.5] 10.3	117.6 [34.5] 85.4 [25.0] 10.2	113.6 [33.3] 78.0 [22.9] 10.0	113.1 [33.1] 101.1 [29.6] 10.4	110.5 [32.4] 95.4 [28.0] 10.2	106.8 [31.3] 87.1 [25.5] 10.1
	100°F [37.8]°C	Total kBtu/h [kW] Sens kBtu/h [kW] Power	129.3 [37.9] 83.1 [24.4] 10.8	126.4 [37.0] 78.4 [23.0] 10.7	122.1 [35.8] 71.6 [21.0] 10.5	118.7 [34.8] 90.0 [26.4] 10.9	116.0 [34.0] 84.9 [24.9] 10.8	112.1 [32.9] 77.6 [22.7] 10.6	111.5 [32.7] 100.6 [29.5] 11.0	108.9 [31.9] 94.9 [27.8] 10.8	105.3 [30.9] 86.7 [25.4] 10.7
	105°F [40.6]°C	Total kBtu/h [kW] Sens kBtu/h [kW] Power	126.9 [37.2] 81.8 [24.0] 11.4	124.1 [36.4] 77.2 [22.6] 11.2	119.9 [35.1] 70.5 [20.7] 11.1	116.3 [34.1] 88.7 [26.0] 11.5	113.6 [33.3] 83.7 [24.5] 11.3	109.8 [32.2] 76.5 [22.4] 11.1	109.1 [32.0] 99.3 [29.1] 11.5	106.6 [31.2] 93.7 [27.5] 11.4	103.0 [30.2] 85.6 [25.1] 11.2
	110°F [43.3]°C	Total kBtu/h [kW] Sens kBtu/h [kW] Power	123.8 [36.3] 79.7 [23.4] 11.9	121.0 [35.5] 75.2 [22.0] 11.8	116.9 [34.3] 68.7 [20.1] 11.6	113.1 [33.1] 86.7 [25.4] 12.0	110.5 [32.4] 81.8 [24.0] 11.9	106.8 [31.3] 74.7 [21.9] 11.7	105.9 [31.0] 97.2 [28.5] 12.1	103.5 [30.3] 91.7 [26.9] 12.0	100.0 [29.3] 83.8 [24.6] 11.8
	115°F [46.1]°C	Total kBtu/h [kW] Sens kBtu/h [kW] Power	119.9 [35.1] 76.9 [22.5] 12.5	117.1 [34.3] 72.5 [21.2] 12.3	113.2 [33.2] 66.2 [19.4] 12.1	109.2 [32.0] 83.8 [24.6] 12.5	106.7 [31.3] 79.1 [23.2] 12.4	103.1 [30.2] 72.2 [21.2] 12.2	102.0 [29.9] 94.4 [27.7] 12.6	99.7 [29.2] 89.1 [26.1] 12.5	96.3 [28.2] 81.3 [23.8] 12.3
	120°F [48.9]°C	Total kBtu/h [kW] Sens kBtu/h [kW] Power	115.2 [33.8] 73.2 [21.5] 13.0	112.6 [33.0] 69.1 [20.3] 12.8	108.8 [31.9] 63.1 [18.5] 12.6	104.5 [30.6] 80.2 [23.5] 13.1	102.1 [29.9] 75.7 [22.2] 12.9	98.7 [28.9] 69.1 [20.3] 12.7	97.3 [28.5] 90.7 [26.6] 13.1	95.1 [27.9] 85.6 [25.1] 13.0	91.9 [26.9] 78.2 [22.9] 12.8
	125°F [51.7]°C	Total kBtu/h [kW] Sens kBtu/h [kW] Power	109.8 [32.2] 68.8 [20.2] 13.5	107.3 [31.4] 64.9 [19.0] 13.3	103.6 [30.4] 59.3 [17.4] 13.1	99.1 [29.0] 75.8 [22.2] 13.6	96.8 [28.4] 71.5 [21.0] 13.4	93.6 [27.4] 65.3 [19.1] 13.2	91.9 [26.9] 86.3 [25.3] 13.6	89.8 [26.3] 81.5 [23.9] 13.5	86.8 [25.4] 74.4 [21.8] 13.3

DR —Depression ratio
dbE —Entering air dry bulb
wbE—Entering air wet bulb

Total —Total capacity x 1000 Btu/h
Sens —Sensible capacity x 1000 Btu/h
Power —kW input

NOTES:

① When the entering air dry bulb is other than 80°F [27°C], adjust the sensible capacity from the table by adding [1.10 x CFM x (1 – DR) x (dbE – 80)].

[] Designates Metric Conversions

COOLING PERFORMANCE DATA—RACY2150

		ENTERING INDOOR AIR @ 80°F [26.7°C] dbE ①									
		71°F [21.7°C]			67°F [19.4°C]			63°F [17.2°C]			
wbE		5375 [2537]	4350 [2053]	3875 [1829]	5375 [2537]	4350 [2053]	3875 [1829]	5375 [2537]	4350 [2053]	3875 [1829]	
CFM [L/s]		5375 [2537]	4350 [2053]	3875 [1829]	5375 [2537]	4350 [2053]	3875 [1829]	5375 [2537]	4350 [2053]	3875 [1829]	
DR ①		0.05	0.09	0.12	0.05	0.09	0.12	0.05	0.09	0.12	
O U T D O O R D R Y B U L B T E M P E R A T U R E ° F [° C]	75°F [23.9]°C	Total kBtu/h [kW] Sens kBtu/h [kW] Power	141.4 [41.4] 85.7 [25.1] 8.7	135.6 [39.7] 77.2 [22.6] 8.5	132.9 [39.0] 73.3 [21.5] 8.4	136.1 [39.9] 101.5 [29.7] 8.5	130.5 [38.2] 91.5 [26.8] 8.3	127.9 [37.5] 86.8 [25.4] 8.2	130.7 [38.3] 117.3 [34.4] 8.5	125.4 [36.8] 105.7 [30.1] 8.3	122.9 [36.0] 100.3 [29.4] 8.2
	80°F [26.7]°C	Total kBtu/h [kW] Sens kBtu/h [kW] Power	144.7 [42.4] 88.0 [25.8] 9.7	138.8 [40.7] 79.3 [23.2] 9.5	136.0 [39.9] 75.3 [22.1] 9.4	139.4 [40.9] 103.8 [30.4] 9.4	133.7 [39.2] 93.6 [27.4] 9.3	130.1 [38.4] 88.8 [26.0] 9.2	134.1 [39.3] 119.6 [35.1] 9.5	128.6 [37.7] 107.8 [31.6] 9.3	126.0 [36.9] 102.3 [30.0] 9.2
	85°F [29.4]°C	Total kBtu/h [kW] Sens kBtu/h [kW] Power	148.1 [43.4] 90.4 [26.5] 10.7	142.0 [41.6] 81.4 [23.9] 10.5	139.2 [40.8] 77.3 [22.7] 10.3	142.8 [41.9] 106.2 [31.1] 10.4	136.9 [40.1] 95.6 [28.0] 10.2	134.2 [39.3] 90.8 [26.6] 10.1	137.4 [40.3] 121.9 [35.7] 10.5	131.8 [38.6] 109.9 [32.2] 10.3	129.2 [37.9] 104.3 [30.6] 10.2
	90°F [32.2]°C	Total kBtu/h [kW] Sens kBtu/h [kW] Power	151.4 [44.4] 92.7 [27.2] 11.7	145.2 [42.6] 83.5 [24.5] 11.4	142.3 [41.7] 79.2 [23.2] 11.3	146.1 [42.8] 108.5 [31.8] 11.4	140.1 [41.1] 97.7 [28.6] 11.2	137.3 [40.2] 92.7 [27.2] 11.1	140.8 [41.3] 124.3 [36.4] 11.5	135.0 [39.6] 111.9 [32.8] 11.2	132.3 [38.8] 106.2 [31.1] 11.1
	95°F [35]°C	Total kBtu/h [kW] Sens kBtu/h [kW] Power	154.8 [45.4] 95.0 [27.8] 12.7	148.4 [43.5] 85.6 [25.1] 12.4	145.5 [42.6] 81.2 [23.8] 12.3	149.5 [43.8] 110.8 [32.5] 12.4	143.3 [42.0] 99.8 [29.2] 12.2	140.5 [41.2] 94.7 [27.8] 12.1	144.1 [42.2] 126.6 [37.1] 12.5	138.2 [40.5] 114.0 [33.4] 12.2	135.5 [39.7] 108.2 [31.7] 12.1
	100°F [37.8]°C	Total kBtu/h [kW] Sens kBtu/h [kW] Power	158.1 [46.3] 97.3 [28.5] 13.7	151.7 [44.5] 87.7 [25.7] 13.4	148.6 [43.6] 83.2 [24.4] 13.2	152.8 [44.8] 113.1 [33.1] 13.4	146.5 [42.9] 101.9 [29.9] 13.2	143.6 [42.1] 96.7 [28.3] 13.0	147.5 [43.2] 128.9 [37.8] 13.5	141.4 [41.4] 116.1 [34.0] 13.2	138.6 [40.6] 110.2 [32.3] 13.1
	105°F [40.6]°C	Total kBtu/h [kW] Sens kBtu/h [kW] Power	161.5 [47.3] 99.6 [29.2] 14.7	154.9 [45.4] 89.7 [26.3] 14.4	151.8 [44.5] 85.2 [25.0] 14.2	156.2 [45.8] 115.4 [33.8] 14.4	149.8 [43.9] 104.0 [30.5] 14.1	146.8 [43.0] 98.7 [28.9] 14.0	150.9 [44.2] 131.2 [38.5] 14.5	144.7 [42.4] 118.2 [34.6] 14.2	141.8 [41.6] 112.2 [32.9] 14.0
	110°F [43.3]°C	Total kBtu/h [kW] Sens kBtu/h [kW] Power	164.9 [48.3] 101.9 [29.9] 15.6	158.1 [46.3] 91.8 [26.9] 15.3	154.9 [45.4] 87.1 [25.5] 15.2	159.5 [46.7] 117.7 [34.5] 15.4	153.0 [44.8] 106.1 [31.1] 15.1	149.9 [43.9] 100.6 [29.5] 15.0	154.2 [45.2] 133.5 [39.1] 15.4	147.9 [43.3] 120.3 [35.3] 15.1	144.9 [42.5] 114.1 [33.4] 15.0
	115°F [46.1]°C	Total kBtu/h [kW] Sens kBtu/h [kW] Power	168.2 [49.3] 104.2 [30.5] 16.6	161.3 [47.3] 93.9 [27.5] 16.3	158.1 [46.3] 89.1 [25.5] 16.1	162.9 [47.7] 120.0 [35.2] 16.4	156.2 [45.8] 108.1 [31.7] 16.1	153.1 [44.9] 102.6 [30.1] 15.9	157.6 [46.2] 135.8 [39.8] 16.4	151.1 [44.3] 122.4 [35.9] 16.1	148.1 [43.4] 116.1 [34.0] 16.0
	120°F [48.9]°C	Total kBtu/h [kW] Sens kBtu/h [kW] Power	171.6 [50.3] 106.5 [31.2] 17.6	164.5 [48.2] 96.0 [28.1] 17.3	161.3 [47.3] 91.1 [26.7] 17.1	166.2 [48.7] 122.3 [35.8] 17.4	159.4 [46.7] 110.2 [32.3] 17.1	156.3 [45.8] 104.6 [30.7] 16.9	160.9 [47.2] 138.1 [40.5] 17.4	154.3 [45.2] 124.4 [36.5] 17.1	151.2 [44.3] 118.1 [34.6] 16.9
	125°F [51.7]°C	Total kBtu/h [kW] Sens kBtu/h [kW] Power	174.9 [51.3] 108.9 [31.9] 18.6	167.7 [49.2] 98.1 [28.8] 18.3	164.4 [48.2] 93.1 [27.3] 18.1	169.6 [49.7] 124.7 [36.5] 18.4	162.6 [47.7] 112.3 [32.9] 18.0	159.4 [46.7] 106.6 [31.2] 17.9	164.3 [48.2] 140.4 [41.1] 18.4	157.5 [46.2] 126.5 [37.1] 18.1	154.4 [45.3] 120.1 [35.2] 17.9

DR —Depression ratio
dbE —Entering air dry bulb
wbE—Entering air wet bulb

Total —Total capacity x 1000 Btu/h
Sens —Sensible capacity x 1000 Btu/h
Power —kW input

NOTES:
① When the entering air dry bulb is other than 80°F [27°C], adjust the sensible capacity from the table by adding [1.10 x CFM x (1 – DR) x (dbE – 80)].

[] Designates Metric Conversions

COOLING PERFORMANCE DATA—RACY2180

		ENTERING INDOOR AIR @ 80°F [26.7°C] dbE ①									
wbE		71°F [21.7°C]			67°F [19.4°C]			63°F [17.2°C]			
CFM [L/s]		6775 [3197]	5200 [2454]	4900 [2313]	6775 [3197]	5200 [2454]	4900 [2313]	6775 [3197]	5200 [2454]	4900 [2313]	
DR ①		0.05	0.09	0.12	0.05	0.09	0.12	0.05	0.09	0.12	
OUTDOOR DRY BULB TEMPERATURE °F [°C]	75°F [23.9]°C	Total kBtu/h [kW] Sens kBtu/h [kW] Power	200.9 [58.9] 119.2 [34.9] 10.6	260.3 [76.3] 138.1 [40.5] 17.0	188.4 [55.2] 101.6 [29.8] 10.3	186.5 [54.7] 140.0 [41.0] 10.4	176.8 [51.8] 122.7 [36.0] 10.2	174.9 [51.3] 119.3 [35.0] 10.1	176.2 [51.6] 165.2 [48.4] 10.2	167.0 [48.9] 144.7 [42.4] 10.0	165.2 [48.4] 140.8 [41.3] 9.9
	80°F [26.7]°C	Total kBtu/h [kW] Sens kBtu/h [kW] Power	203.8 [59.7] 122.7 [36.0] 11.6	261.5 [76.6] 140.8 [41.3] 18.8	191.2 [56.0] 104.7 [30.7] 11.2	189.4 [55.5] 143.5 [42.1] 11.4	179.5 [52.6] 125.7 [36.8] 11.1	177.7 [52.1] 122.4 [35.9] 11.0	179.1 [52.5] 168.7 [49.4] 11.2	169.8 [49.8] 147.8 [43.3] 10.9	168.0 [49.2] 143.9 [42.2] 10.9
	85°F [29.4]°C	Total kBtu/h [kW] Sens kBtu/h [kW] Power	205.5 [60.2] 124.9 [36.6] 12.6	262.8 [77.0] 143.6 [42.1] 20.5	192.7 [56.5] 106.5 [31.2] 12.2	191.1 [56.0] 145.7 [42.7] 12.4	181.1 [53.1] 127.6 [37.4] 12.1	179.2 [52.5] 124.2 [36.4] 12.0	180.8 [53.0] 170.9 [50.1] 12.2	171.3 [50.2] 149.7 [43.9] 11.9	169.5 [49.7] 145.7 [42.7] 11.9
	90°F [32.2]°C	Total kBtu/h [kW] Sens kBtu/h [kW] Power	205.9 [60.3] 125.7 [36.8] 13.7	264.1 [77.4] 146.4 [42.9] 22.3	193.1 [56.6] 107.2 [31.4] 13.3	191.5 [56.1] 146.5 [42.9] 13.5	181.5 [53.2] 128.3 [37.6] 13.2	179.6 [52.6] 124.9 [36.6] 13.1	181.2 [53.1] 171.7 [50.3] 13.4	171.7 [50.3] 150.4 [44.1] 13.0	169.9 [49.8] 146.4 [42.9] 13.0
	95°F [35]°C	Total kBtu/h [kW] Sens kBtu/h [kW] Power	205.0 [60.1] 125.1 [36.7] 14.9	265.4 [77.8] 149.1 [43.7] 24.0	192.3 [56.4] 106.6 [31.2] 14.5	190.6 [55.9] 145.9 [42.8] 14.8	180.7 [53.0] 127.8 [37.5] 14.4	178.8 [52.4] 124.3 [36.4] 14.3	180.3 [52.8] 171.1 [50.1] 14.6	170.9 [50.1] 149.9 [43.9] 14.2	169.1 [49.6] 145.8 [42.7] 14.1
	100°F [37.8]°C	Total kBtu/h [kW] Sens kBtu/h [kW] Power	202.9 [59.5] 123.1 [36.1] 16.2	266.6 [78.1] 151.9 [44.5] 25.8	190.3 [55.8] 105.0 [30.8] 15.7	188.4 [55.2] 143.9 [42.2] 16.0	178.6 [52.3] 126.1 [37.0] 15.6	176.7 [51.8] 122.7 [36.0] 15.6	178.1 [52.2] 169.1 [49.6] 15.9	168.8 [49.5] 148.1 [43.4] 15.5	167.1 [49.0] 144.2 [42.3] 15.4
	105°F [40.6]°C	Total kBtu/h [kW] Sens kBtu/h [kW] Power	199.4 [58.4] 119.7 [35.1] 17.6	267.9 [78.5] 154.7 [45.3] 27.6	187.0 [54.8] 102.1 [29.9] 17.1	185.0 [54.2] 140.5 [41.2] 17.4	175.4 [51.4] 123.1 [36.1] 17.0	173.5 [50.8] 119.8 [35.1] 16.9	174.7 [51.2] 165.7 [48.6] 17.2	165.6 [48.5] 145.2 [42.6] 16.8	163.9 [48.0] 141.3 [41.4] 16.7
	110°F [43.3]°C	Total kBtu/h [kW] Sens kBtu/h [kW] Power	194.7 [57.1] 115.0 [33.7] 19.1	269.2 [78.9] 157.4 [46.1] 29.3	182.6 [53.5] 98.1 [28.8] 18.5	180.3 [52.8] 135.8 [39.8] 18.9	170.9 [50.1] 119.0 [34.9] 18.4	169.1 [49.6] 115.8 [33.9] 18.3	170.0 [49.8] 161.0 [47.2] 18.7	161.1 [47.2] 141.1 [41.4] 18.2	159.4 [46.7] 137.3 [40.2] 18.1
	115°F [46.1]°C	Total kBtu/h [kW] Sens kBtu/h [kW] Power	188.8 [55.3] 108.9 [31.9] 20.6	270.5 [79.3] 160.2 [47.0] 31.1	177.0 [51.9] 92.8 [27.2] 20.0	174.3 [51.1] 129.7 [38.0] 20.4	165.2 [48.4] 113.6 [33.3] 19.9	163.5 [47.9] 110.6 [32.4] 19.8	164.0 [48.1] 154.9 [45.4] 20.2	155.5 [45.6] 135.7 [39.8] 19.7	153.8 [45.1] 132.0 [38.7] 19.6
	120°F [48.9]°C	Total kBtu/h [kW] Sens kBtu/h [kW] Power	181.5 [53.2] 101.4 [29.7] 22.2	271.7 [79.6] 163.0 [47.8] 32.8	170.2 [49.9] 86.5 [25.4] 21.5	167.1 [49.0] 122.2 [35.8] 22.0	158.4 [46.4] 107.0 [31.4] 21.5	156.7 [45.9] 104.2 [30.5] 21.4	156.8 [46.0] 147.4 [43.2] 21.9	148.6 [43.6] 129.1 [37.8] 21.3	147.0 [43.1] 125.7 [36.8] 21.2
125°F [51.7]°C	Total kBtu/h [kW] Sens kBtu/h [kW] Power	173.0 [50.7] 92.5 [27.1] 23.9	273.0 [80.0] 165.7 [48.6] 34.6	162.2 [47.5] 78.9 [23.1] 23.2	158.6 [46.5] 113.3 [33.2] 23.8	150.3 [44.1] 99.3 [29.1] 23.1	148.7 [43.6] 96.6 [28.3] 23.0	148.3 [43.5] 138.5 [40.6] 23.6	140.5 [41.2] 121.4 [35.6] 23.0	139.0 [40.7] 118.1 [34.6] 22.8	

DR —Depression ratio
dbE —Entering air dry bulb
wbE —Entering air wet bulb

Total —Total capacity x 1000 Btu/h
Sens —Sensible capacity x 1000 Btu/h
Power —kW input

NOTES:
① When the entering air dry bulb is other than 80°F [27°C], adjust the sensible capacity from the table by adding [1.10 x CFM x (1 – DR) x (dbE – 80)].

[] Designates Metric Conversions

COOLING PERFORMANCE DATA—RACY2240

		ENTERING INDOOR AIR @ 80°F [26.7°C] dbE ①									
wbE		71°F [21.7°C]			67°F [19.4°C]			63°F [17.2°C]			
CFM [L/s]		6775 [3197]	5200 [2454]	4900 [2313]	6775 [3197]	5200 [2454]	4900 [2313]	6775 [3197]	5200 [2454]	4900 [2313]	
DR ①		0.05	0.09	0.12	0.05	0.09	0.12	0.05	0.09	0.12	
O U T D O O R D R Y B U L B T E M P E R A T U R E ° F [° C]	75°F [23.9]°C	Total kBtu/h [kW] Sens kBtu/h [kW] Power	281.3 [82.4] 166.8 [48.9] 17.7	260.3 [76.3] 138.1 [40.5] 17.0	262.3 [76.9] 140.9 [41.3] 17.1	261.4 [76.6] 189.9 [55.7] 16.9	241.8 [70.9] 157.2 [46.1] 16.2	243.7 [71.4] 160.4 [47.0] 16.3	241.4 [70.8] 213.0 [62.4] 17.4	223.3 [65.4] 176.4 [51.7] 16.7	225.1 [66.0] 179.9 [52.7] 16.8
	80°F [26.7]°C	Total kBtu/h [kW] Sens kBtu/h [kW] Power	282.7 [82.9] 170.1 [49.9] 19.5	261.5 [76.6] 140.8 [41.3] 18.8	263.6 [77.3] 143.7 [42.1] 18.8	262.7 [77.0] 193.2 [56.6] 18.7	243.1 [71.2] 160.0 [46.9] 18.0	245.0 [71.8] 163.2 [47.8] 18.1	242.8 [71.2] 216.4 [63.4] 19.2	224.6 [65.8] 179.1 [52.5] 18.5	226.3 [66.3] 182.7 [53.5] 18.6
	85°F [29.4]°C	Total kBtu/h [kW] Sens kBtu/h [kW] Power	284.1 [83.3] 173.5 [50.8] 21.3	262.8 [77.0] 143.6 [42.1] 20.5	264.9 [77.6] 146.5 [42.9] 20.6	264.1 [77.4] 196.6 [57.6] 20.5	244.3 [71.6] 162.8 [47.7] 19.8	246.3 [72.2] 166.0 [48.7] 19.8	244.2 [71.6] 219.7 [64.4] 21.0	225.9 [66.2] 181.9 [53.3] 20.2	227.6 [66.7] 185.6 [54.4] 20.3
	90°F [32.2]°C	Total kBtu/h [kW] Sens kBtu/h [kW] Power	285.5 [83.7] 176.8 [51.8] 23.2	264.1 [77.4] 146.4 [42.9] 22.3	266.2 [78.0] 149.3 [43.8] 22.4	265.5 [77.8] 199.9 [58.6] 22.4	245.6 [72.0] 165.5 [48.5] 21.5	247.5 [72.5] 168.8 [49.5] 21.6	245.5 [72.0] 223.0 [65.4] 22.9	227.1 [66.6] 184.7 [54.1] 22.0	228.9 [67.1] 188.4 [55.2] 22.1
	95°F [35]°C	Total kBtu/h [kW] Sens kBtu/h [kW] Power	286.9 [84.1] 180.1 [52.8] 25.0	265.4 [77.8] 149.1 [43.7] 24.0	267.4 [78.4] 152.1 [44.6] 24.1	266.9 [78.2] 203.3 [59.6] 24.2	246.9 [72.4] 168.3 [49.3] 23.3	248.8 [72.9] 171.7 [50.3] 23.4	246.9 [72.4] 226.4 [66.4] 24.7	228.4 [66.9] 187.4 [54.9] 23.8	230.2 [67.5] 191.2 [56.0] 23.9
	100°F [37.8]°C	Total kBtu/h [kW] Sens kBtu/h [kW] Power	288.2 [84.5] 183.5 [53.8] 26.8	266.6 [78.1] 151.9 [44.5] 25.8	268.7 [78.8] 154.9 [45.4] 25.9	268.3 [78.6] 206.6 [60.6] 26.0	248.2 [72.7] 171 [50.1] 25.0	250.1 [73.3] 174.5 [51.1] 25.1	248.3 [72.8] 229.7 [67.3] 26.5	229.7 [67.3] 190.2 [55.7] 25.5	231.5 [67.8] 194.0 [56.9] 25.6
	105°F [40.6]°C	Total kBtu/h [kW] Sens kBtu/h [kW] Power	289.6 [84.9] 186.8 [54.7] 28.6	267.9 [78.5] 154.7 [45.3] 27.6	270.0 [79.1] 157.8 [46.2] 27.7	269.6 [79.0] 209.9 [61.5] 27.8	249.4 [73.1] 173.8 [50.9] 26.8	251.4 [73.7] 177.3 [52.0] 26.9	249.7 [73.2] 233.1 [68.3] 28.4	231.0 [67.7] 193.0 [56.6] 27.3	232.8 [68.2] 196.8 [57.7] 27.4
	110°F [43.3]°C	Total kBtu/h [kW] Sens kBtu/h [kW] Power	291.0 [85.3] 190.1 [55.7] 30.5	269.2 [78.9] 157.4 [46.1] 29.3	271.3 [79.5] 160.6 [47.1] 29.4	271.0 [79.4] 213.3 [62.5] 29.7	250.7 [73.5] 176.6 [51.8] 28.6	252.7 [74.1] 180.1 [52.8] 28.7	251.1 [73.6] 236.4 [69.3] 30.2	232.3 [68.1] 195.7 [57.4] 29.0	234.1 [68.6] 199.6 [58.5] 29.1
	115°F [46.1]°C	Total kBtu/h [kW] Sens kBtu/h [kW] Power	292.4 [85.7] 193.5 [56.7] 32.3	270.5 [79.3] 160.2 [47.0] 31.1	272.6 [79.9] 163.4 [47.9] 31.2	272.4 [79.8] 216.6 [63.5] 31.5	252.0 [73.9] 179.3 [52.5] 30.3	254.0 [74.4] 182.9 [53.6] 30.4	252.4 [74.0] 239.7 [70.3] 32.0	233.5 [68.4] 198.5 [58.2] 30.8	235.4 [69.0] 202.5 [59.3] 30.9
	120°F [48.9]°C	Total kBtu/h [kW] Sens kBtu/h [kW] Power	293.7 [86.1] 196.8 [57.7] 34.1	271.7 [79.6] 163.0 [47.8] 32.8	273.9 [80.3] 166.2 [48.7] 33.0	273.8 [80.2] 219.9 [64.4] 33.3	253.3 [74.2] 182.1 [53.4] 32.1	255.3 [74.8] 185.8 [54.5] 32.2	253.8 [74.4] 243.1 [71.2] 33.8	234.8 [68.8] 201.2 [59.0] 32.6	236.6 [69.3] 205.3 [60.2] 32.7
	125°F [51.7]°C	Total kBtu/h [kW] Sens kBtu/h [kW] Power	295.1 [86.5] 200.2 [58.7] 35.9	273.0 [80.0] 165.7 [48.6] 34.6	275.2 [80.7] 169.0 [49.5] 34.7	275.2 [80.7] 223.3 [65.4] 35.2	254.6 [74.6] 184.9 [54.2] 33.8	256.5 [75.2] 188.6 [55.3] 34.0	255.2 [74.8] 246.4 [72.2] 35.7	236.1 [69.2] 204.0 [59.8] 34.3	237.9 [69.7] 208.1 [61.0] 34.4

DR —Depression ratio
dbE —Entering air dry bulb
wbE—Entering air wet bulb

Total —Total capacity x 1000 Btu/h
Sens —Sensible capacity x 1000 Btu/h
Power —kW input

NOTES:
① When the entering air dry bulb is other than 80°F [27°C], adjust the sensible capacity from the table by adding [1.10 x CFM x (1 - DR) x (dbE - 80)].

[] Designates Metric Conversions

UNIT DIMENSIONS AND WEIGHTS 6.5, 7.5 & 10 TON (1 FAN) [22.9, 26.4 & 35.2 kW]

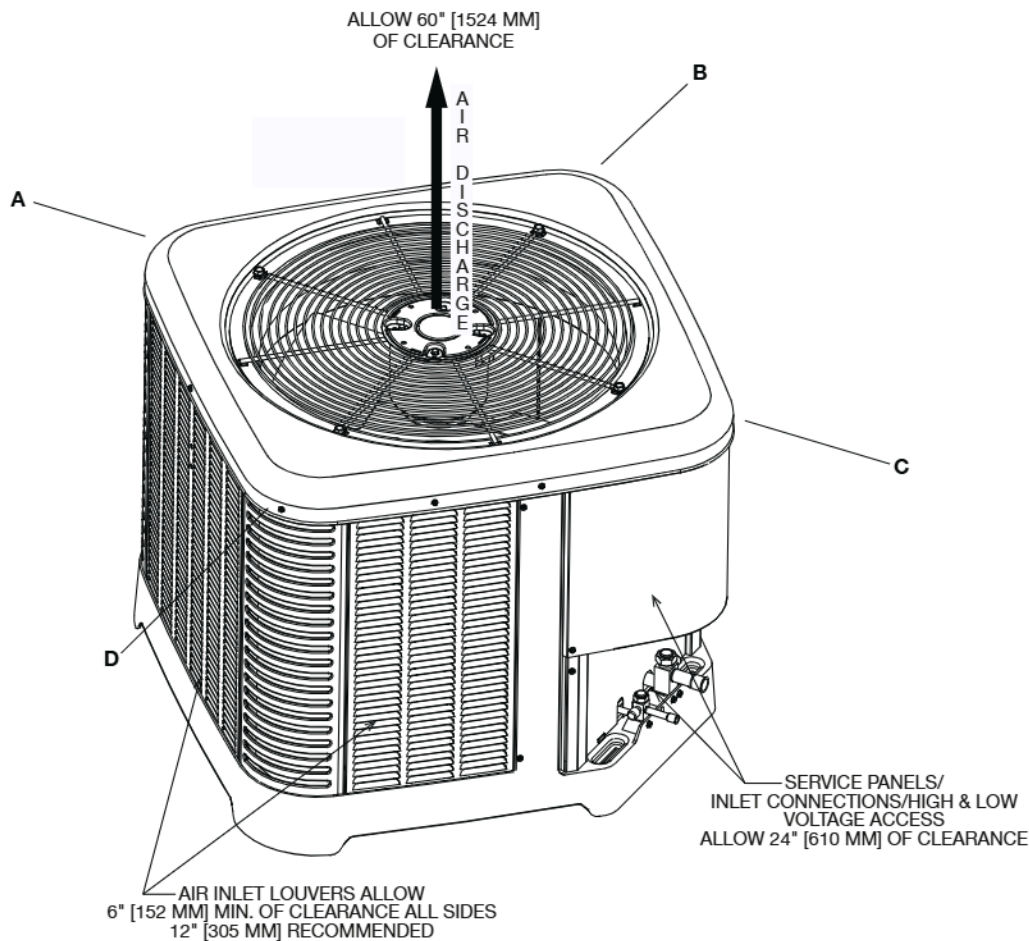

Illustration
ST-A1226-106-01

6.5, 7.5 & 10 TON (1 FAN) [22.9, 26.4 & 35.2 kW]

MODEL	TOTAL WEIGHT LBS. [kg]	CORNER WEIGHTS, LBS. [kg]			
		A	B	C	D
RACY2078	383 [174]	104 [47]	82 [37]	107 [49]	89 [40]
RACY2090	383 [174]	104 [47]	82 [37]	107 [49]	89 [40]
RACY2119	411 [186]	112 [51]	88 [40]	115 [52]	96 [44]

[] Designates Metric Conversions

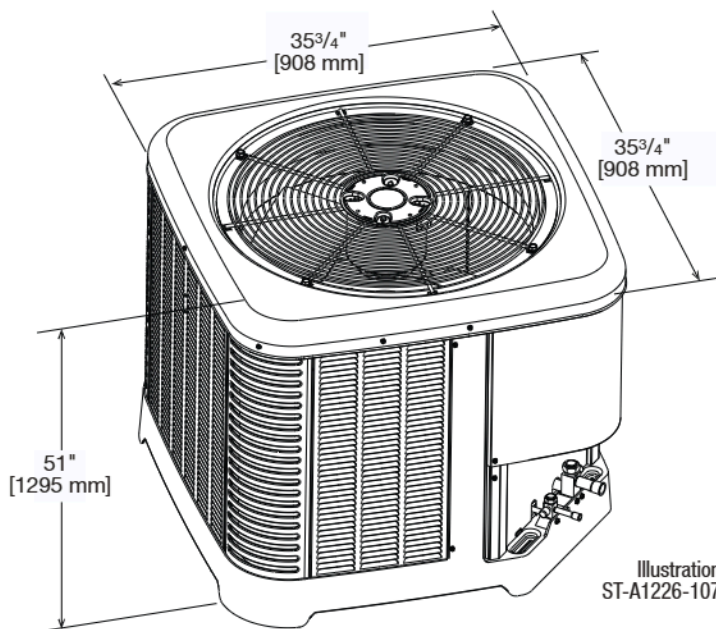

Illustration
ST-A1226-107

UNIT DIMENSIONS AND WEIGHTS 10 (2 FAN) & 12.5 TON [35.2 & 44.0 kW]

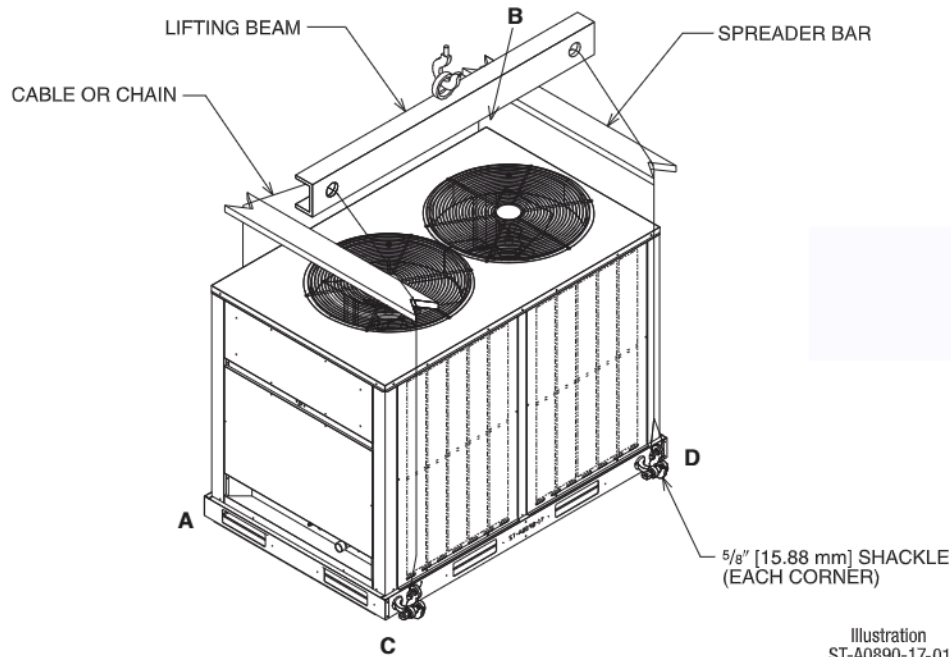
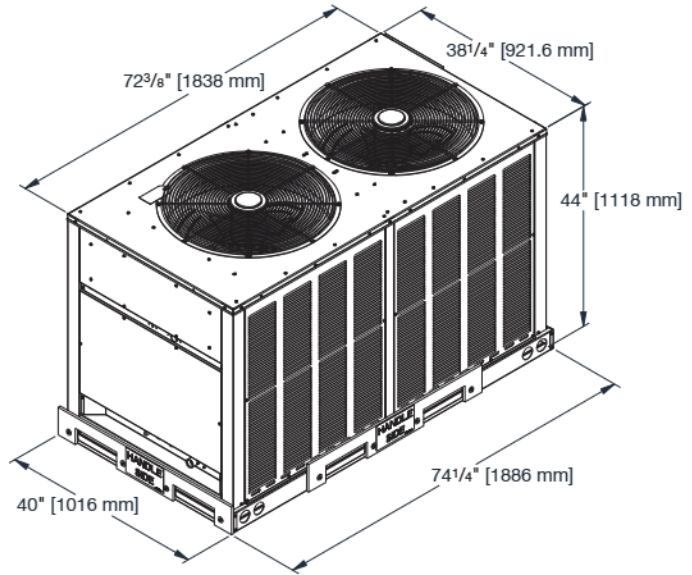
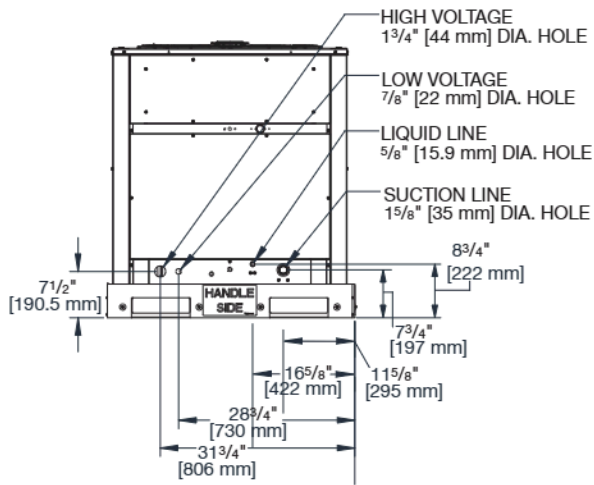

Illustration
ST-A0890-17-01

10 (2 FAN) & 12.5 TON [35.2 & 44.0 kW]

MODEL	TOTAL WEIGHT LBS. [kg]	CORNER WEIGHTS, LBS. [kg]			
		A	B	C	D
RACY2120	565 [256]	97 [44]	181 [82]	167 [76]	73 [33]
RACY2150	647 [293]	189 [86]	157 [71]	161 [73]	139 [63]

[] Designates Metric Conversions

UNIT DIMENSIONS AND WEIGHTS 15 & 20 TON [52.8 & 70.3 kW]

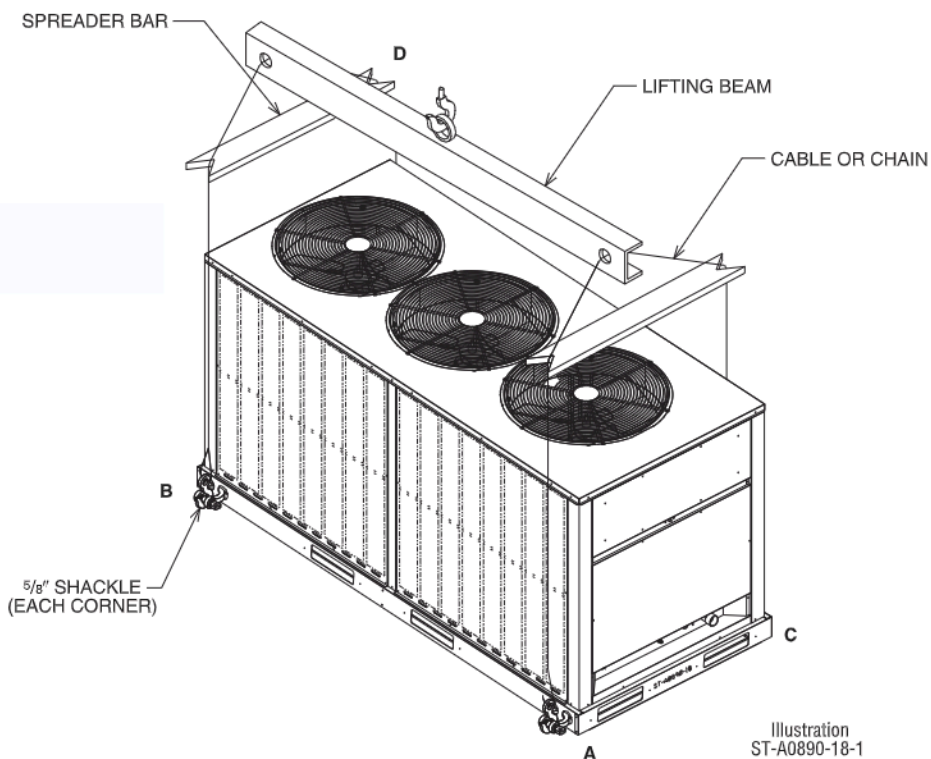
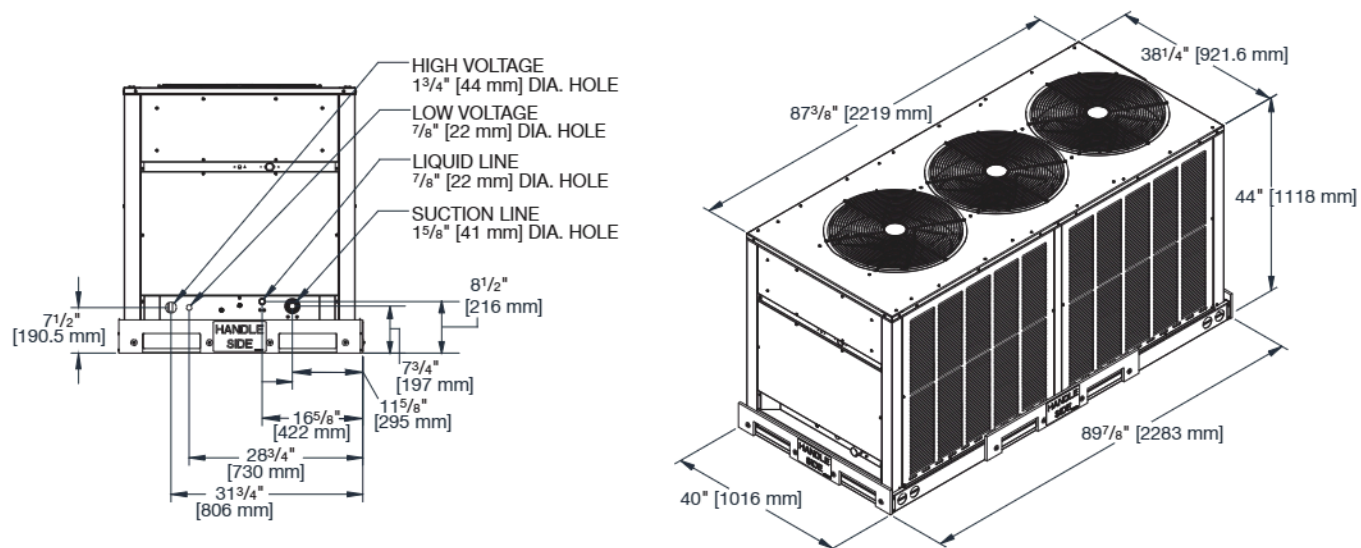

15 & 20 TON [52.7 & 70.3 kW]

CORNER WEIGHTS (LBS.) [kg]

MODEL	TOTAL WEIGHT LBS. [kg]	CORNER WEIGHTS, LBS. [kg]			
		A	B	C	D
RACY2180	832 [377]	240 [109]	183 [83]	167 [76]	242 [110]
RACY2240	926 [420]	308 [140]	128 [58]	161 [73]	328 [149]

[] Designates Metric Conversions

TYPICAL REFRIGERANT PIPING RECOMMENDATIONS

General Notes:

1. Vertical risers not to exceed 100 feet [30.48 m].
2. Locate the remote condensing unit and indoor air handler as close together as possible to minimize piping runs.
3. Remote condensing units are shipped with a nitrogen holding charge. Evacuate remote condensing unit before charging with refrigerant.
4. Runs between remote condensing unit and indoor air handler are not to exceed 200 feet [60.96 m] linear length.
5. The minimum velocity line (1500 FPM) [7.5 m/s] is recommended.
6. With the outdoor unit located below the indoor air handler, all vertical vapor lines must not exceed 1-1/8" [28.58 mm] O.D.
7. For suction pressure drop (PSIG) [6.9 kPa], multiply percent (%) loss by 1.8.
8. Size vapor lines for no more than a 5 PSIG [34.5 kPa] pressure drop (2.54% capacity loss) which corresponds to approximately 2°F [-16.7°C] loss.
9. All vertical vapor lines, 3 feet [0.91 m] or more in length, must have a short radius oil trap at the bottom of the riser.
10. All vertical vapor lines, 30 feet [9.14 m] or more in length, must have short radius oil traps every 15 to 20 feet [4.57 to 6.10 m] of run.

EQUIVALENT LENGTH (FT.) [m] OF STRAIGHT TYPE "L" TUBING FOR NON-FERROUS VALVES AND FITTINGS (BRAZED)				
TUBE SIZE INCHES [mm] O.D.	ANGLE VALVE	SHORT RADIUS ELL	LONG RADIUS ELL	TEE LINE FLOW
1/2 [12.7]	24 [7.32]	4.7 [1.43]	3.2 [0.98]	1.7 [0.52]
5/8 [15.88]	25 [7.62]	5.7 [1.74]	3.9 [1.19]	2.3 [0.70]
3/4 [19.05]	25 [7.62]	6.5 [1.98]	4.5 [1.37]	2.9 [0.88]
7/8 [22.23]	28 [8.53]	7.8 [2.38]	5.3 [1.62]	3.7 [1.13]
1 1/8 [28.58]	29 [8.84]	2.7 [0.82]	1.9 [0.58]	5.2 [1.59]
1 3/8 [34.93]	33 [10.06]	3.2 [0.98]	2.2 [0.67]	6.9 [2.10]

[] Designates Metric Conversions

INDOOR UNIT ABOVE OUTDOOR UNIT

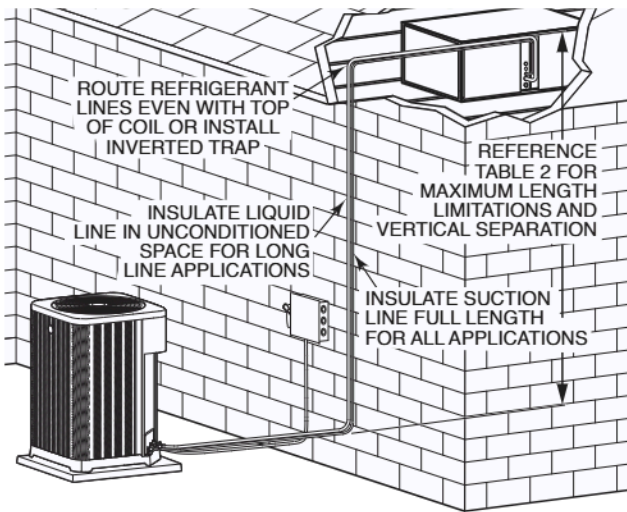

INDOOR UNIT BELOW OUTDOOR UNIT

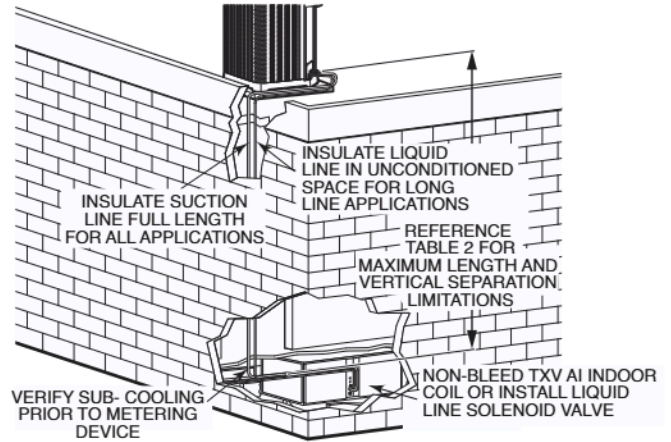

TYPICAL REFRIGERANT PIPING RECOMMENDATIONS

REQUIRED OUNCES. R-454B CHARGE PER FOOT [m] OF TUBING									
TUBE SIZE		LIQUID TUBE		VAPOR TUBE		TOTAL		INTERNAL VOLUME	
OD (IN)	OD (MM)	OZ/FT	KG/M	OZ/FT	KG/M	OZ/FT	KG/M	ft ³ /ft	M ³ /M
3/8	9.5	0.5	0.05	0.0	0.00	0.5	0.05	0.000555	0.000048
1/2	12.7	1.0	0.09	0.0	0.00	1.0	0.09	0.00108	0.0000929
5/8	15.9	1.5	0.14	0.1	0.00	1.6	0.15	0.00173	0.000149
3/4	19.1	2.2	0.21	0.1	0.01	2.3	0.21	0.00248	0.000214
7/8	22.2	3.1	0.29	0.1	0.01	3.2	0.30	0.00343	0.000296
1	25.4	4.0	0.37	0.1	0.01	4.2	0.39	0.0045	0.000389
1 1/8	28.6	5.2	0.49	0.2	0.02	5.4	0.50	0.00585	0.000503
1 1/4	31.8	6.5	0.60	0.2	0.02	6.7	0.62	0.00721	0.000623
1 3/8	34.9	7.3	0.68	0.2	0.02	7.6	0.70	0.008165	0.000758595
1 1/2	38.1	9.4	0.87	0.3	0.03	9.7	0.90	0.0105	0.00091
1 5/8	41.3	11.2	1.04	0.4	0.03	11.6	1.08	0.0125	0.00108
2 1/8	54.0	19.5	1.82	0.6	0.06	20.2	1.88	0.0218	0.00188

Quantities based on 110°F liquid and 45°F vapor.

Guide Specifications RACY2-078–240

You may copy this document directly into your building specification. This specification is written to comply with the 2016 version of the “master format” as published by the Construction Specification Institute. www.csinet.org.

AC CONDENSING UNIT

HVAC Guide Specifications

Size Range: 6.5 to 20 Nominal Tons

1.01 Quality Assurance:

- A. Unit shall be rated in accordance with AHRI Standard 340/360.
- B. Unit construction shall comply with ANSI/ASHRAE 15 safety code latest revision and comply with NEC.
- C. Unit shall be constructed in accordance with UL 60335-2-40 standard and shall carry the UL label.
- D. Unit cabinet shall be capable of withstanding 500 hour salt spray exposure per ASTM B117 (scribed specimen).
- E. Air-cooled condenser coils for hermetic scroll compressor units shall be leak tested at 250 psig, and pressure tested at 450 psig.
- F. Unit shall be subjected to run test on the assembly line.
- G. Unit meets ASHRAE 90.1 2022 minimum efficiency requirements.

1.02 Manufacturer Qualifications:

- A. Unit shall be manufactured in a facility registered to ISO 9001:2015 manufacturing quality standard.

1.03 Installer Qualifications:

- A. The installer shall be trained to install and service equipment with A2L refrigerants.

1.04 Delivery, Storage, and Handling:

- A. Unit shall be shipped as single package only, and shall be stored and handled according to unit manufacturer's recommendations.
- B. Unit shall be stored and handled per manufacturer's recommendations.
- C. Refer to the manufacturer's installation and operation manual for guidance on how to properly lift the unit.
- D. Unit shall only be stored or positioned in the upright position.

1.05 Unit Cabinet:

- A. Unit cabinet shall be constructed of galvanized steel and coated with a pre-painted baked enamel finish.
- B. A heavy-gauge roll-formed perimeter base rail with forklift slots and lifting holes shall be provided to facilitate rigging.
 - i. Unit cabinet exterior paint shall be pre-painted steel.
- C. No base pan penetration, other than those authorized by the manufacturer, is permitted.
 - i. Heavy-Gauge Base Pan and Base Rail 120-240:
 - a. Unit shall have base rails on a minimum of 4 sides.
 - b. Holes shall be provided in the base rails for rigging shackles to facilitate maneuvering and overhead rigging.
 - c. Holes shall be provided in the base rail for moving the rooftop for fork truck.
 - d. Base rail shall be a minimum of 14 gauge thickness.
 - ii. Plastic Base Pan 078, 090, and 119:
 - a. Shall be a sloped condensate drain pan made of a non-corrosive material and be removable for cleaning.
 - b. Shall comply with ASHRAE Standard 62.
 - c. Shall be able to be easily removed.
 - iii. Top panel 078, 090, and 119:
 - a. Top panel is removable for service access.
 - iv. Electrical Connections:
 - a. All unit power wiring shall enter unit cabinet a single, factory-prepared, continuous raised flange opening in the base pan.
 - 1. Thru-the-base capability for 078, 090, and 119: Electrical connections are located close to the ground for a neat-looking installation.
 - v. Component access panels (standard):
 - a. Cabinet panels shall be easily opened for servicing.
 - b. Control box as well as the compressor and other refrigerant controls being accessible through access panels. Control box may be open without affecting the normal operation of the unit. Condenser fan motors are accessible by removing wire grilles.
 - c. Fasteners shall be permanently attached.

1.06 Condenser Fans:

- A. Condenser fans shall be direct driven, propeller type, discharging air vertically upward.
- B. Fan blades shall be balanced.
- C. Condenser fan discharge openings shall be equipped with PVC-coated steel wire safety guards.
- D. Condenser fan and motor shaft shall be corrosion resistant.
- E. Condenser fan motors are accessible by removing wire grilles.

1.07 Refrigerant Components:

- A. The refrigerant circuit shall include the following control, safety, and maintenance features:
 - i. Refrigerant filter drier.
 - ii. Service gauge connections on suction and discharge lines.
 - iii. External pressure gauge ports allows pressures to be checked on the side, without removing access panel.

1.08 Compressors:

- A. Compressor shall be of the hermetic scroll type.
- B. Compressor shall be mounted on rubber grommets.
- C. Compressors shall include overload protection.
- D. Compressors shall be equipped with a crankcase heater.
- E. Compressor shall be equipped with internal high pressure and high temperature protection.

1.09 Condenser Coils:

- A. Standard Aluminum Fin - Copper Tube Coils:
 - i. Condenser coils shall have aluminum lanced plate fins mechanically bonded to seamless internally grooved copper tubes with all joints brazed.
 - ii. Condenser coils shall be leak tested to 250 psig, pressure tested to 450 psig, and qualified to UL 60335-2-40.

1.10 Controls and Safeties:

- A. Minimum control functions shall include:
 - i. Control wire terminal blocks.
 - ii. Compressor lockout on auto-reset safety until reset from thermostat.
 - iii. Minimum safety devices which are equipped with automatic reset (after resetting first at thermostat), shall include:
 - a. High discharge pressure cutout.
 - b. Low pressure cutout.
- B. Turn off electric power at the fuse box or service panel before making any electrical connections.
- C. The unit must be permanently grounded.
- D. Components are not compatible between different refrigerants. Do not use R-410A service equipment or components on R-454B equipment. System or part failure could occur.

1.11 Operating Characteristics:

- A. Standard unit shall be capable to operate up to 125.6°F (52°C) and down to 40°F (4°C).
- B. Compressor with standard controls shall be capable of operation down to 50°F (10°C), ambient outdoor temperatures. Low ambient accessory kit is necessary if mechanically cooling at ambient temperatures to 0°F (-17.7°C).

1.12 Electrical Requirements:

- A. Nominal unit electrical characteristics:
 - i. Shall be 208/230v, 3-ph, 60 Hz. The unit shall be capable of satisfactory operation within voltage limits of 187v to 253v.
 - ii. Shall be 460v, 3-ph, 60 Hz. The unit shall be capable of satisfactory operation within voltage limits of 414v to 506v.
 - iii. Shall be 575v, 3-ph, 60 Hz. The unit shall be capable of satisfactory operation within voltage limits of 514v to 610v.
- B. Unit control circuit shall contain a 24-v transformer for unit control.
- C. Main power supply voltage, phase, and frequency must match those required by the manufacturer.

1.13 Special Features:

- A. Low-Ambient Temperature Control:
 - i. A low-ambient temperature control shall be available as a factory-installed option or as a field-installed accessory. This low-ambient control shall regulate the speed of the condenser-fan motors in response to the saturated condensing temperature of the unit. The control shall maintain correct condensing pressure opens at 250 psig and closes at 450 psig. Allows unit to operate to 0°F.
- B. Condenser Coil Grille: Grille shall add decorative appearance to unit and protect condenser coil from large objects and vandalism.



GENERAL TERMS OF LIMITED PARTS WARRANTY*

Rheem will furnish a replacement for any part of this product which fails in normal use and service within the applicable periods stated, in accordance with the terms of the limited warranty.

***For Complete Details of the Limited Warranty, Including Applicable Terms and Conditions, See Your Local Installer or Contact the Manufacturer for a Copy.**

Compressor
(Commercial Applications)Five (5) Years

Parts
(Commercial Applications)One (1) Year

Before proceeding with installation, refer to installation instructions packaged with each model, as well as complying with all Federal, State, Provincial, and Local codes, regulations, and practices.

© 2025 Rheem Manufacturing Company. Rheem trademarks owned by Rheem Manufacturing Company.

In keeping with its policy of continuous progress and product improvement, Rheem reserves the right to make changes without notice.

5600 Old Greenwood Road
Fort Smith, Arkansas 72908 • www.rheem.com

125 Edgeware Road, Unit 1
Brampton, Ontario • L6Y 0P5