



Air Conditioning & Heating



Goodman *GTST* Connected Thermostat Installation & Commissioning

Technical Training Module TRC-13



Skyport Home



Disclaimer

This material provides technical information that is to only be used by appropriately trained and certified HVAC-R installers and technicians who have agreed to the terms and conditions available here at <https://www.daikincity.com/DaikinCityB2BTermsOfUse.html>. If you have not agreed to these terms and conditions, you may not use or view this material, and you assume responsibility for any injury or property, system or equipment damage which may result. If you have agreed to these terms, you also agree, by viewing or using this material, that this material, by its nature, cannot include a discussion of everything necessary to effect a proper installation or repair of HVAC-R equipment, nor can it address every possible scenario or environment a technician or installer may encounter. Accordingly, this material should not be considered as recommendations for best practices and will not be considered installation or repair instructions to the extent of any conflict with Daikin- or Goodman-issued manuals and specifications, or industry standards and regulations. Each installer or technician remains fully responsible for ensuring proper installation or repair of the HVAC-R equipment being worked on, and you remain fully responsible for any injury or property, system or equipment damage which may result from your installation. ©2026 Daikin Comfort Technologies North America, Inc., all rights reserved; recording, copying, or distribution of this material is prohibited without express written permission from Daikin.



Agenda

Goodman *GTST* Connected Thermostat

System Configurations

Installing Goodman *GTST* Connected Thermostat

Commissioning Goodman *GTST* Connected Thermostat with Wi-Fi (*SkyportCare*-recommended)

Commissioning Goodman *GTST* Connected Thermostat without Wi-Fi

SkyportHome App

Goodman *GTST Connected Thermostat*

- Small footprint design.
- Commissioning and setup can be accomplished with the *SkyportCare* app.
 - The end user will be able to control the system remotely through the *SkyportHome* app.
 - Additional option for commissioning is through the Goodman *GTST Connected Thermostat* thermostat buttons.
 - **Limited features.**
- Open API for integration into most home control systems, such as Crestron® and Control4®.



SkyportCare



SkyportHome

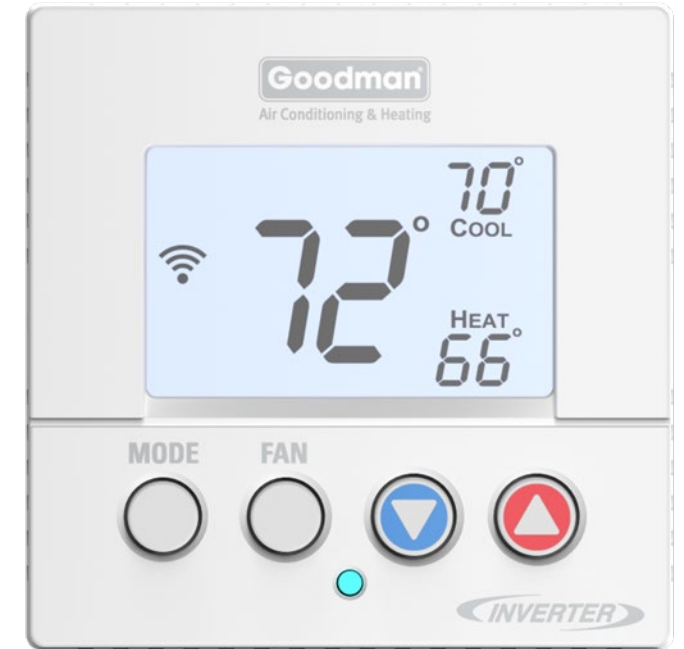

Goodman *GTST Connected Thermostat* Interface

- Pressing or holding down a button or combination of buttons navigates the user through menus to view/adjust settings.

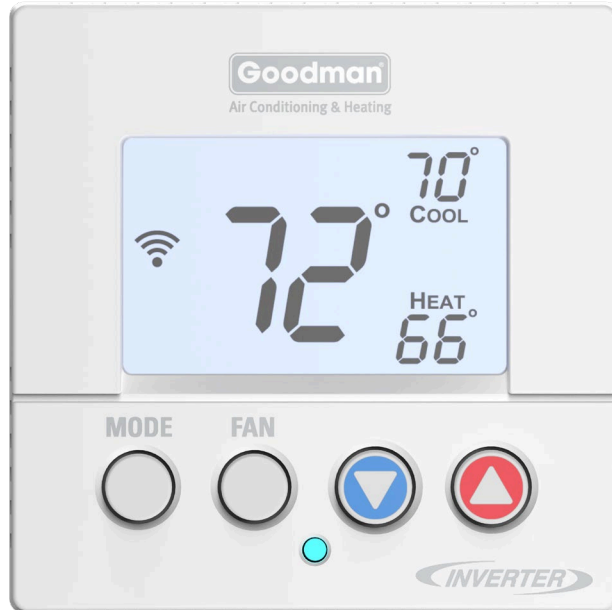

- Navigation through menus and adjusting can also be made using tactile gestures on the *SkyportHome* application from your mobile device.

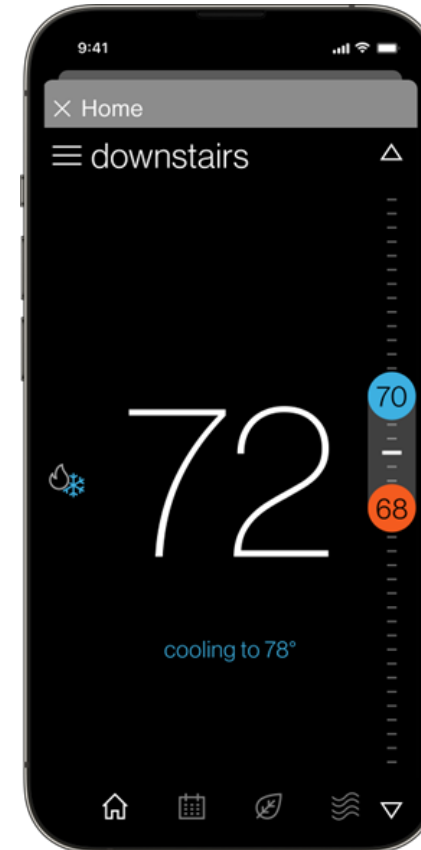

- Goodman GTST Connected Thermostat messaging updates, confirms, and informs about selections you make during set-up and operation.
- There are four types of messages:
 - Status
 - Blue-cooling
 - Red- heating
 - Alerts
 - A critical alert is displayed as a message until resolved by the dealer and dismissed by putting the unit in “OFF” mode and then back into an operation mode.
 - Reminders and Prompts
 - Learn more/tips (App. Only)

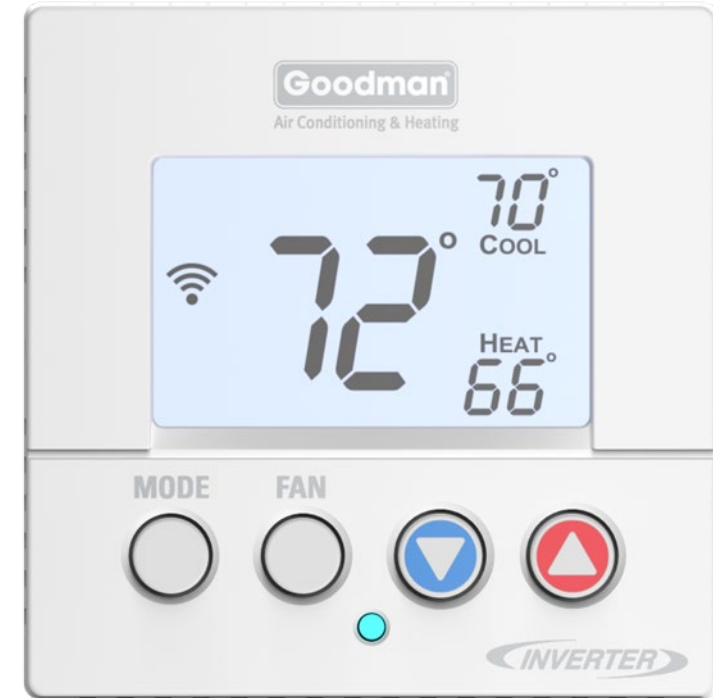

- Quick reference cards are packaged with the thermostat to help answer questions during the installation and commissioning.

Dealers

Install the thermostat

Use the supplied screws to secure the terminal plate to the wall.

After connecting the wires, place thermostat over guide pins and press firmly until it snaps into place.

Once connected to power, commission the system. Scan the QR code to download the Goodman Installer Mobile App and follow the on-screen commissioning instructions.

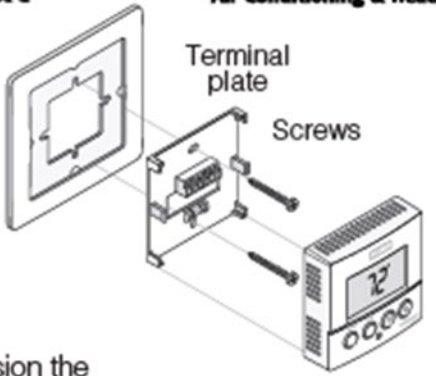

Trim plate (optional)

Terminal plate

Screws

Thermostat

Get help at goodmanmfg.com



Scanning the QR code on the **bottom right** corner will link you to a website related to the title of the card.

Agenda

Goodman *GTST* Connected Thermostat

System Configurations

Installing Goodman *GTST* Connected Thermostat

Commissioning Goodman *GTST* Connected Thermostat with Wi-Fi (*SkyportCare*-recommended)

Commissioning Goodman *GTST* Connected Thermostat without Wi-Fi

SkyportHome App

Valid System Configurations

Communicating indoor

- Air handler.
- Furnace.
- EEV coil.



Communicating outdoor

- Heat pump.
- Air Conditioning.



- Always verify the system on Partnerlink (system configurator) or contact your local distributor

Agenda

Goodman *GTST* Connected Thermostat System Configurations

Installing Goodman *GTST* Connected Thermostat

Commissioning Goodman *GTST* Connected Thermostat
with Wi-Fi (*SkyportCare*-recommended)

Commissioning Goodman *GTST* Connected Thermostat
without Wi-Fi

SkyportHome App

Installing Goodman *GTST Connected Thermostat*

- DO NOT install the thermostat where it can be affected by:
 - Drafts or dead spots behind doors and in corners.
 - Hot or cold air from ducts or ceiling fans.
 - Radiant heat from the sun or appliances.
 - Concealed pipes and chimneys.
 - Unheated (uncooled) areas such as an outside wall.

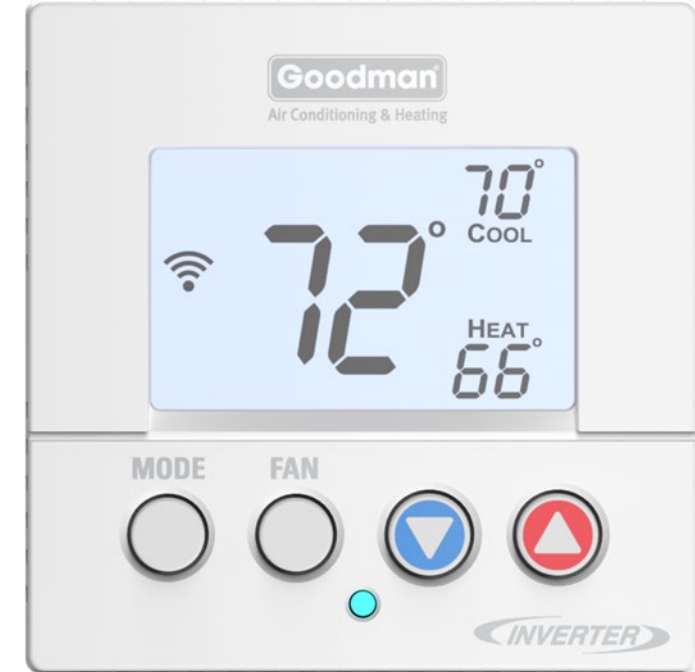

Mount the thermostat to be:

- Leveled.
- Approximately 5' from the floor.
- On an interior wall using the included screws.

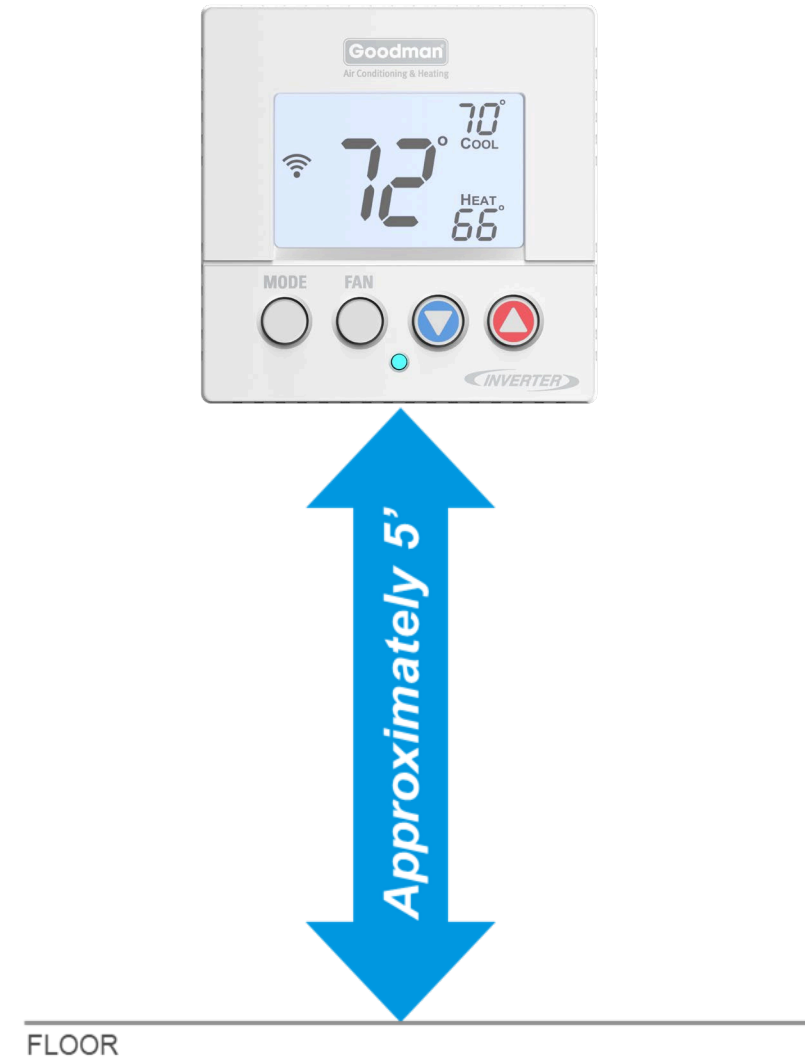
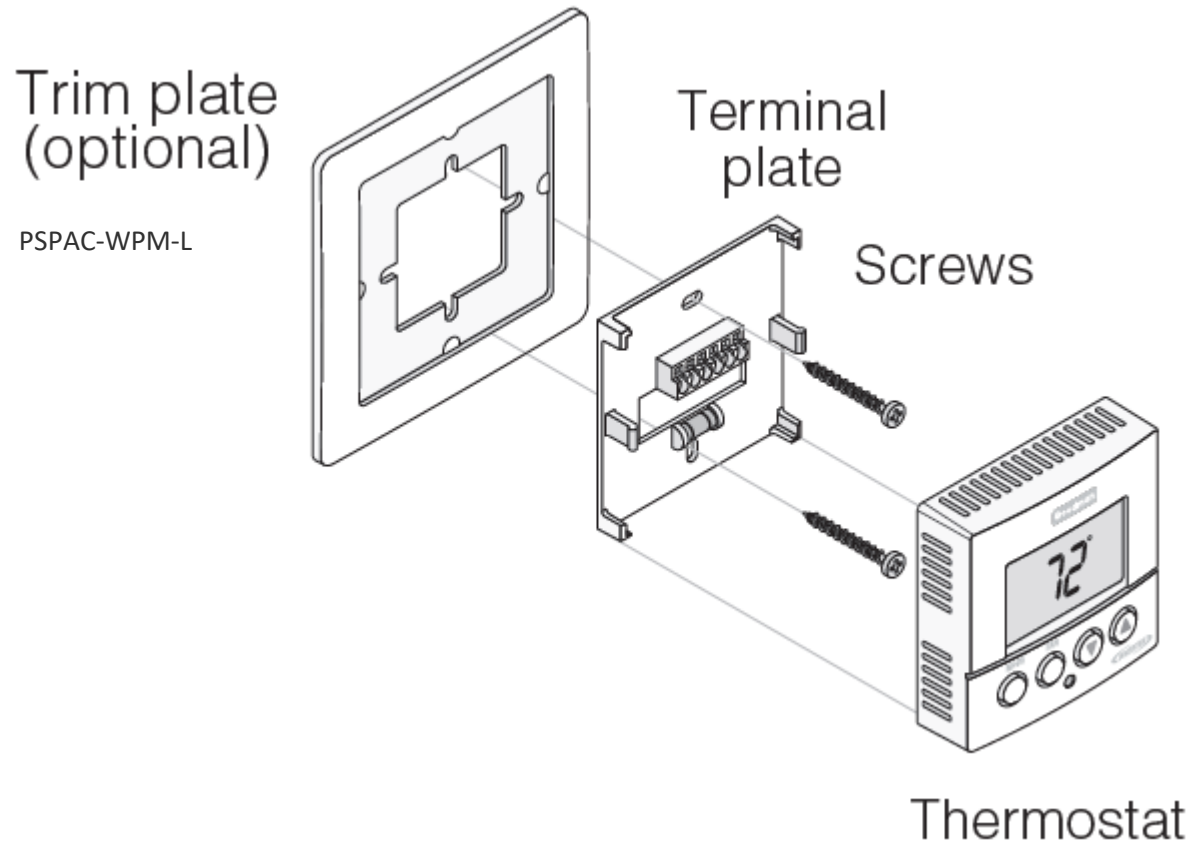

Wiring Thermostat To Communicating Systems

- Maximum wire distance between the Thermostat and the indoor unit should not exceed **125 feet using 18-gauge wire**. Standard non-stranded thermostat wire is acceptable.
- **Check for proper voltage before and after wiring is installed.**
 - 0.6VDC between Data 1 and 2
- Wiring communicating indoor unit to communicating outdoor units.
 - Connect **1, 2, C and R** from the *GTST Connected Thermostat*, to **1, 2, C and R** at the **indoor** unit.
 - Connect wires **1 and 2** from the **indoor** unit to **1 and 2** at the **outdoor** unit.
- **Note:** The Goodman *GTST Connected Thermostat* is labeled **1, 2, C, R**. **If wired incorrectly, you will receive a communication error, or your equipment may not be recognized and displayed.**

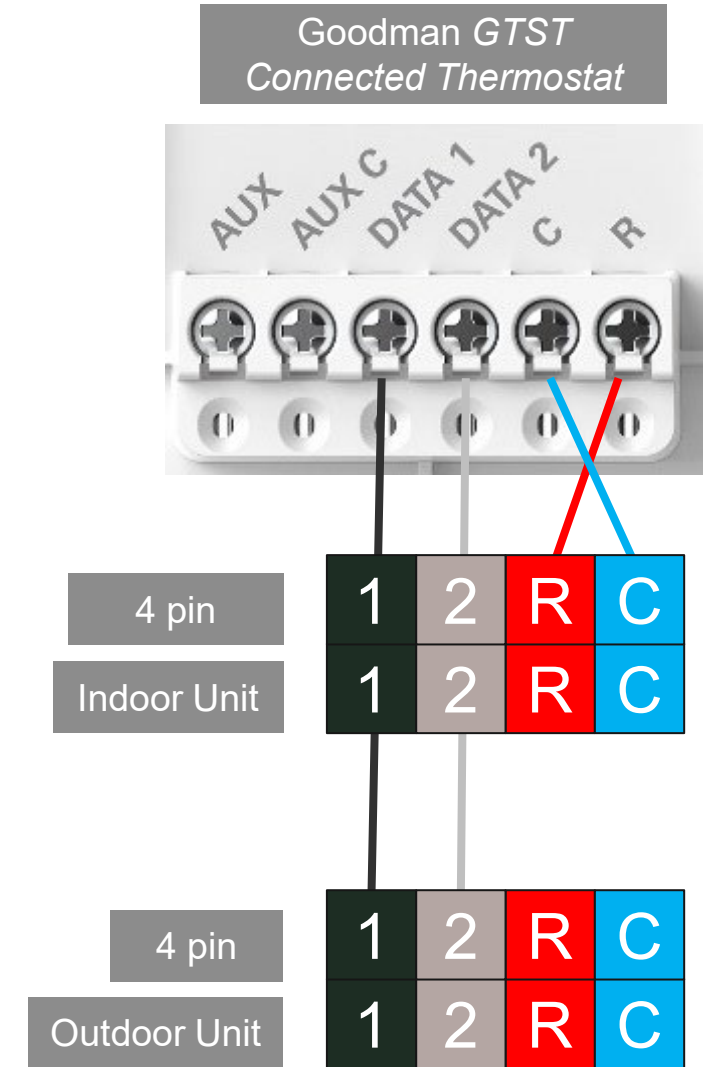

Aux Wiring

- The thermostat's Aux output is a dry contact that closes the connection to turn on the Aux equipment.
- A 24VAC+ control signal must be routed through the aux contact of the thermostat.

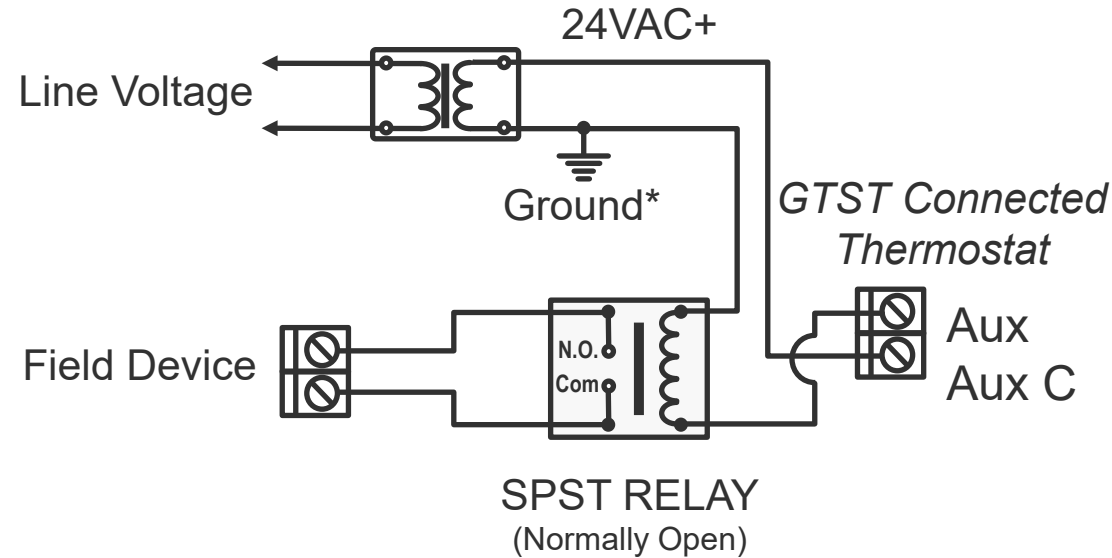

*Transformer must be grounded on the common side. Aux will not work with a floating transformer.

Note: It is recommended to use a minimum of 18-gauge wire. Standard non-stranded thermostat wire is acceptable.
Maximum operating length of wire is 125 ft.

Use The Coolcloud™ App. To Verify Furnace Firmware

- The *GTST Connected Thermostat* must be utilized when setting up communication.

Note: Side discharge systems are not *Comfortbridge* controlled. If wired to a *Comfortbridge* indoor unit, the indoor unit requires a critical OTA update. The installer must complete the update using the Cool Cloud application.

- **Do not energize the controller until you have verified the critical OTA is complete.**

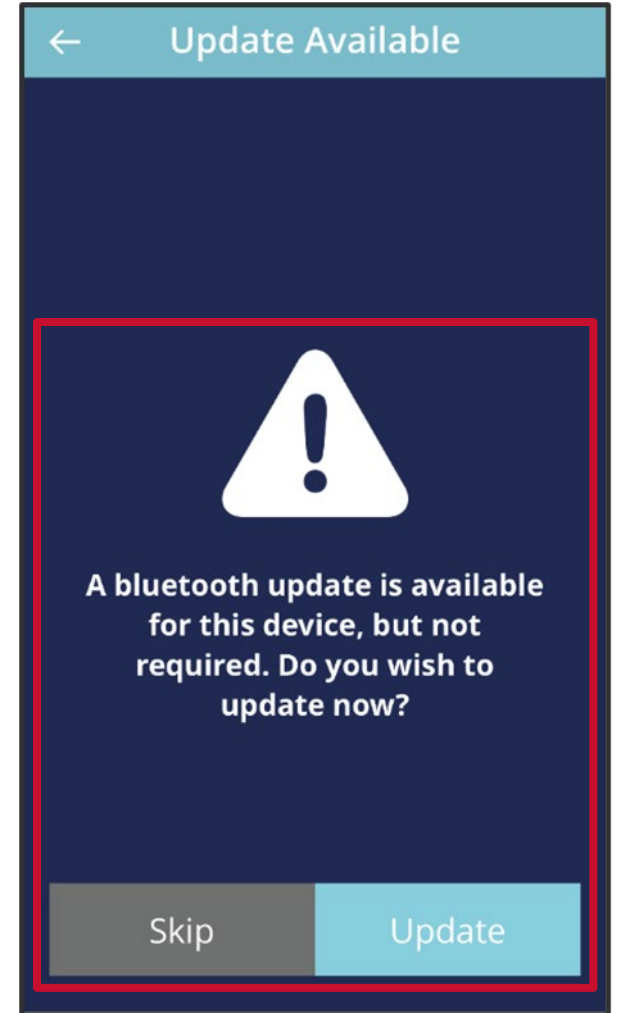

Software updates

- Once paired, available software updates will be displayed.
- Mandatory updates are required before moving forward.
- Optional updates can be downloaded or skipped.

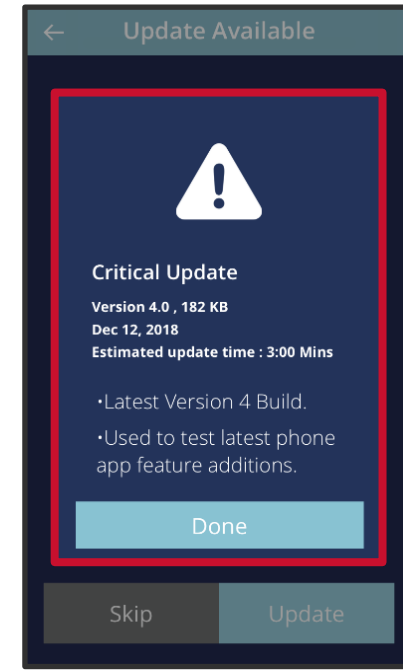
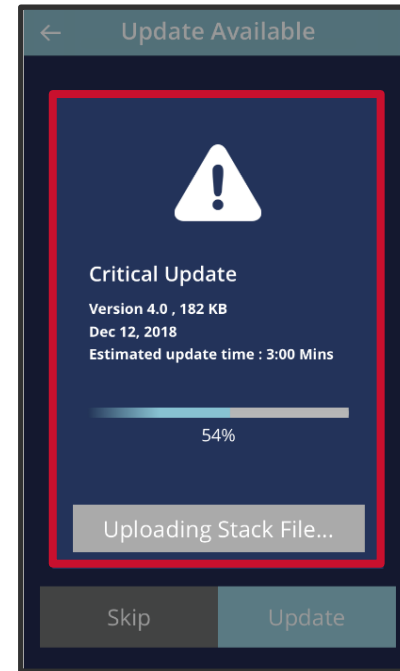
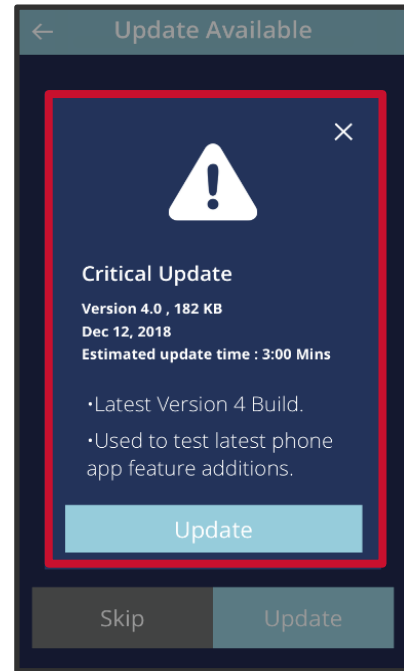
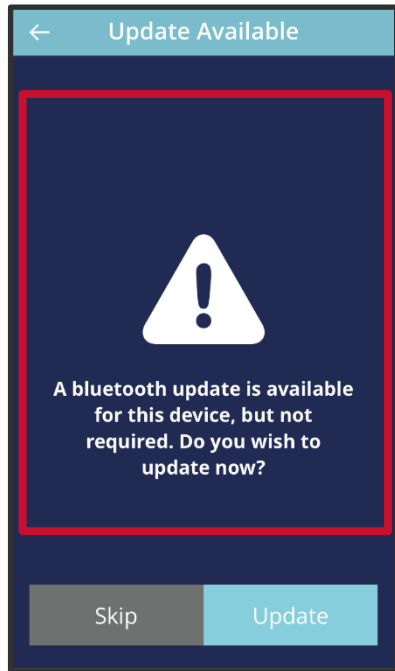

Permissions required by application

- Access To Photos

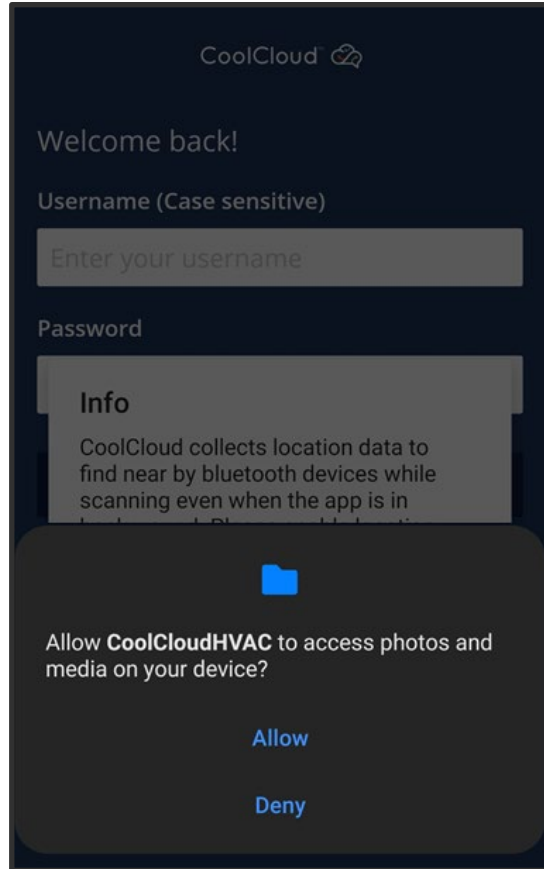

- Bluetooth Scanning

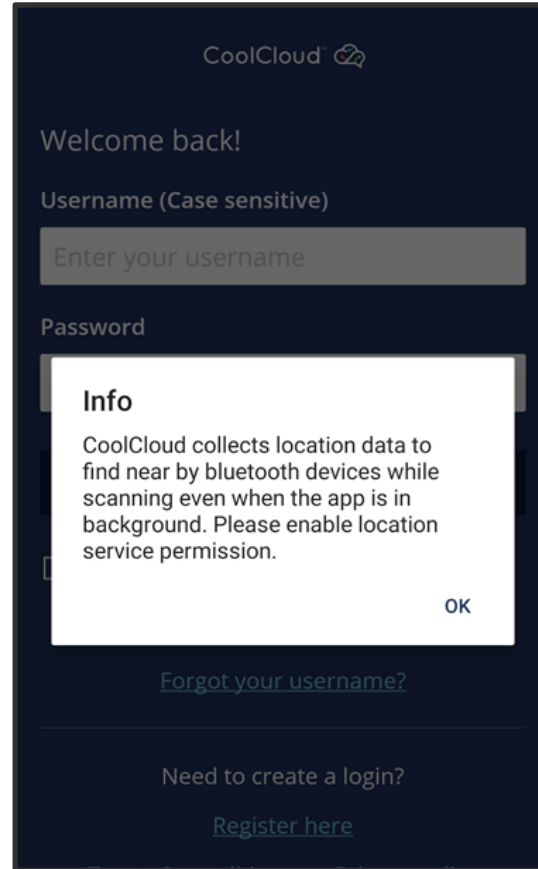

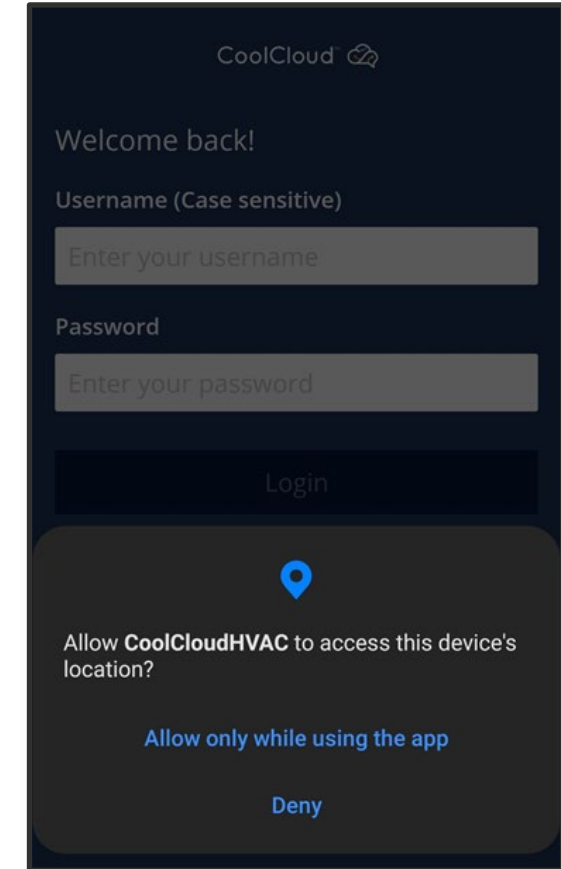

- Device Location

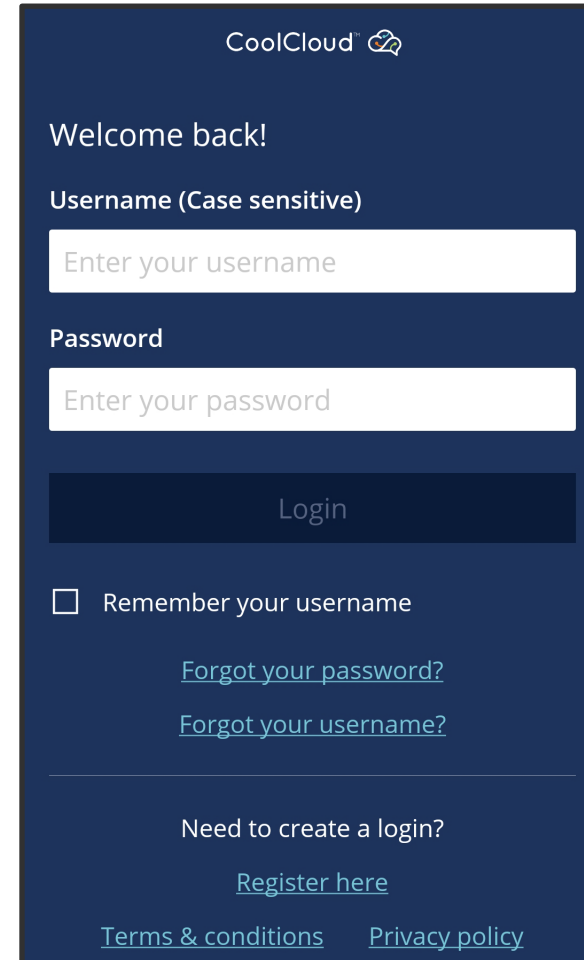

Login and registration screens

- Log in where you have a strong cell signal or are on an available Wi-Fi network.
- Create an account to get started.
- New users will first have to register for an account by providing registration information.
 - Note: Username information cannot be edited once selected by the user.
- If a user would like to make changes to the account information a new account will need to be created.



CoolCloud™ 

Welcome back!

Username (Case sensitive)

Password

Login

Remember your username

[Forgot your password?](#)

[Forgot your username?](#)

Need to create a login?

[Register here](#)

[Terms & conditions](#) [Privacy policy](#)

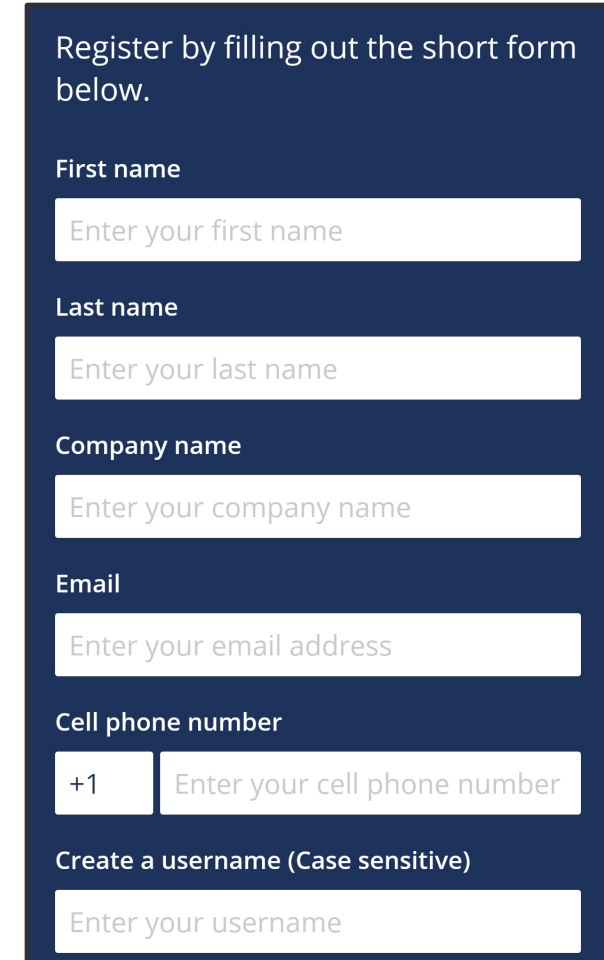

Register by filling out the short form below.

First name

Last name

Company name

Email

Cell phone number

Create a username (Case sensitive)

Connecting to equipment

- Move to proximity of the equipment, boot up the app and the indoor equipment should appear on the device screen.
- Random **Bluetooth**® equipment in range may also appear and can simply be ignored.
- If the equipment being searched for does not appear choose *Refresh* in the upper right.
- A unit may not show up if:
 - It is out of **Bluetooth** range
 - Another user is connected to the same **Bluetooth** device
 - The unit is not powered on
- Tap the desired equipment to begin the connection steps.
- Pressing *Logout* returned the user to the previous log in screen.

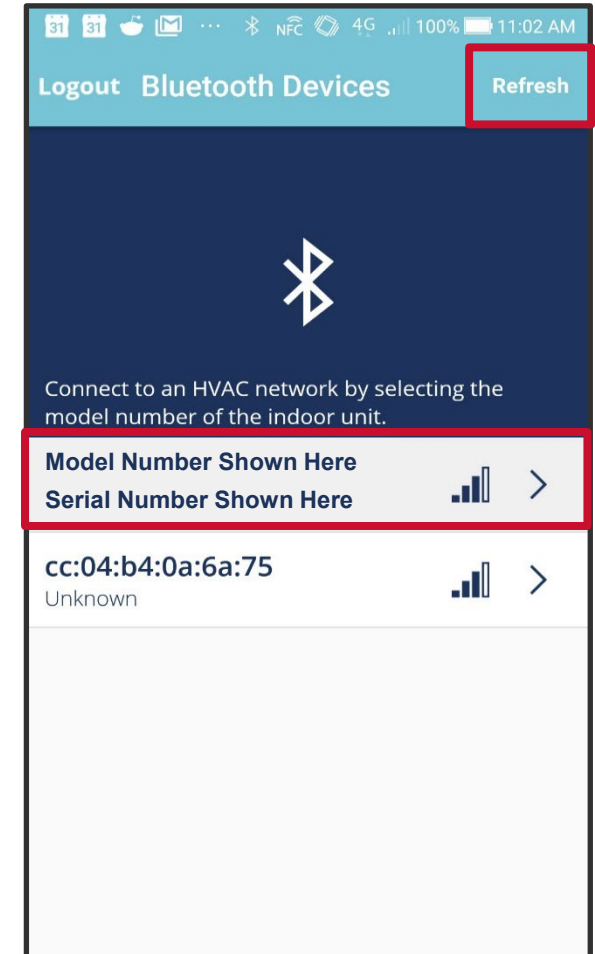

Pair device by code

- Allows the user to enter the three-digit code from the circuit board's three 7-segment displays.
- **Note:** The user cannot pair the device using the Amana Brand Smart Thermostat

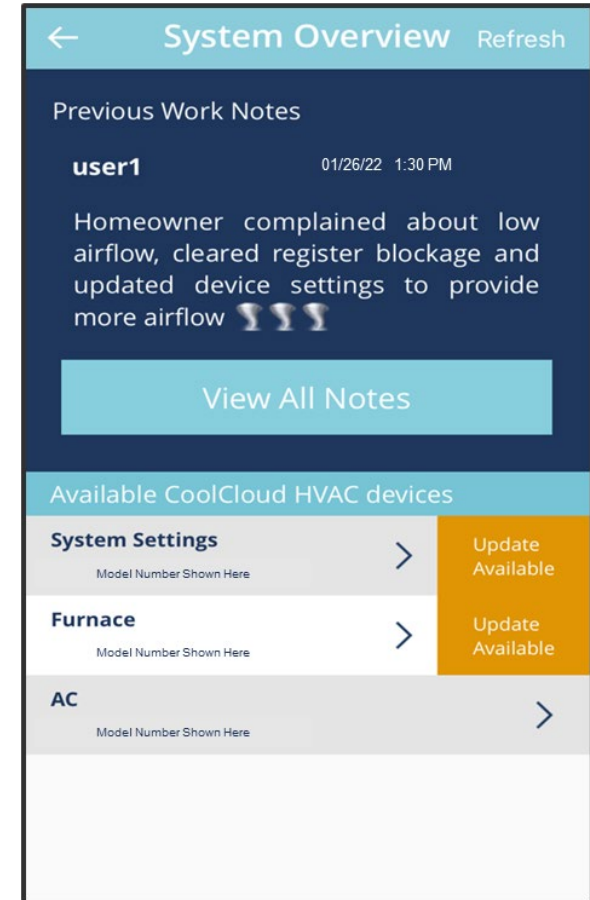

Pairing to indoor equipment using circuit board code

- You will be prompted for a 3-digit access code shown on the three seven segment displays.

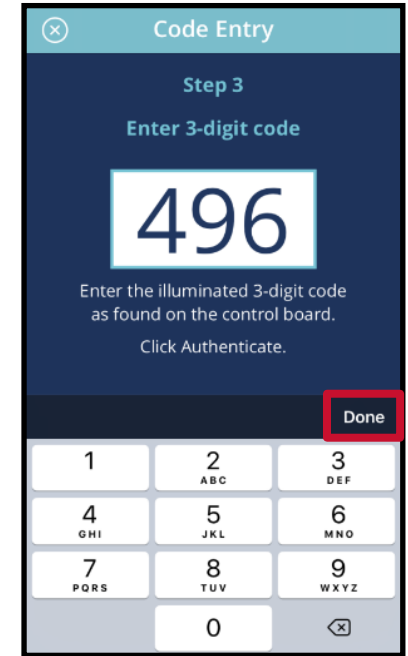
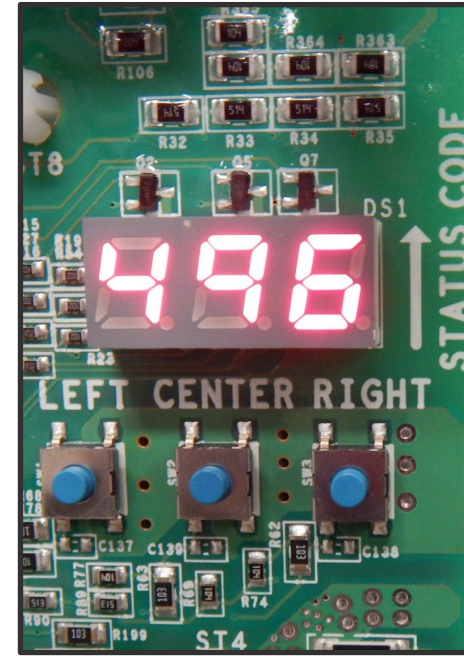
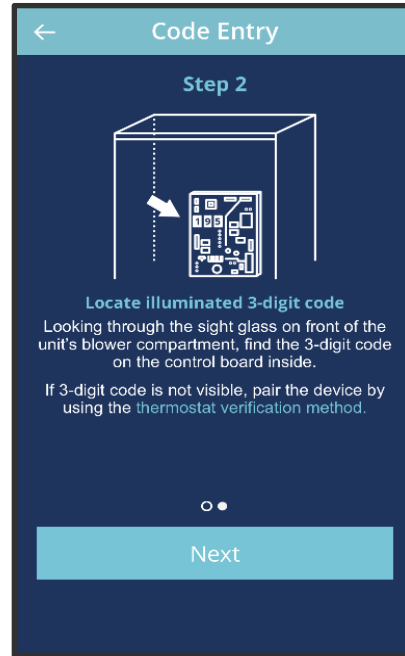
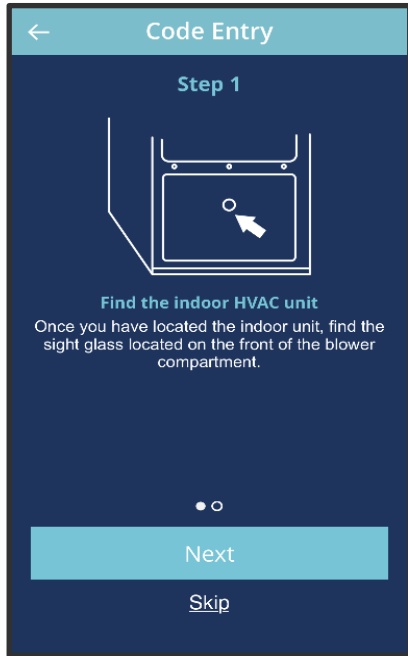

- If the code is visible, it can be entered in the Code Entry screen shown on the right.

Agenda

Goodman *GTST* Connected Thermostat

System Configurations

Installing Goodman *GTST* Connected Thermostat

Commissioning Goodman *GTST* Connected Thermostat
with Wi-Fi (*SkyportCare*-recommended)

Commissioning Goodman *GTST* Connected Thermostat
without Wi-Fi

SkyportHome App

Commissioning (with Wi-Fi)

- Download the *SkyportCare* app. from your respective app. store.
- You will need account to log in
 - This account will need to be tied to the dealer account registered with *SkyportCare*
 - If you do not have an account, click the create account link and follow the process on creating an account before getting started.
- Quality Install enables the technician to modify profile settings, run commissioning tests and verify charge through the app.

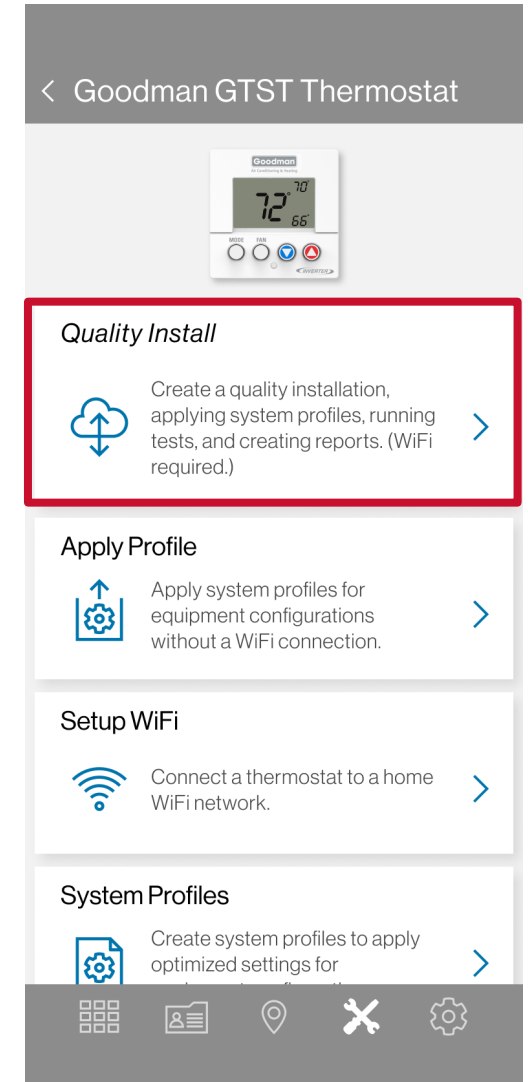
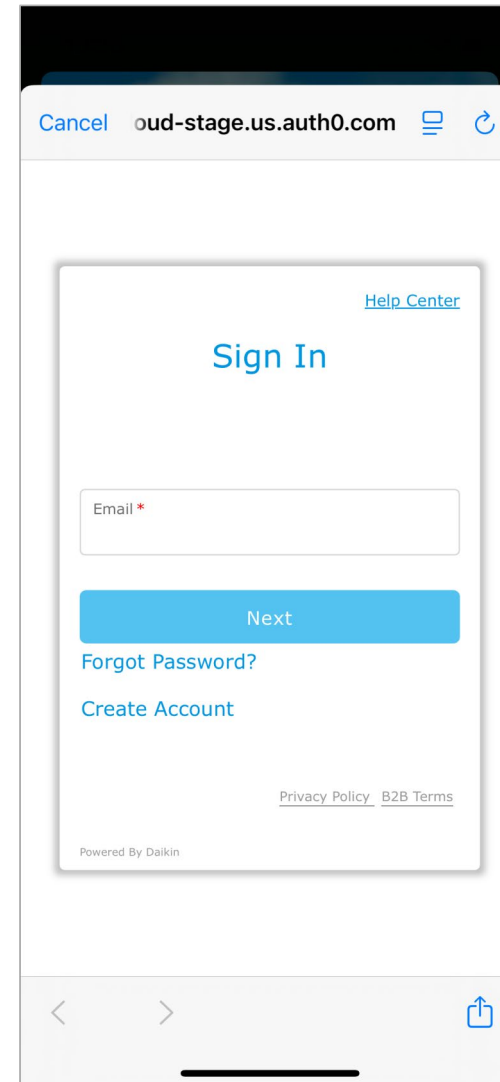
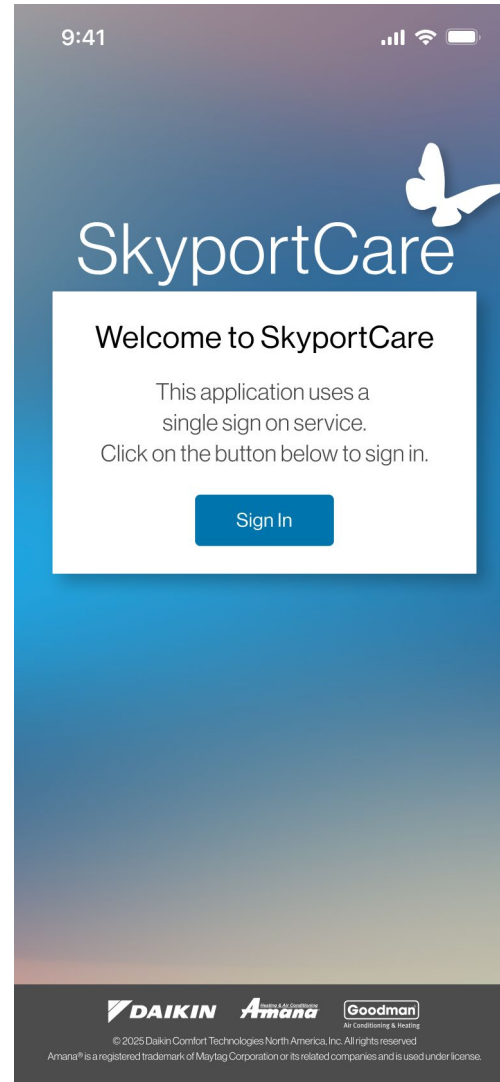

Create A Job Based On Location

- Every job needs the location details.
- Click on the “+” sign to add location details and continue.
 - The user can use their GPS location to automatically fill in the address.

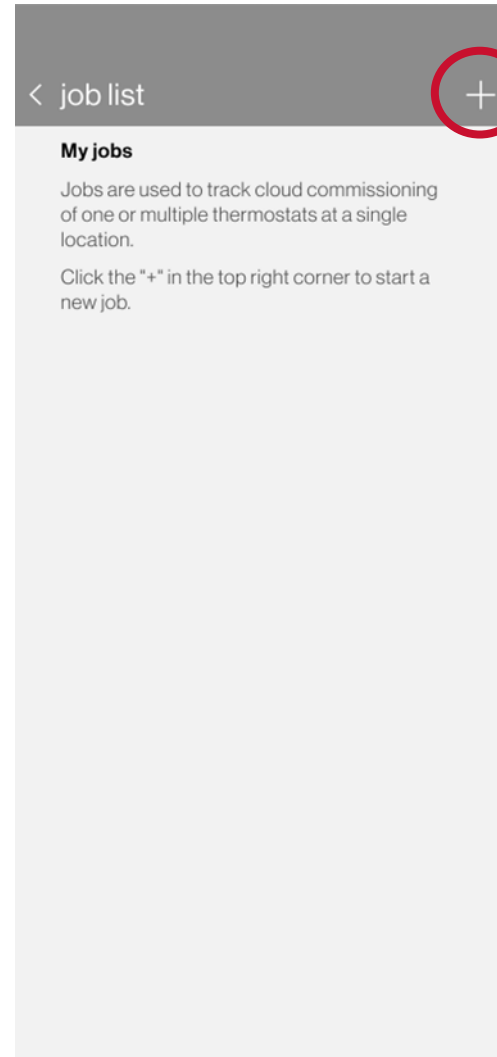

< job list

My jobs

Jobs are used to track cloud commissioning of one or multiple thermostats at a single location.

Click the "+" in the top right corner to start a new job.

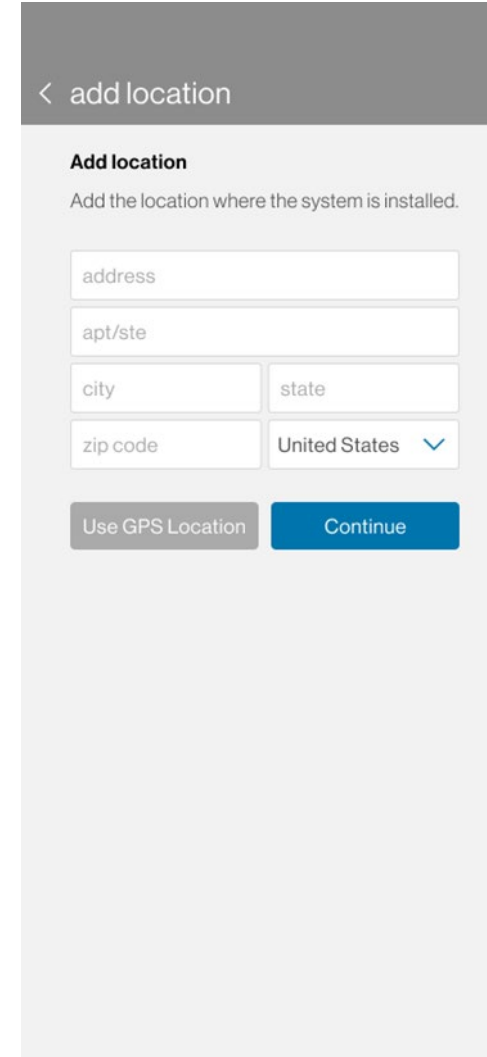

< add location

Add location

Add the location where the system is installed.

address

apt/ste

city state

zip code United States

Use GPS Location Continue

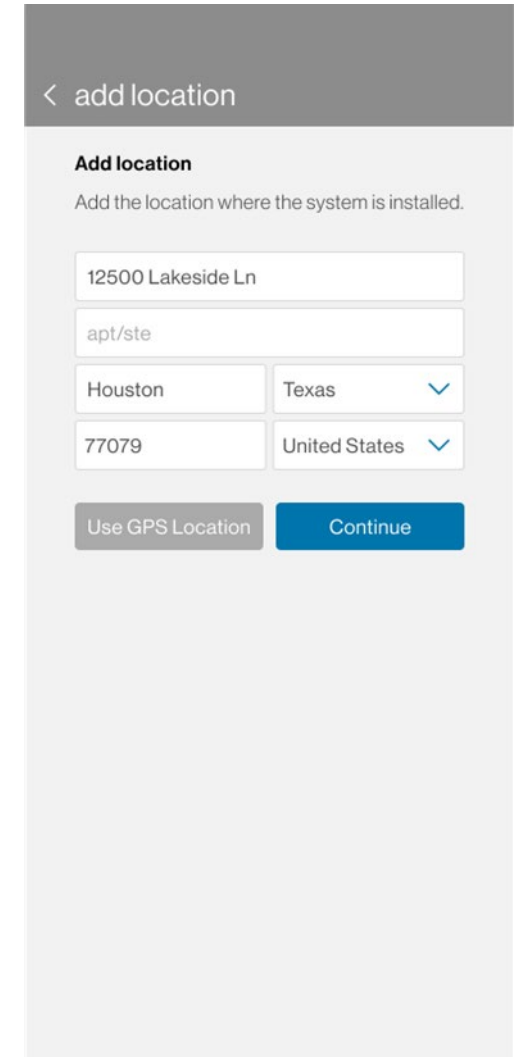

< add location

Add location

Add the location where the system is installed.

12500 Lakeside Ln

apt/ste

Houston Texas

77079 United States

Use GPS Location Continue

Add Thermostat To Job And Configure For Zoning If Needed

- Add thermostat by tapping on + in top right corner then scanning the 2D bar code or entering thermostat DKNS # manually.
 - The 2D bar code is found on the terminal subbase.
 - DKN # is found by navigating through the thermostat menus.
- Zone board configuration can be seen by sliding the toggle button to the right.
 - If a thermostat is connected to a zone board and not zone one, then equipment info will not be available.

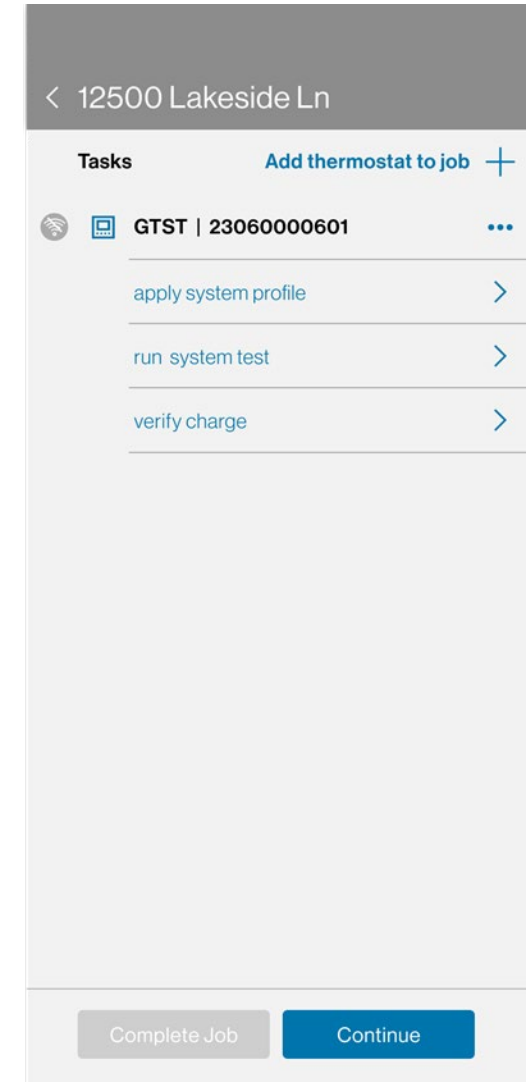
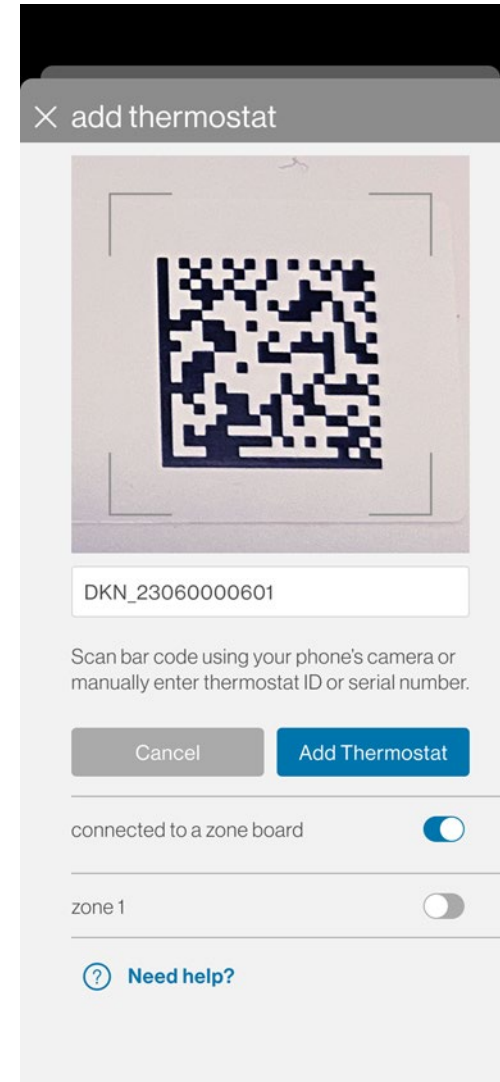
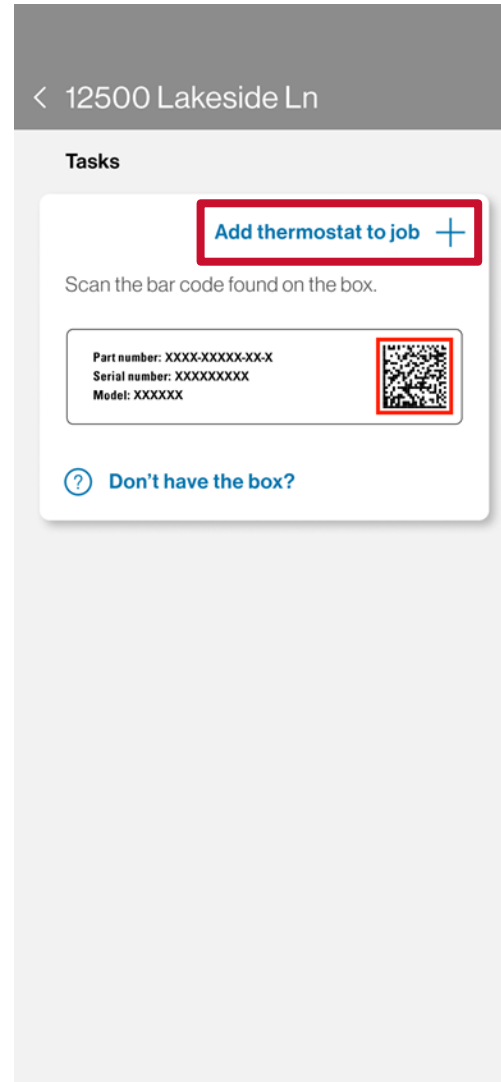

Connect To The Thermostat Using AP Mode

- On selection of any task, internet connection will need to be verified before the user can continue setup.
 - If the Wi-Fi icon is grey, the system is not connected to Wi-Fi.
 - If having connectivity issues through the app, turn off Wi-Fi assist (IOS) or Intelligent Wi-Fi (Android) on the mobile device.
- To connect to Wi-Fi, first click on “apply system profile”
- On the thermostat, press and hold the fan button for 5 seconds.
 - Release the fan button and press the down button to continue.
 - Approximately 10 seconds to enter AP mode.
 - AP mode must be active before tapping discover device.
 - When connecting to the thermostat's access point, the mobile device MUST be within two feet.

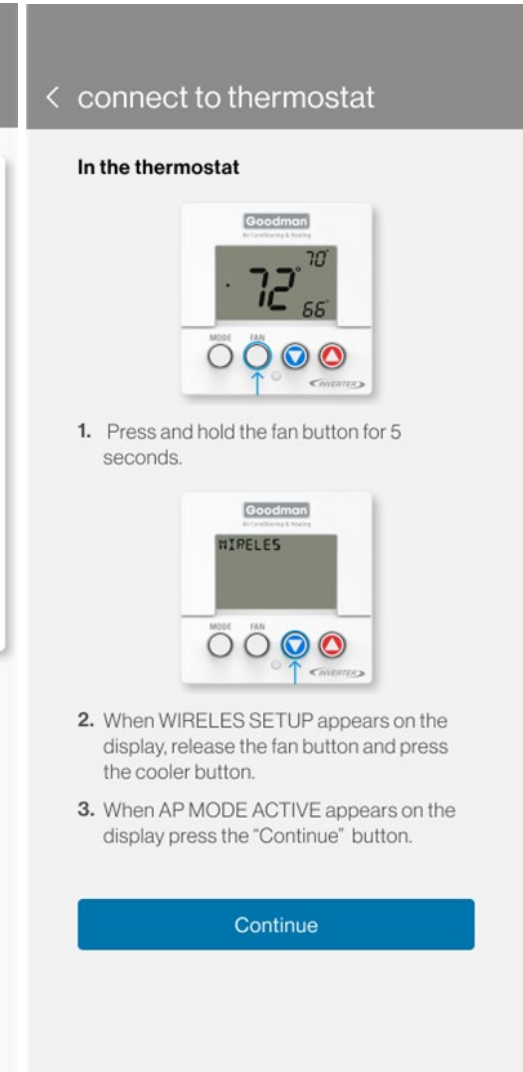
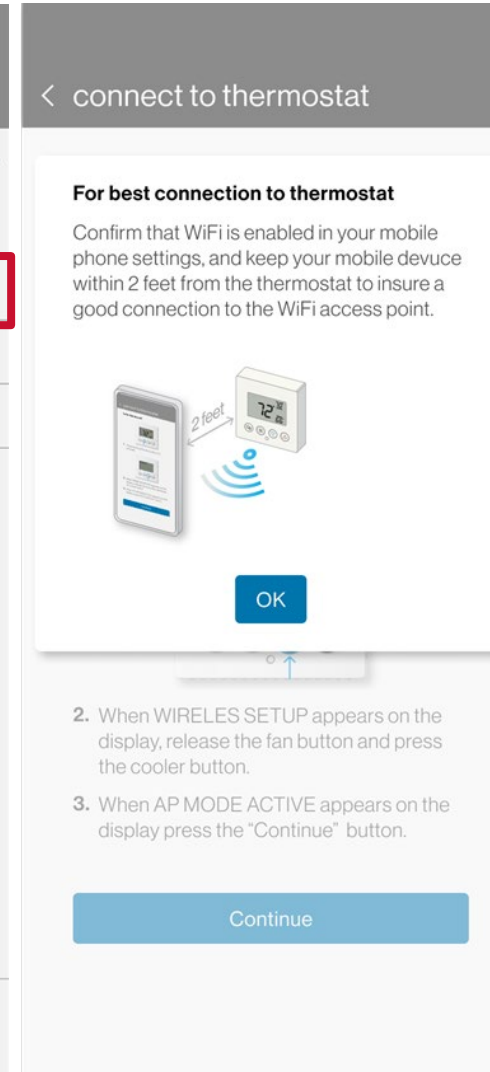
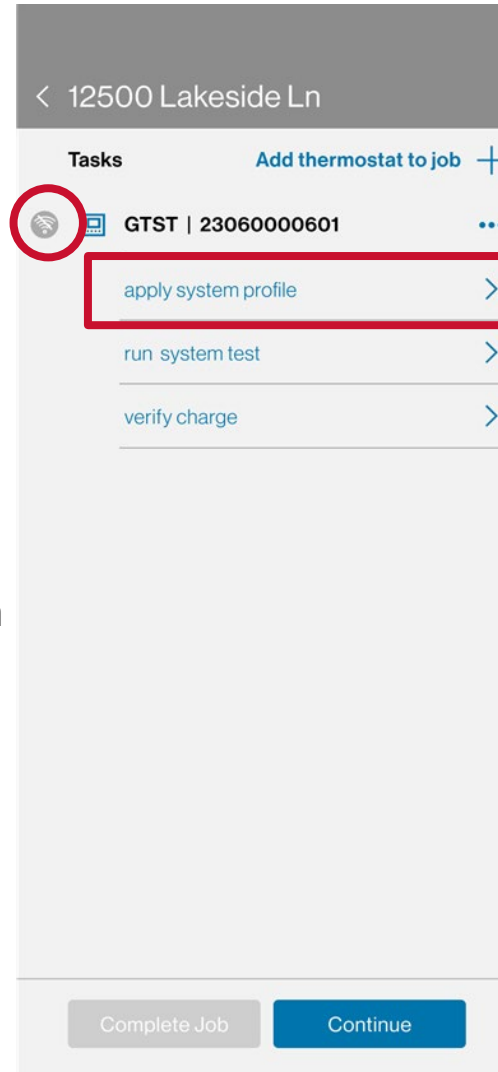

Connect To The Thermostat Using AP Mode

- The user will be prompted to open the mobile device's Wi-Fi settings and connect to the thermostat Wi-Fi.
 - Password: 123456789
- NOTE: The Skyport Care app. must remain open while accessing the mobile device's Wi-Fi settings.
- A message will appear at the top of the thermostat's UI informing the user that their mobile device is connected to the access point.

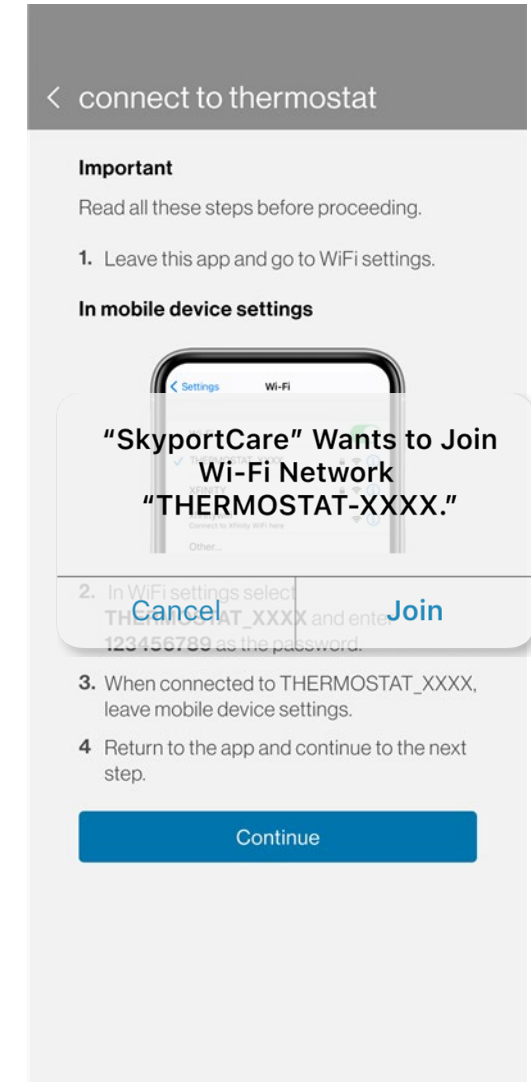
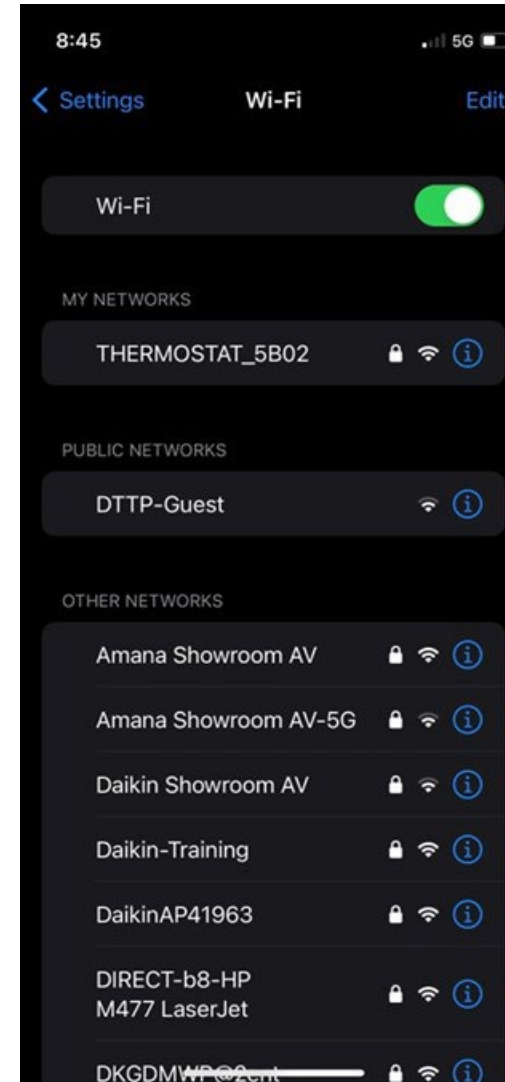
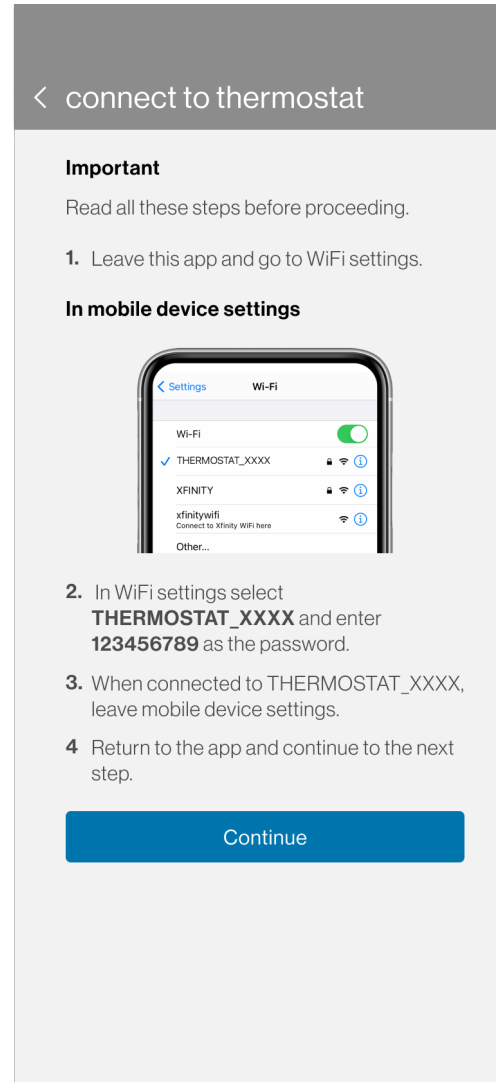

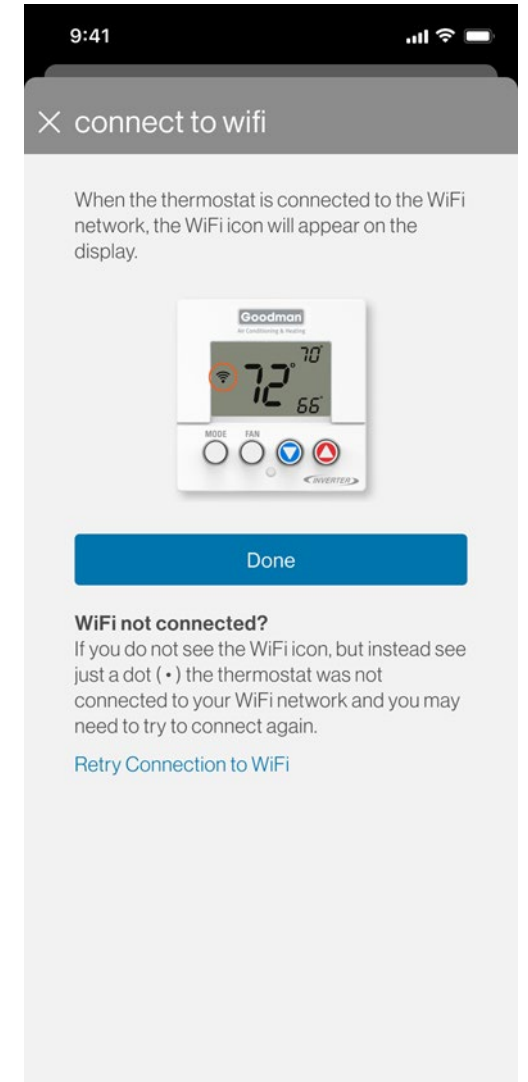
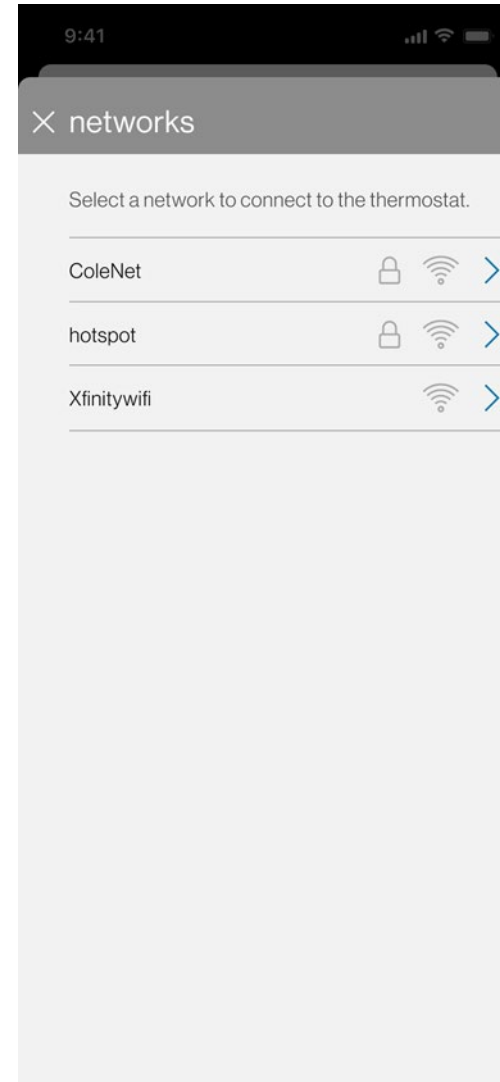

Connect To Home Wi-Fi

- Once connected to the thermostat, following the “Cloud Commissioning” process, the user can connect to a local Wi-Fi network and no longer need to maintain a 2ft. distance from the controller.
 - Must be password protected.



Apply System Profile

- A list of the connected equipment will be populated once connected to Wi-Fi.
 - Verify equipment, then continue to view thermostat profile options.
 - Once connected to Wi-Fi, the green  icon will be displayed. If access is expired, then the user will see the no access icon  .

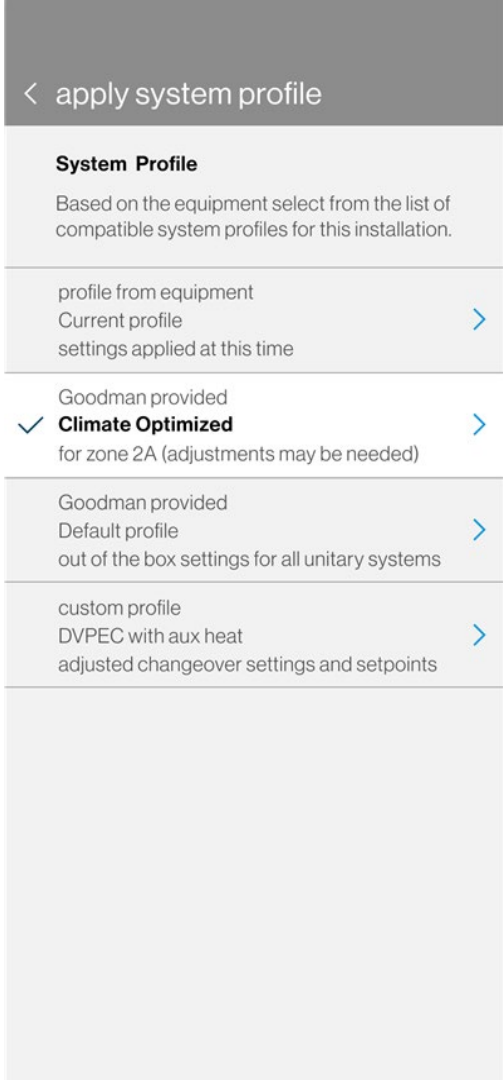
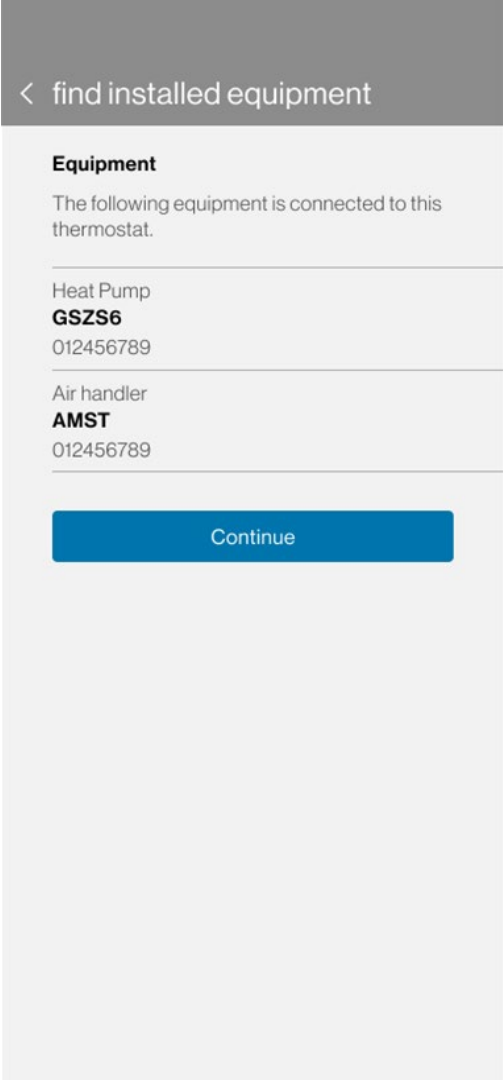
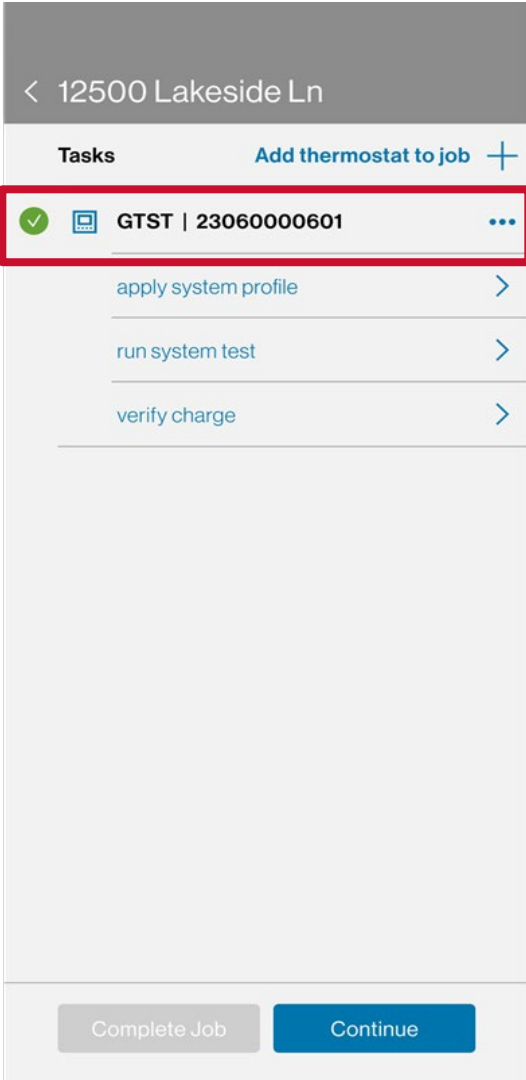

Apply System Profile (continued)

- You can select and or modify any profile to send to the thermostat.
 - Make edits as needed, then tap “Send to Thermostat”

NOTE: Modifying the profile does not affect the default profile

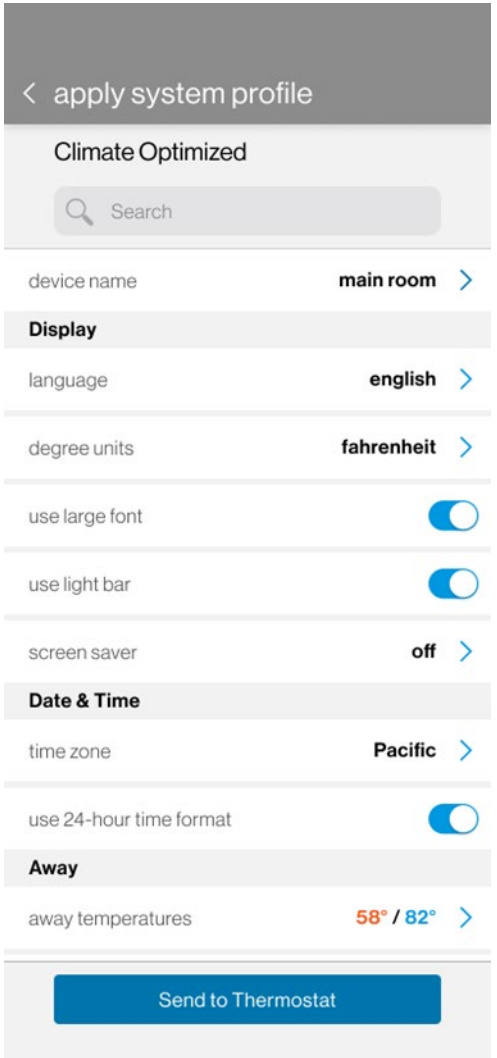
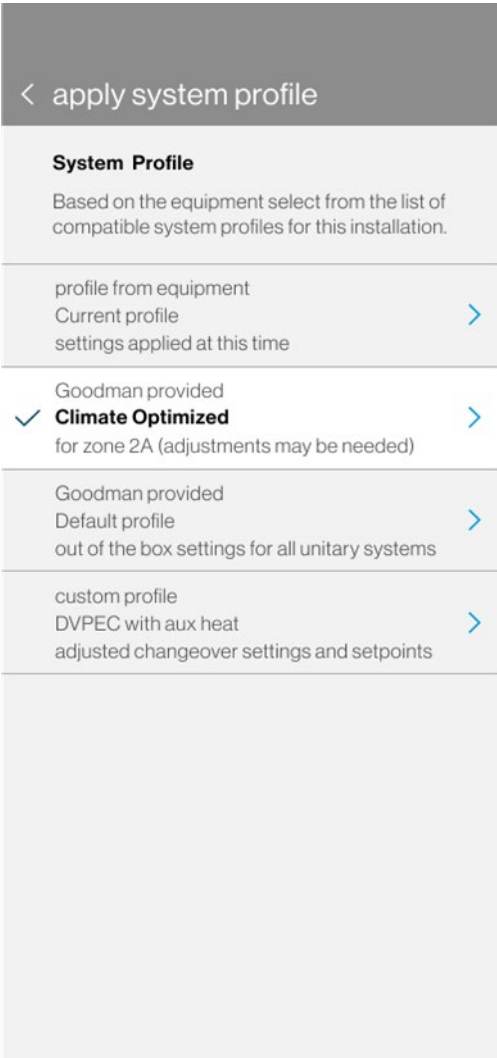

Run System Test

- Running system test will prompt the user to calculate the charge before running the test.
 - Measure total line set length, then select liquid and suction line diameter before calculating required trim charge.
 - Input the actual charge weighed in.

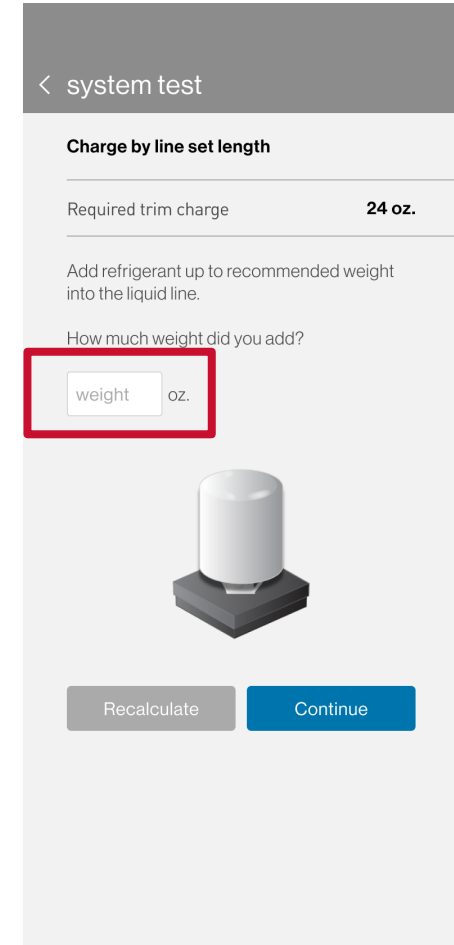
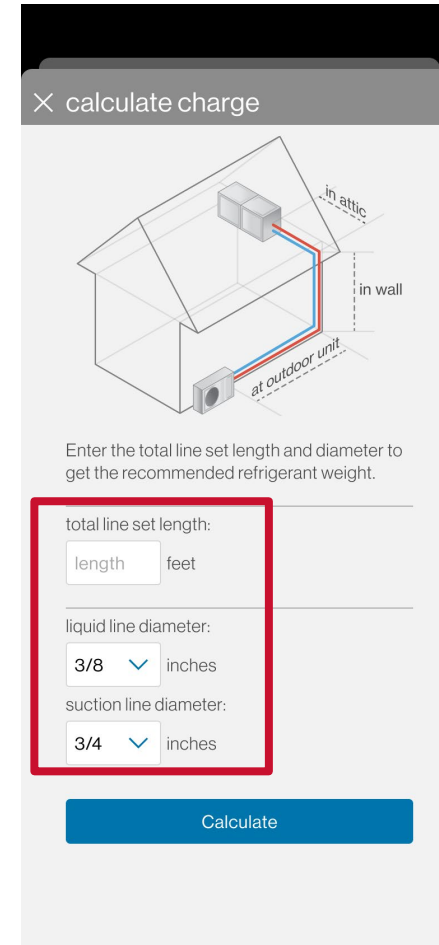
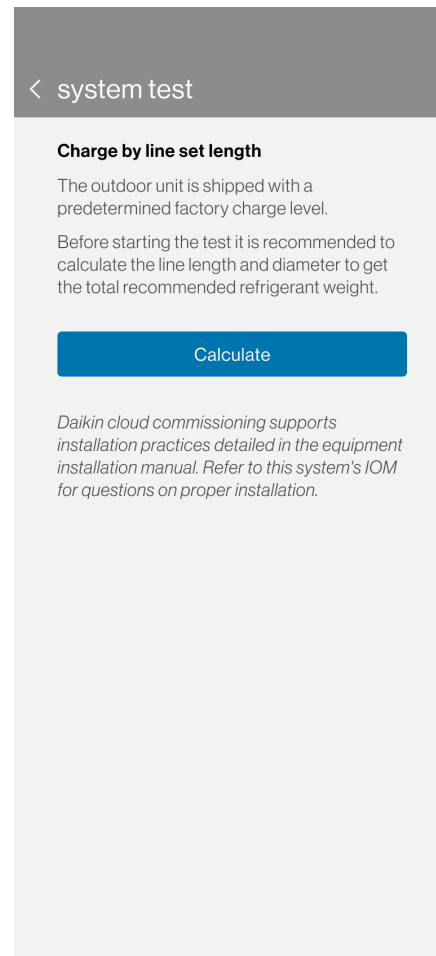
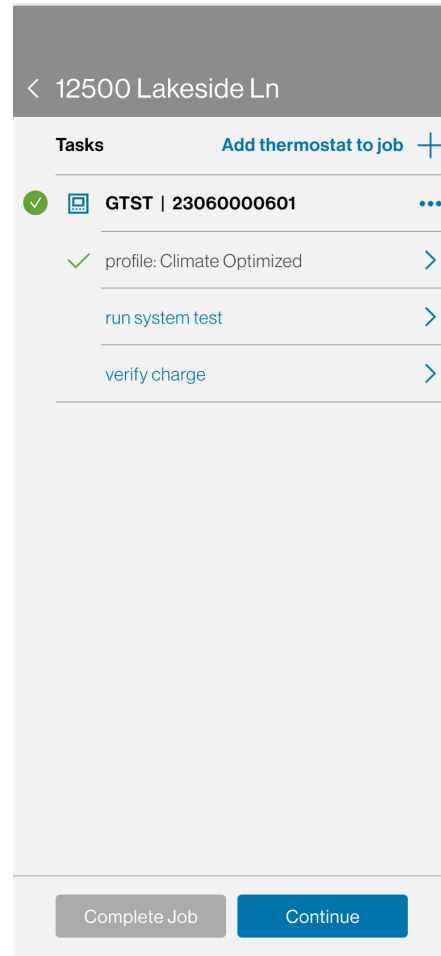

Run System Test

- Verify service valves are open.
 - Tap “Run Test.”
 - Users can leave the screen while the test is running and return as needed.
 - System test is required for inverter systems.
 - If the test has not been completed an error code "11" will be generated.
 - Error code "11" will clear once the test is complete.

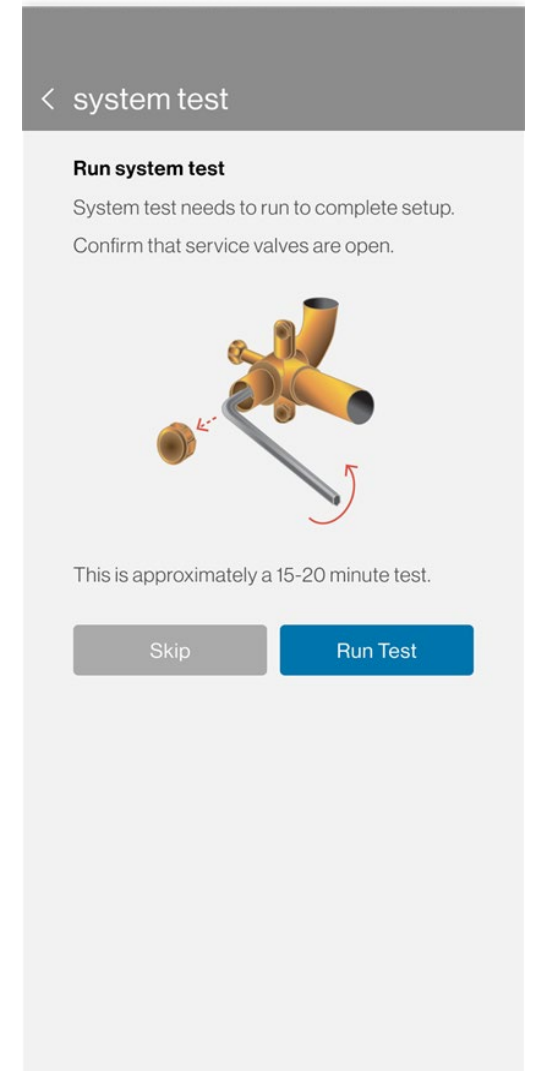

Run System Charge Verification

- Recommended charge to be added to meet required charge displayed.
- Measure subcooling and verify proper specifications are met utilizing the charging chart in the IOM.
- Once system stabilizes and is running at full speed, the calculated subcool will be displayed.
 - Allow up to 5 min delay between gauge reading and app. verification.
 - Stopping the verification will generate a report.

< 12500 Lakeside Ln

Tasks [Add thermostat to job](#) +

- ✓ **GTST | 23060000601** ...
- ✓ profile: Climate Optimized >
- ✓ system test completed >
- [verify charge](#) >

Complete Job Continue

< verify charge

Charge verification

Required trim charge	24 oz.
Added	10 oz.
Additional charge needed	14 oz.

It is recommended to add 4 oz. refrigerant each time and let the system stabilize.

Charge Verification Mode runs the system at 50% cooling for verifying and adjusting the refrigerant charge of the system. It will run the System Test first if needed, and will turn off automatically after 2 hours if not stopped manually before then.

Skip Verify

While the system is in charge mode, the thermostat will display "Off." Do not adjust the thermostat until charge has been verified and you have stopped charge mode.

< verify charge

Charge verification

Charge to recommended refrigerant weight:

14 oz.

? Measure subcooling to verify proper charge.

90 °F outdoor temp

100% compressor speed

9.9 °F

calculated subcool system stable

*charging time may vary

Stop Verification Continue

Complete Setup

- After all steps are complete, the user will be able to share a commissioning report before completing the job.

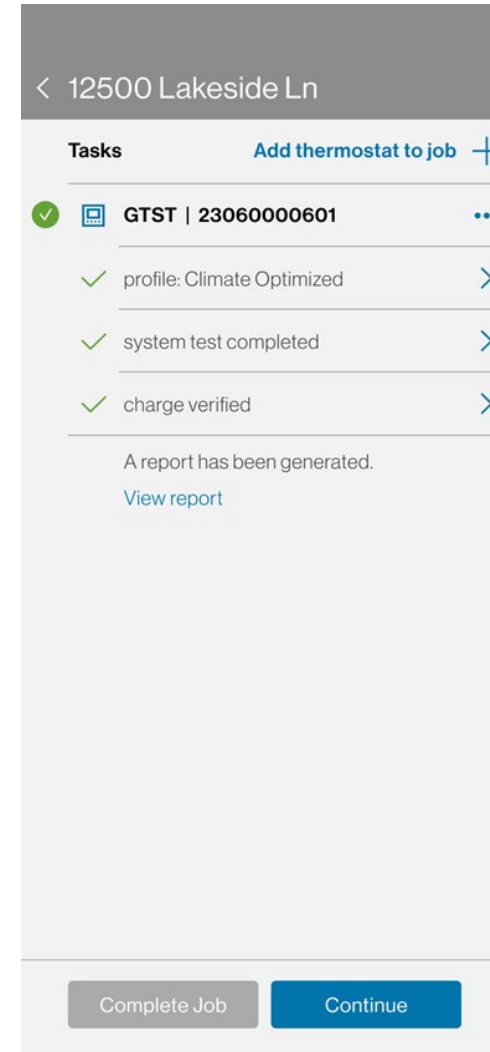

Agenda

Goodman *GTST* Connected Thermostat

System Configurations

Installing Goodman *GTST* Connected Thermostat

Commissioning Goodman *GTST* Connected Thermostat
with Wi-Fi (*SkyportCare*-recommended)

**Commissioning Goodman *GTST* Connected Thermostat
without Wi-Fi**

SkyportHome App

Commissioning (without Wi-Fi)

- Download the Skyport Care app from your respective app store.
- You will need an account to log in
 - This account will need to be tied to the dealer account registered with *SkyportCare*
 - If you do not have an account, click the create account link and follow the process on creating an account before getting started.
- Apply Profile enables the technician to modify profile settings and send them to the thermostat through the app.

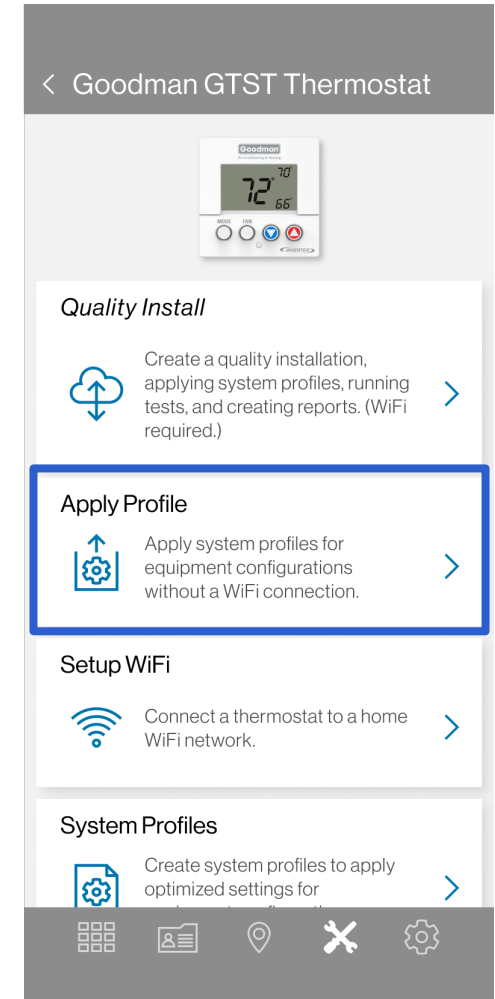
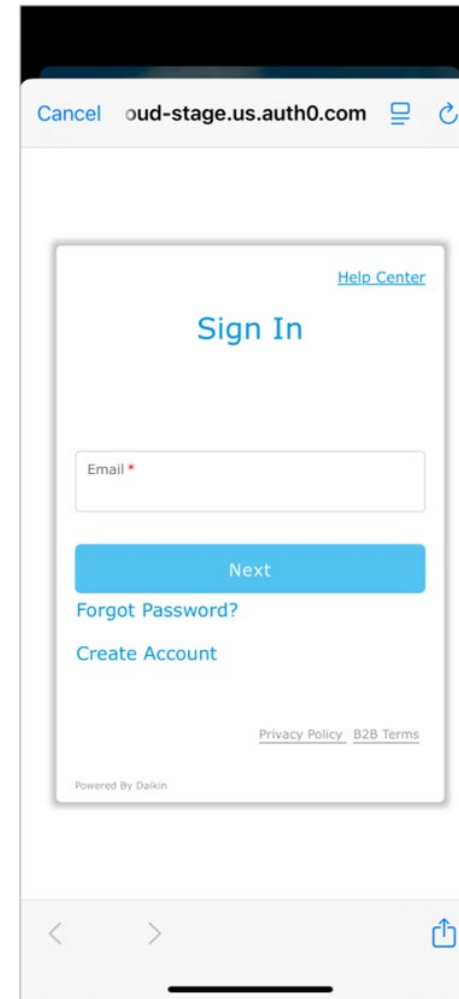
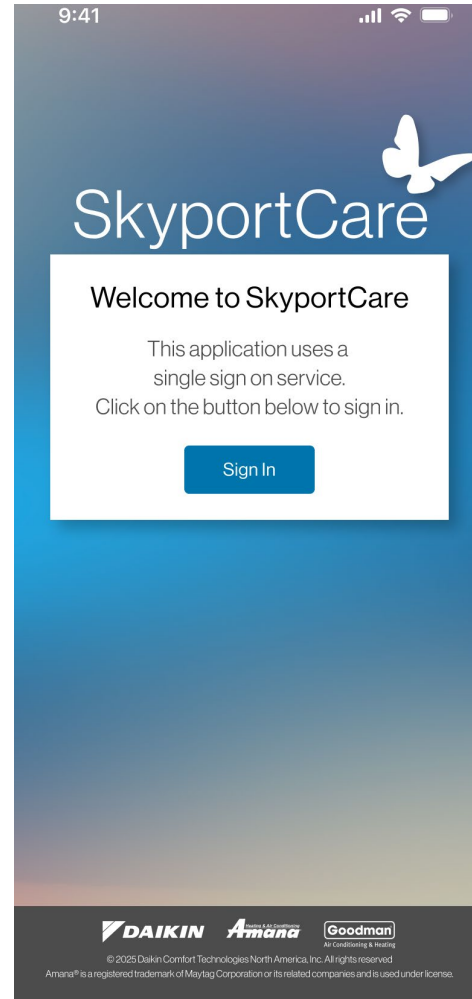

Must have Wi-Fi enabled on your mobile device without a network connected

Connect To The Thermostat Using AP Mode

- On the thermostat, press and hold the fan button for 5 seconds.
 - Release the fan button and press the down button to continue.
 - Approximately 10 seconds to enter AP mode.
 - AP mode must be active before tapping discover device.
 - When connecting to the thermostat's access point, the mobile device **MUST** be within two feet.

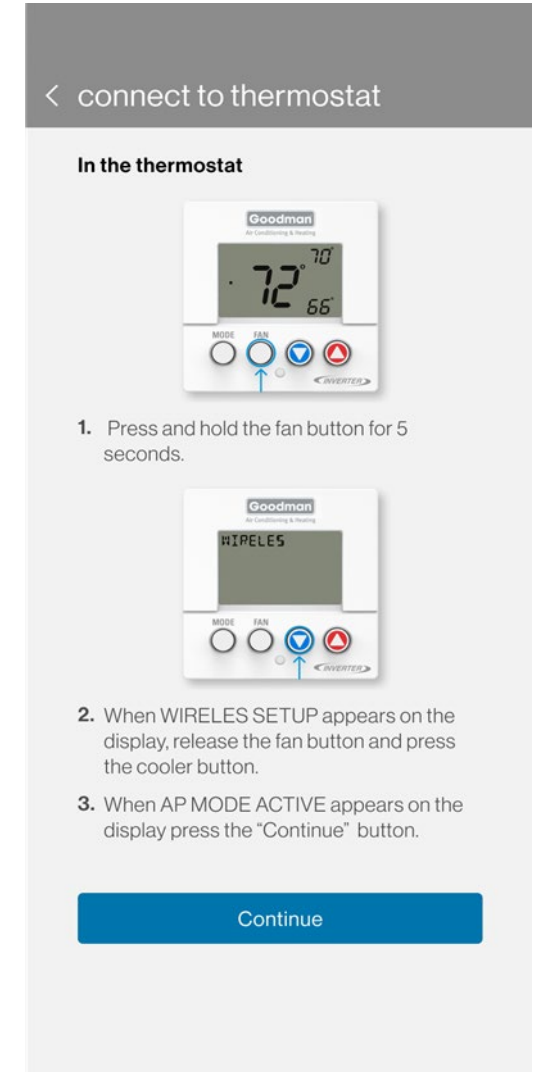
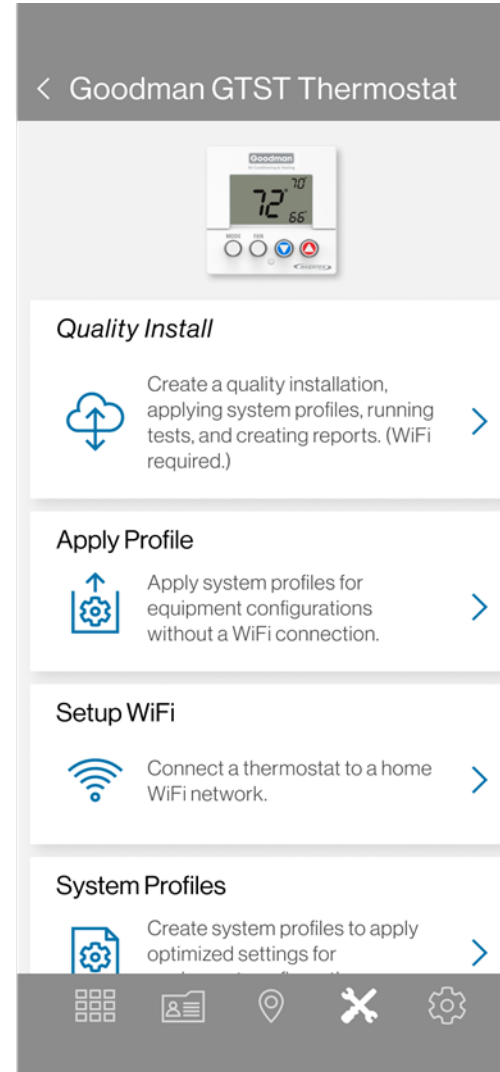

Connect To The Thermostat Using AP Mode

- The user will be prompted to open the mobile device's Wi-Fi settings and connect to the thermostat Wi-Fi.

- Password: 123456789
- If having connectivity issues through the app, turn off Wi-Fi assist (IOS) or Intelligent Wi-Fi (Android) on the mobile device.

NOTE: The *SkyportCare* app. must remain open while accessing the mobile device's Wi-Fi settings.

- A message will appear at the top of the thermostat's UI informing the user that their mobile device is connected to the access point.

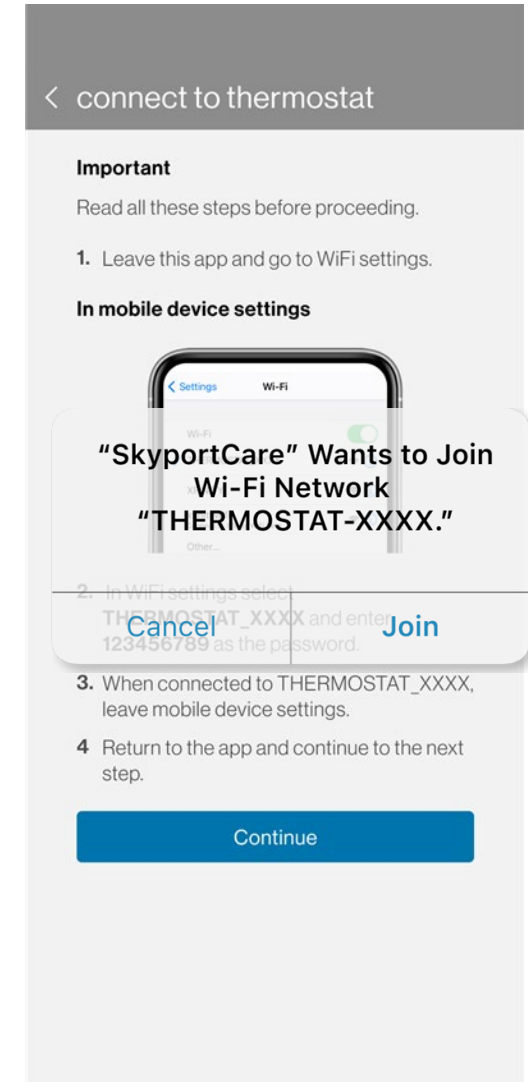
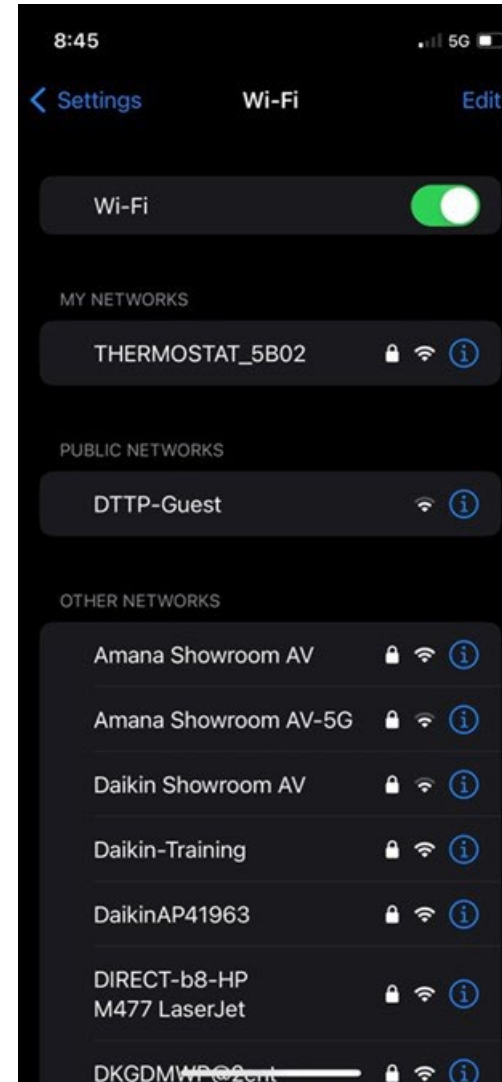
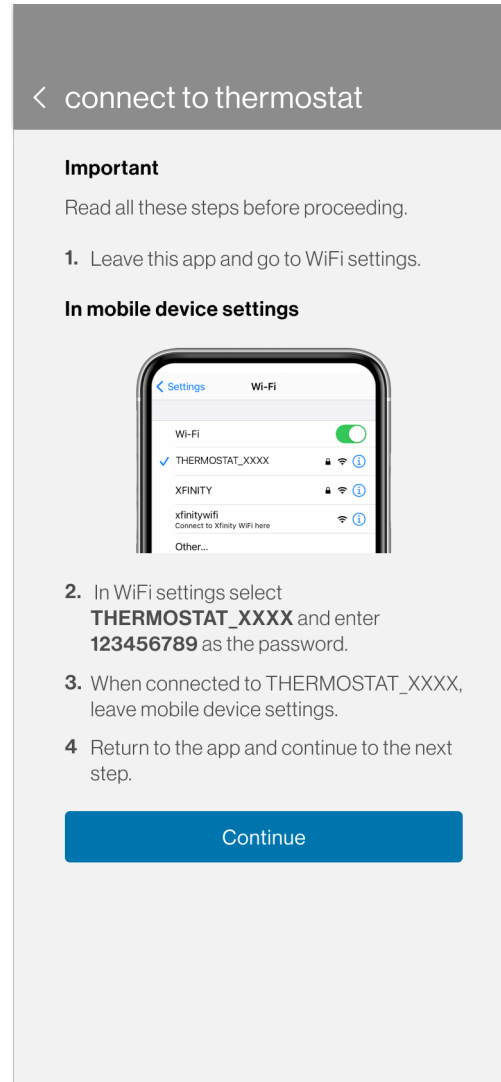

Apply System Profile

- A list of the connected equipment will be populated once equipment settings are detected (may take several minutes).
 - Verify equipment, then continue to view thermostat profile options.

< apply system profile

System Profile
Based on the equipment select from the list of compatible system profiles for this installation.

profile from equipment
Current profile settings applied at this time >

Goodman provided
✓ **Climate Optimized** >
for zone 2A (adjustments may be needed)

Goodman provided
Default profile >
out of the box settings for all unitary systems

custom profile
DVPEC with aux heat >
adjusted changeover settings and setpoints

< find installed equipment

Equipment
The following equipment is connected to this thermostat.

Heat Pump
GSZS6
012456789

Air handler
AMST
012456789

Continue



Apply System Profile (continued)

- You can select and or modify any profile to send to the thermostat.
 - Make edits as needed, then tap “Send to Thermostat”
 - Without being connected to a network, the user **MUST** be within two feet of the thermostat.

NOTE: Modifying the profile does not affect the saved profile

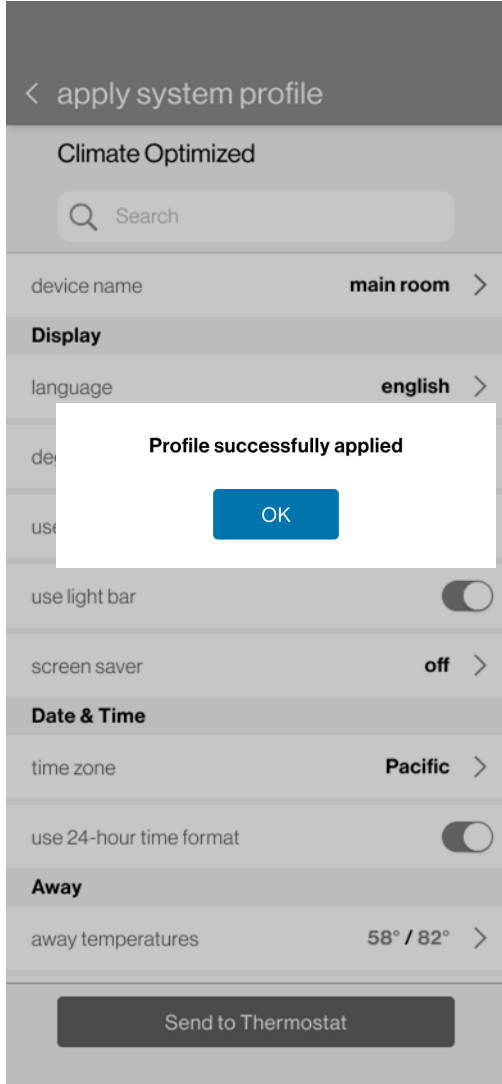
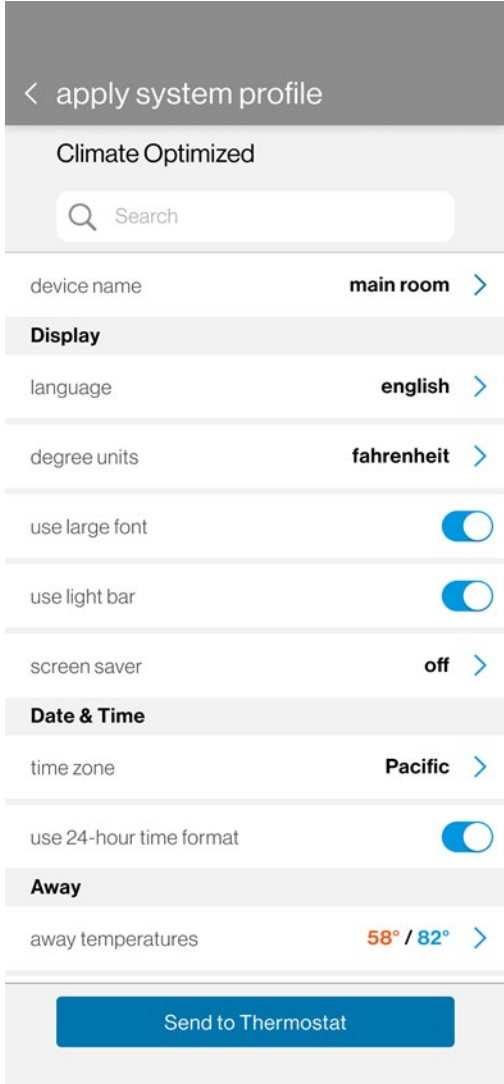
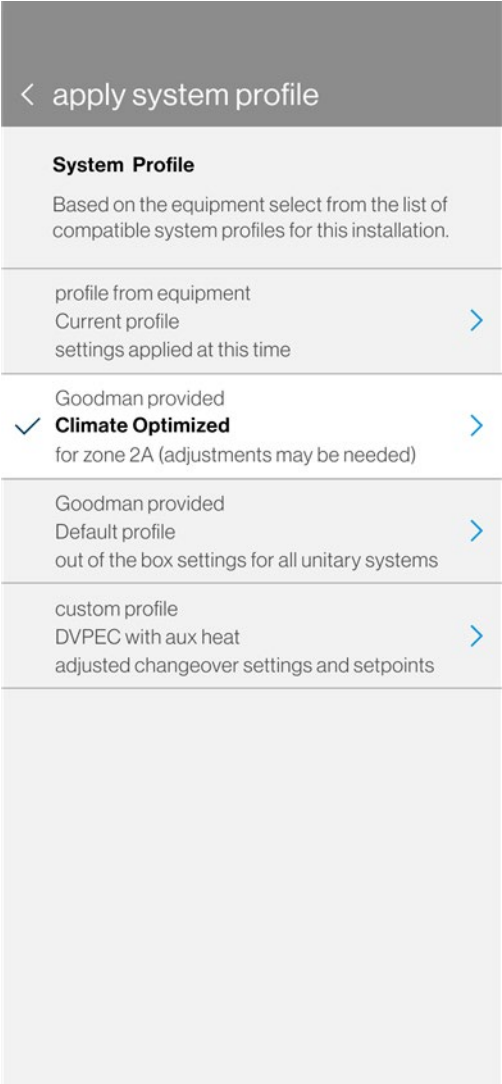

Running System Test (without Wi-Fi)

- On the thermostat, press and hold MODE/FAN buttons at the same time for 5 seconds to enter setup options.
- Navigate to step 20 by pressing the MODE button.
- Hold the FAN button for approximately two seconds will turn system test on.
 - The system test cannot be stopped once started. This test should take about 15 minutes to complete.
- The display will cycle through the message, “System Test Running” while testing.
- When the system test is complete, press the MODE button to return to the main menu.

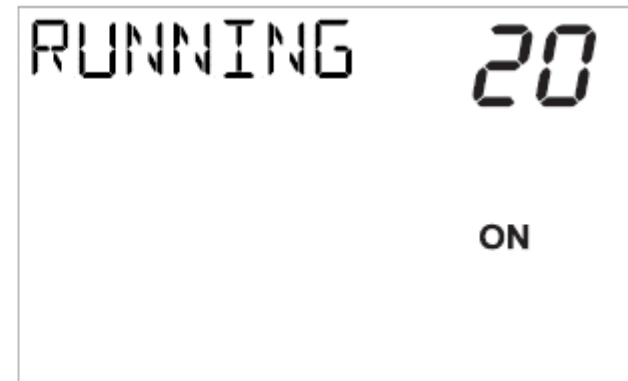
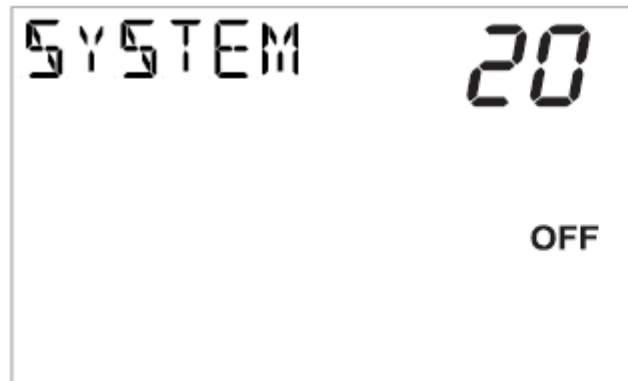
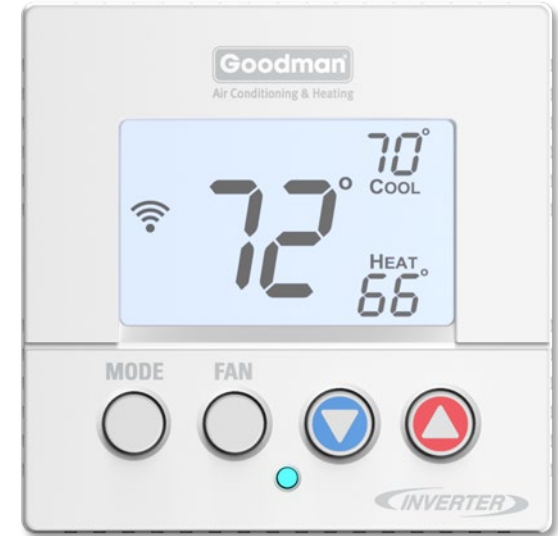

Charge Verification (without Wi-Fi)

- On the thermostat, make sure system mode is in Cooling, and drop the set point to the lowest cooling mode temperature.
 - Approximately 50°F to run maximum cooling.
- System must reach maximum speed to charge the system and measure subcool using gauges and temperature clamp.
- Weigh-in any additional charge needed to meet requirements on corresponding charging chart.

NOTE: Charge verification can also be initiated by navigating through the screens on seven-segment display of the ODU. This process is found in the ODU IOM.

SCREEN 4 (SETTING MODE 2)

Setting No.	Contents	Setting	Installer/Service Man Notes
1	Maximum Defrost Interval ^{**}	0: 30min. 1: 60min. 2: 90min. 3: 120min.	
2	Set Maximum Current	N/A	Future Use
3	N/A	N/A	
4	System Verification Test (System test)	0:ON 1:OFF	
7	Force Defrost Cycle ^{**}	0:ON 1:OFF	
9	Charge Mode	0:ON 1:OFF	
10	Maximum Compressor RPS for Cooling	0: -10.0 RPS 1: -9.5 RPS 2: -9.0 RPS 3: -8.5 RPS 4: -8.0 RPS 5: -7.5 RPS 6: -7.0 RPS 7: -6.5 RPS 8: -6.0 RPS 9: -5.5 RPS 10: -5.0 RPS 11: -4.5 RPS 12: -4.0 RPS 13: -3.5 RPS 14: -3.0 RPS 15: -2.5 RPS 16: -2.0 RPS 17: -1.5 RPS 18: -1.0 RPS 19: -0.5 RPS 20: 0.0 RPS 21: 0.5 RPS 22: 1.0 RPS 23: 1.5 RPS 24: 2.0 RPS 25: 2.5 RPS 26: 3.0 RPS 27: 3.5 RPS 28: 4.0 RPS 29: 4.5 RPS 30: 5.0 RPS 31: 5.5 RPS 32: 6.0 RPS 33: 6.5 RPS 34: 7.0 RPS 35: 7.5 RPS 36: 8.0 RPS 37: 8.5 RPS 38: 9.0 RPS 39: 9.5 RPS 40: 10.0 RPS	Can adjust comp RPS in each 0.5 RPS.
11	Maximum Compressor RPS for Heating ^{**}		Can adjust comp RPS in each 0.5 RPS.
12	COOLING BOOST MODE Selection	0:ON 1:OFF	
13	COOLING BOOST MODE Temperature	0:105F, 1:100F , 2:95F, 3:90F, 4:85F, 5:80F, 6:75F, 7:70F, 8:Always ON	
15	N/A	N/A	
16	Noise down level	0:LEVEL1 1:LEVEL2 2:LEVEL3	
17	N/A	N/A	
18	N/A	N/A	
19	Capacity priority	0:OFF 1:ON	
22	DEFROST HEAT ^{**}	0:Always ON, 1:30F, 2:35F, 3:40F, 4:45F, 5:50F, 6:55F, 7:60F, 8:65F, 9:OFF	
28	HEATING BOOST MODE ^{**}	0:OFF 1:ON	

Agenda

Goodman *GTST* Connected Thermostat

System Configurations

Installing Goodman *GTST* Connected Thermostat

Commissioning Goodman *GTST* Connected Thermostat
with Wi-Fi (*SkyportCare*-recommended)

Commissioning Goodman *GTST* Connected Thermostat
without Wi-Fi

SkyportHome App

Account Set-up

- Setting up an account is a five-step process.
 - Downloading the application from your IOS or Android application store.
 - Creating the account.
 - Confirming your account.
 - Adding the thermostats' location.
 - Connecting the app to the thermostat.

Note: A mobile device, the *GTST Connected Thermostat* connected to Wi-Fi that is wired to a communicating system and a valid email address is needed to create a mobile account.

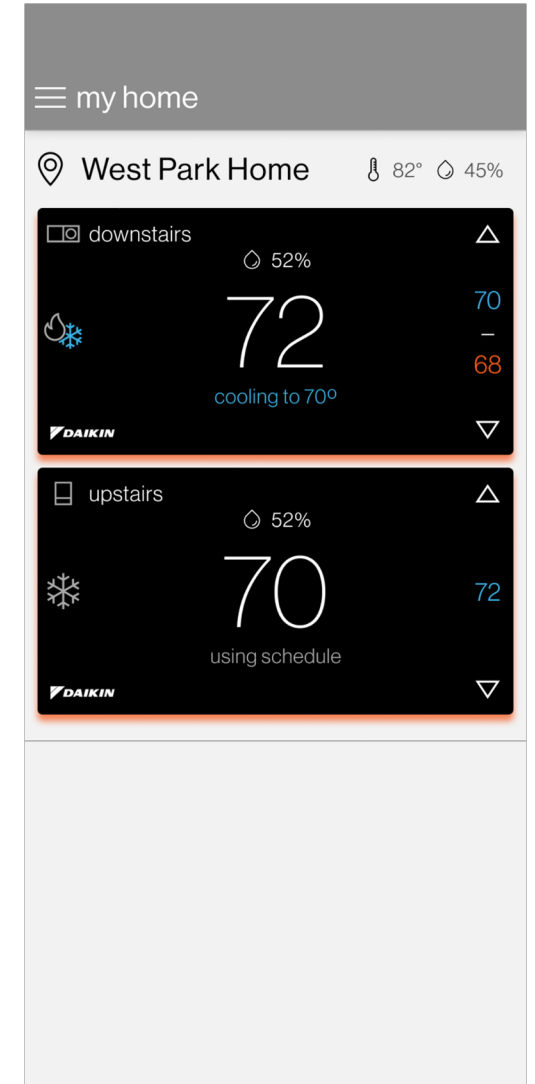
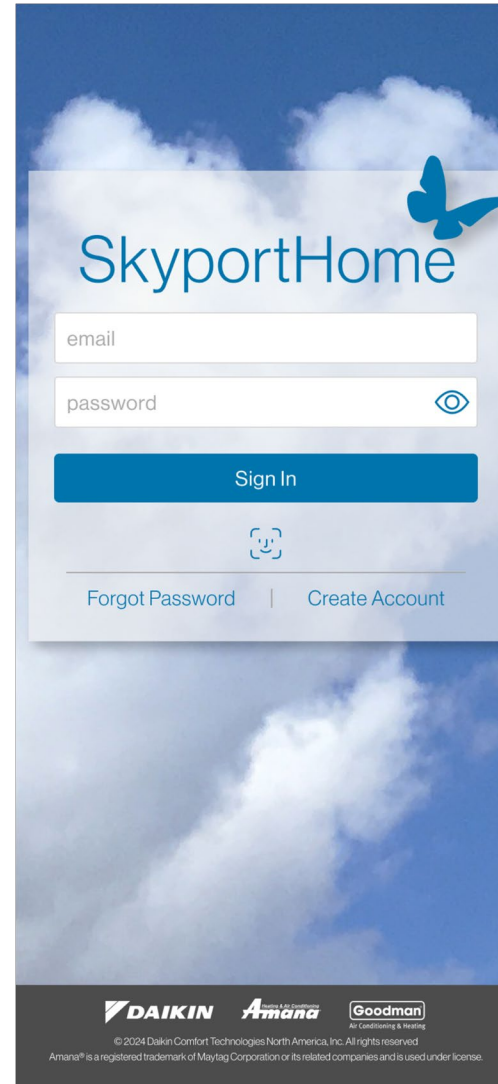

Create The Account

- Tapping **create account** at will start the process.
- **Before agreeing**, read the terms and service, privacy statement, and other notices.
- Fill in your name, valid email address, and password.

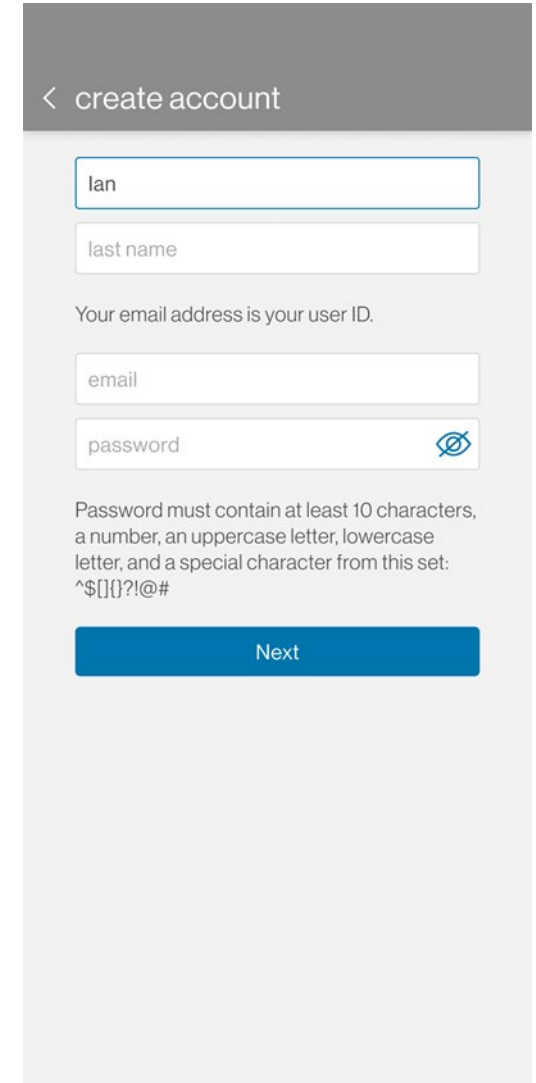
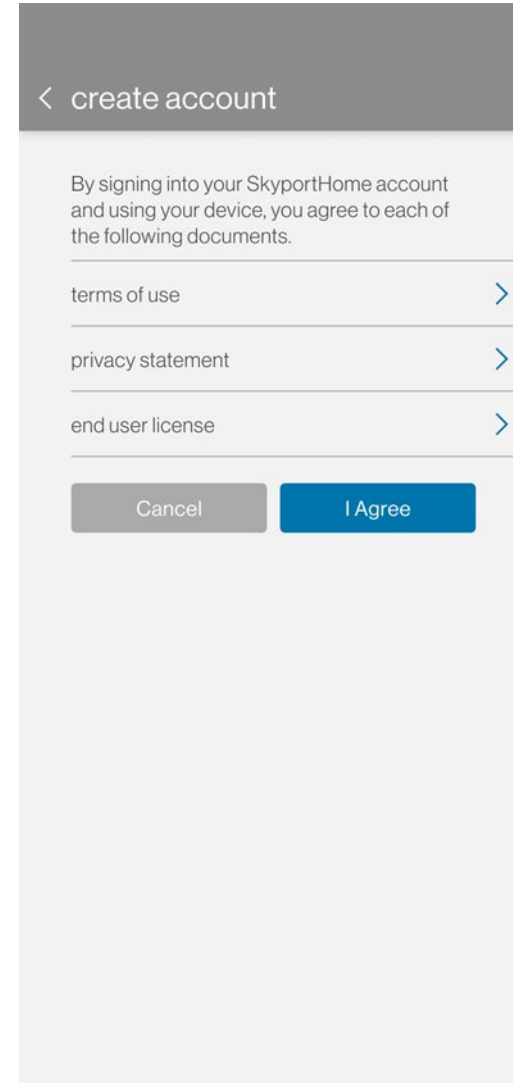
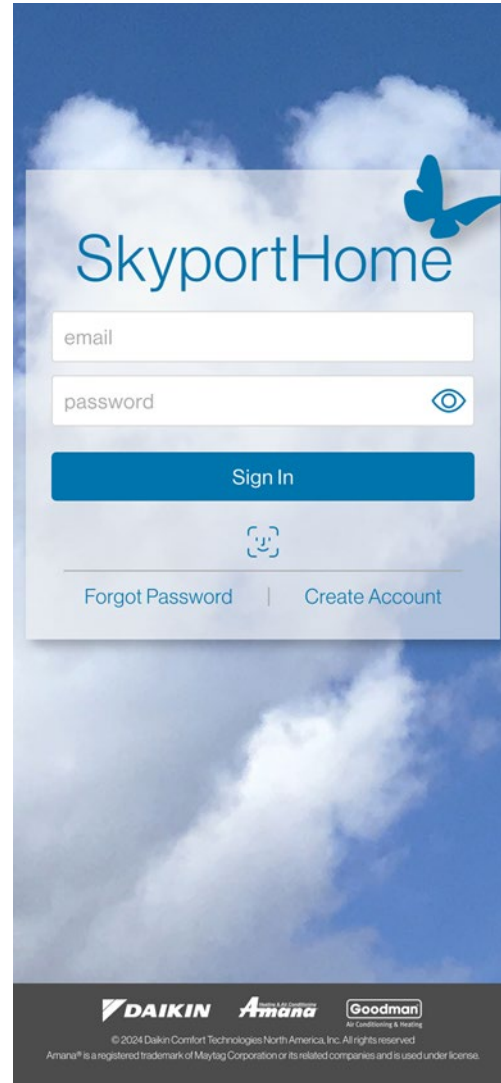

Confirming The Account

- You will be prompted to access the **email address** you provided when creating the account.
- A welcome email will appear in your inbox providing a **six-digit** code.
- Entering the six-digit code on your phone app. will allow you to continue.

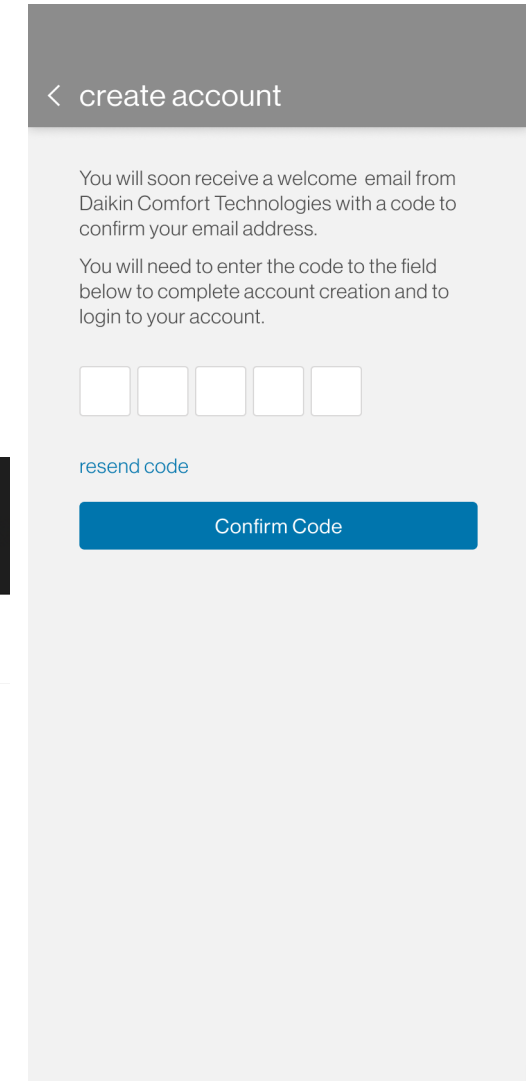
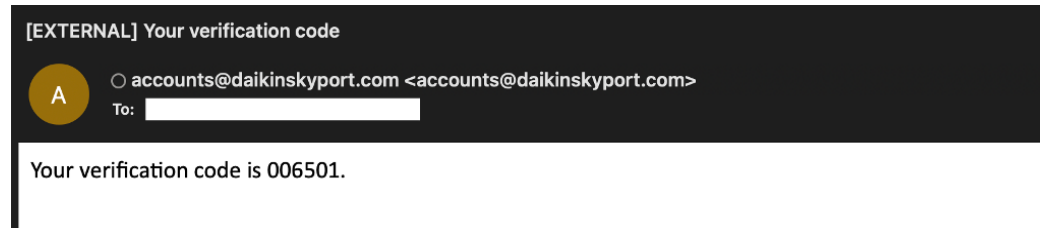

Adding The Thermostat's Location

- Tap the login button and enter the email and password associated to your mobile account and.
 - If you have forgotten your password, tap the forgot password link to recover information via email.
- Type the address of where the thermostat is located to gather accurate information.
- Click Save This Location

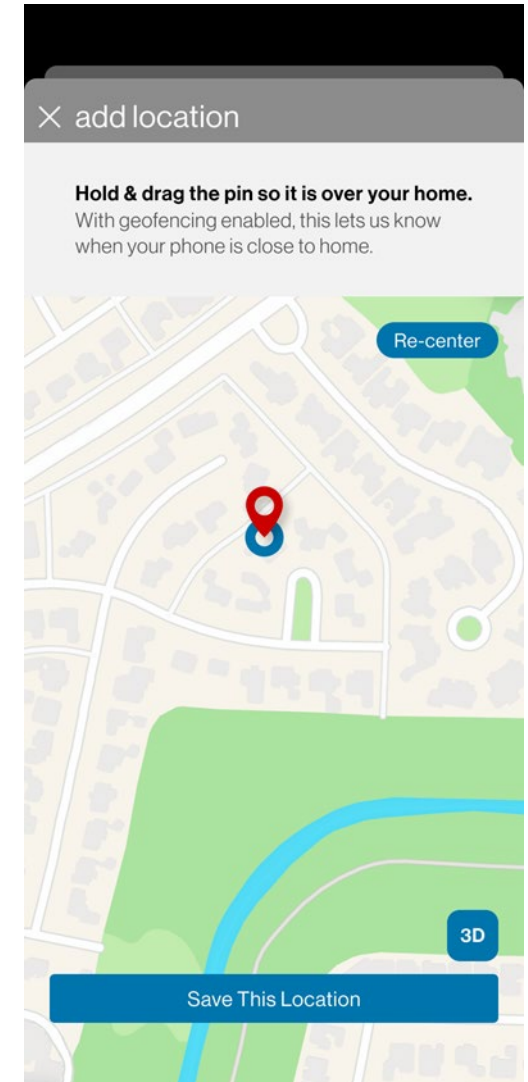
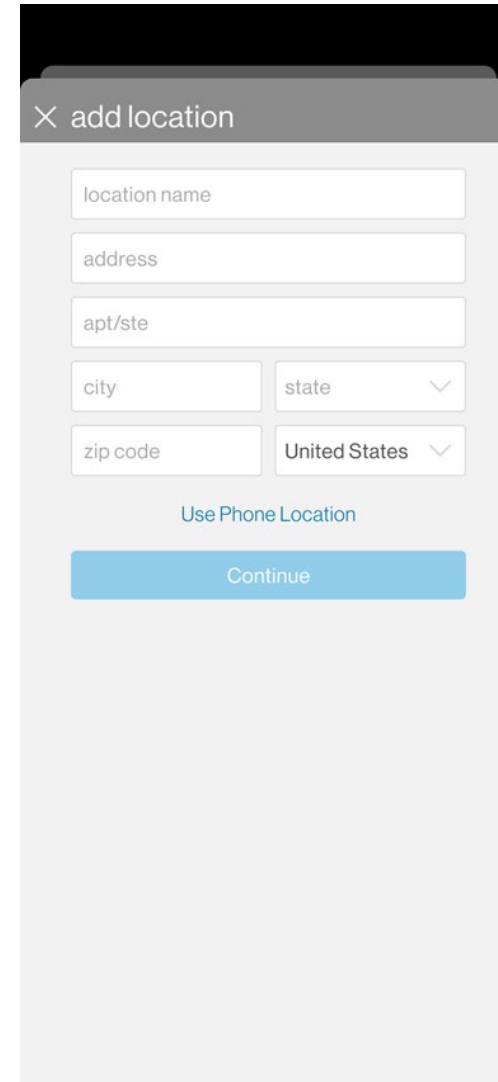
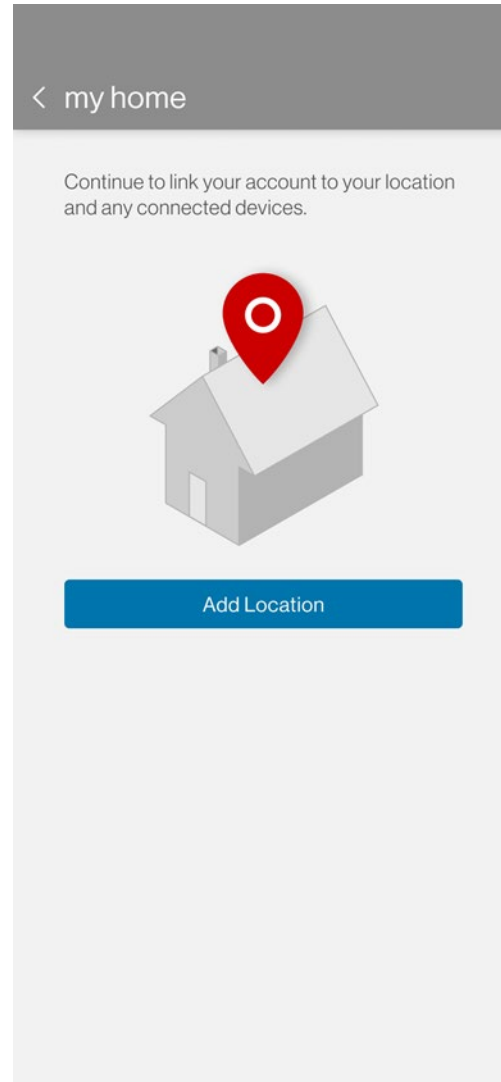

Connecting The App. To The Thermostat

- Tap the added location and select “add thermostat”.
- Once the thermostat has been selected in the app., press and hold the fan button on the thermostat until the words “wireless setup” appears.
 - Select next on the mobile app. after “wireless setup” appears.

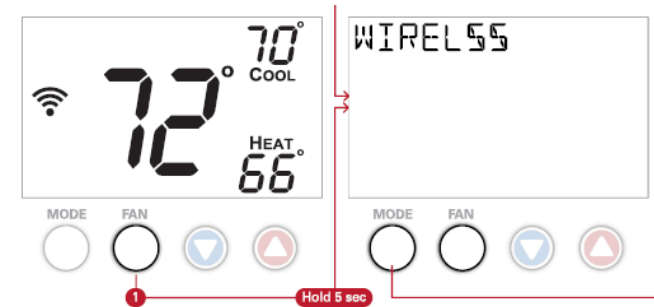
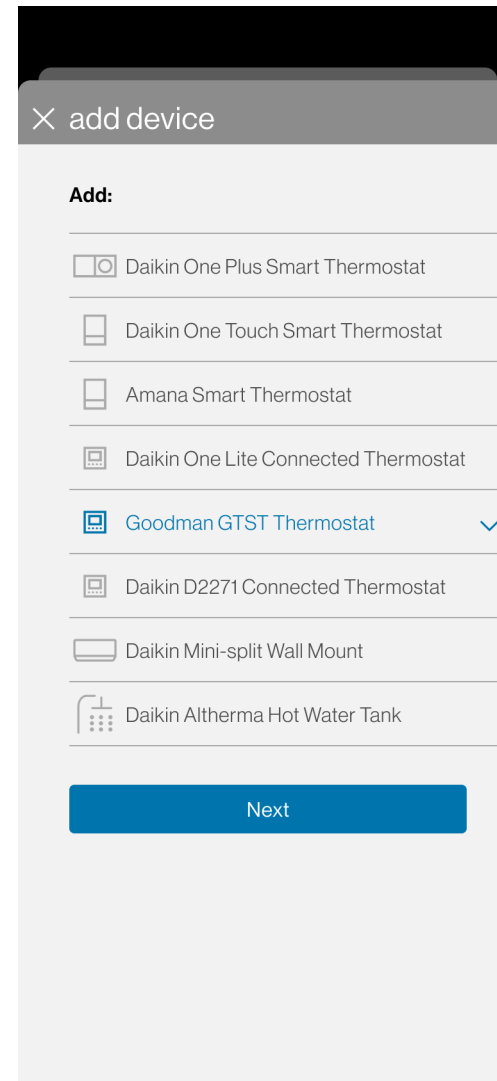
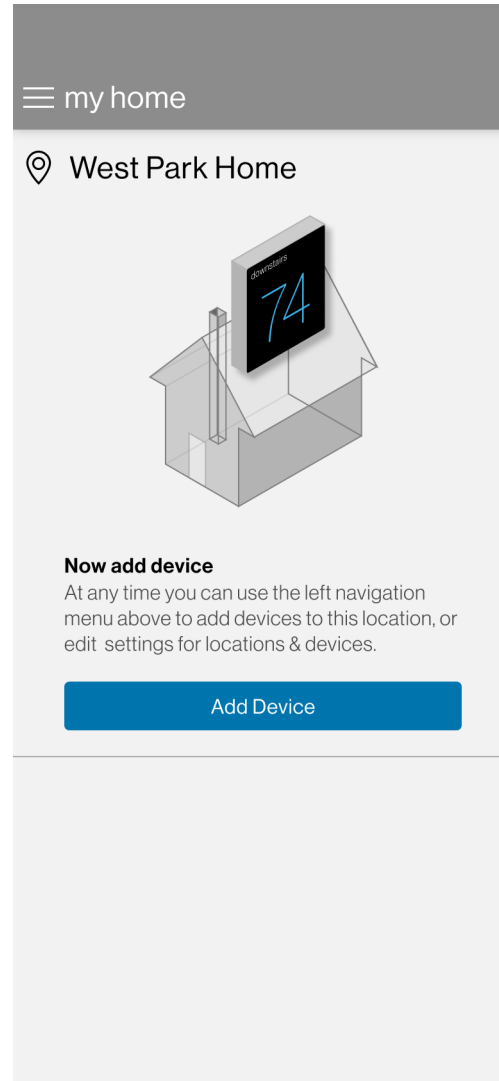

Connecting The App. To The Thermostat (Cont.)

- On the thermostat, press the warmer button to reveal the six-digit code.
- Select next on the mobile app. after code appears.

< add device

In the thermostat

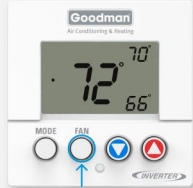

1. Press and hold the fan button for 5 seconds.



2. When WIRELESS SETUP appears on the display, release the fan button and press the warmer button.

Next

< add device



Enter the six digit number displayed on the thermostat screen.

Next

Connecting The App. To The Thermostat (Cont.)

- In the mobile app., enter the code displayed on the thermostat and select “add”.

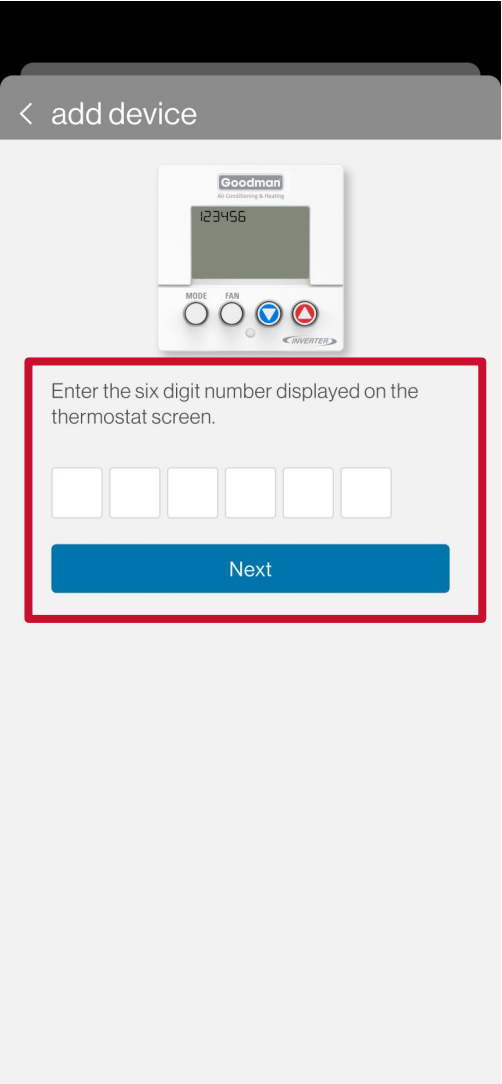

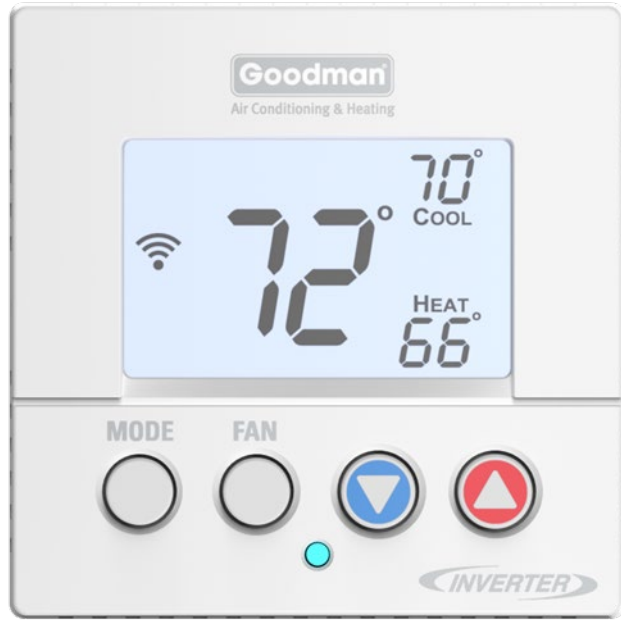

<https://www.goodmanmfg.com/products/controls>

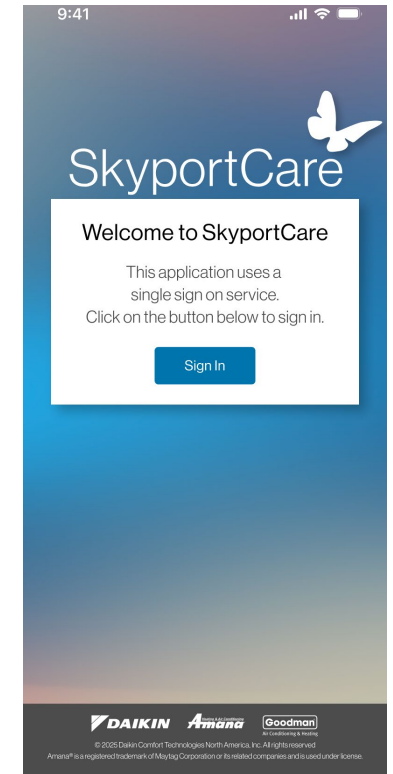
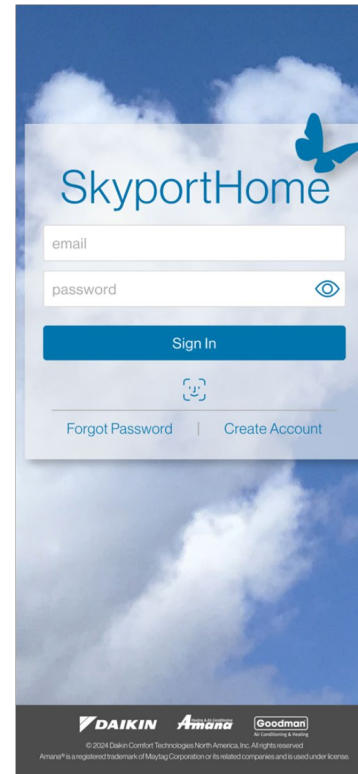
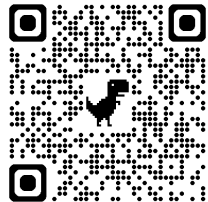

SCAN QR CODE FOR MORE INFORMATION ON SKYPORT:
<https://daikincomfort.com/products/cloud-services-apps/cloud-services---apps-homeowner>



Thank goodness for Goodman.®

