

SUBMITTAL DATA

FXU36HP230V1R32AH / FXU36HP230V1R32AO
36000 BTU/H Unitary Heat Pump Split System

Job Name	Location	Date
Purchaser	Engineer	
Submitted to	For	
Unit Designation	Schedule No.	

	
FXU36HP230V1R32AH	FXU36HP230V1R32AO

GENERAL FEATURES

- AHRI Certificate: [215213330](#)
- High Efficiency DC Inverter Technology
- 24VAC Thermostat Compatible
- Zero Lot Line Design
- Match with GREE or Competitive Indoor Unit
- New R32 Refrigerant
- Designed for New Construction or Replacement Market
- Low Ambient Cooling down to -15°C (5°F)
- Low Ambient Heating down to -30°C (-22°F)
- Coil (Outdoor) Copper Tube/Aluminum Fin with Anti-Corrosion Coil Coating (Gold Colored Fin - 1500Hr Salt Spray Rating)
- Coil (Indoor) Copper Tube/Aluminum Fin with Anti-Corrosion Coil Coating (Blue Colored Fin - 500Hr Salt Spray Rating)

SPECIFICATIONS, FEATURES & FUNCTION SUMMARY

SYSTEM TYPE		
Outdoor Model		FXU36HP230V1R32AO
Indoor Model		FXU36HP230V1R32AH
SYSTEM PERFORMANCE\$		
Cooling Capacity	Min - Max	Btu/h 21,542 - 39,600
	Capacity @95°F	Btu/h 34,000
Heating Capacity	Min - Max	Btu/h 19,592 - 36,040
	Capacity @47°F	Btu/h 34,000
	Capacity @17°F	Btu/h 28,200
	Capacity @5°F	Btu/h 34,000
SEER2		18.0
EER2		12.0
HSPF2		10.0
COP @5°F		2.0
Cooling Temperature Range		°F 5 - 129
Heating Temperature Range		°F -22 - 75
Refrigerant Type		R32
INDOOR UNIT		FXU36HP230V1R32AH
Power Supply	VAC	208-230V / 1Ph / 60 Hz
Sound Pressure Level	dB(A)	51
Control Voltage	VAC	24
Rated Current Cooling	A	1.6
Rated Current Heating	A	1.5
MCA	A	5.3
MOCP	A	15
Electric Heater (Optional)	kW	6, 9, 12
Air Flow	CFM	1000
External Static Pressure (Up to)	In W.c.	1.0
Dehumidification	pt/hr	/
External Dimensions (W x H x D)	in	21-1/4 x 48-3/16 x 21-1/4
Package Dimension (W x H x D)	in	23-3/4 x 50-3/8 x 26
Net Weight	lbs	163.1
Gross Weight	lbs	178.6
OUTDOOR UNIT		FXU36HP230V1R32AO
Power Supply	VAC	208-230V / 1Ph / 60 Hz
Sound Pressure Level	dB(A)	61
Control Voltage	VAC	24
Rated Current Cooling	A	14.89
Rated Current Heating	A	14.92
MCA	A	27.7
MOCP	A	30
Compressor Type	GREE G20 / Double Cylinder / 2 - Stage Inverter	
External Dimensions (W x H x D)	in	39 x 37-13/16 x 14-9/16
Package Dimension (W x H x D)	in	45-3/8 x 43-11/16 x 18-13/16
Net Weight	lbs	187.4
Gross Weight	lbs	211.6
Refrigerant Charge - R32	oz	102.3
Additional Charge	oz/ft	0.323
REFRIGERANT PIPING		
Line Set Size (Liquid - Gas) - Flared Connections	in	3/8 - 3/4
Pre-Charge Length	ft	31
Pipe Length (Min - Max)	ft	10 - 164
Max. Pipe Elevation	ft	98

FEATURES & FUNCTIONS SUMMARY	
Ultra Low Frequency Torque Control	Yes
Power Factor Correction	Yes
Outdoor Electronic Expansion Valve (EEV)	Yes
Indoor TXV Control	Yes
Basepan With Electric Heater	Yes
Compressor With Electric Heater	Yes
Fin Coating (Outdoor - Golden & Indoor - Blue)	Acrylic Resin
Intelligent Defrosting	Yes
Intelligent Preheating	Yes
Low Voltage Startup	Yes
Memory/Power Failure Recovery	Yes
Self Diagnosis	Yes
Low Ambient Cooling	Yes
24VAC Thermostat Compatible	Yes
Indoor Fan Type	Centrifugal
Multi Fan Speeds	5 Speeds
Auxiliary Electrical Heater	Optional

FAN PERFORMANCE

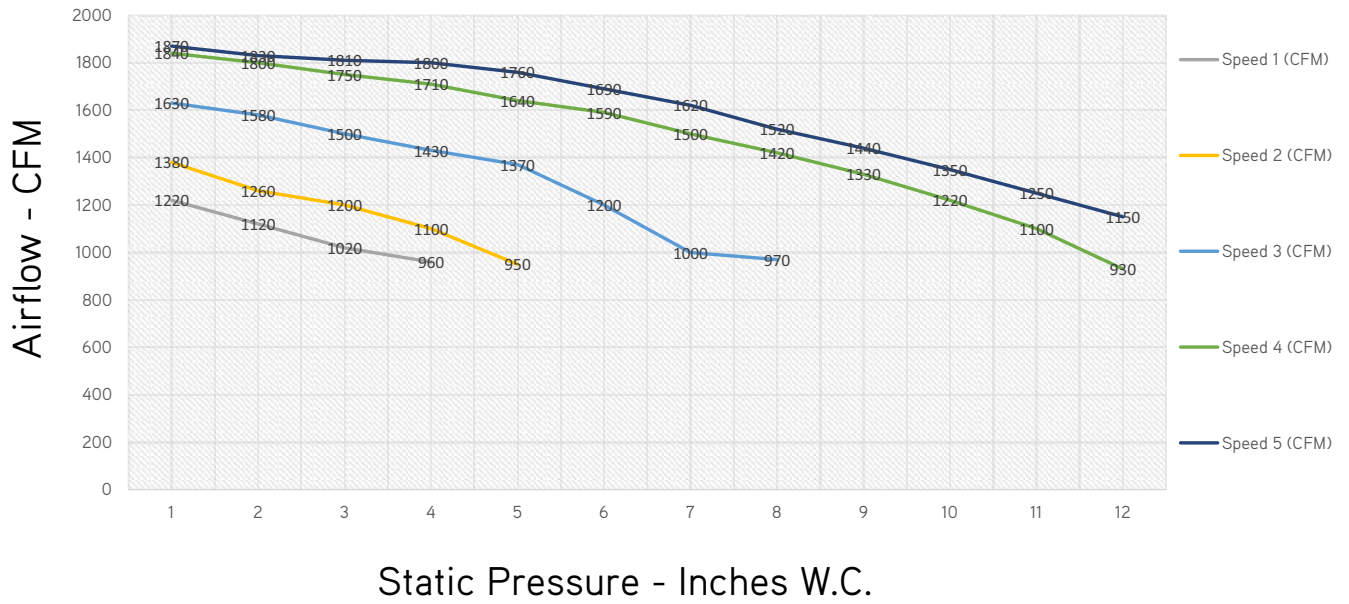

STATIC PRESSURE Inches W.C.	0	0.1	0.15	0.2	0.3	0.4	0.5	0.6	0.7	0.8	0.9	1.0
Speed 1 - CFM	1220	1120	1020	960								
Speed 2 - CFM	1380	1260	1200	1100	950							
Speed 3 - CFM	1630	1580	1500	1430	1370	1200	1000	970				
Speed 4 - CFM	1840	1800	1750	1710	1640	1590	1500	1420	1330	1220	1100	930
Speed 5 - CFM	1870	1830	1810	1800	1760	1690	1620	1520	1440	1350	1250	1150

NOTE:

1. Above chart CFM ratings are based on dry coil with factory filter installed.
2. For wet coil CFM ratings, multiply the CFM by 0.96 correction factor.

DIMENSIONS

INDOOR UNIT

Unit: inch

FXU36HP230V1R32AH	
DIMENSIONS	
A	11-5/8
B	20
H	48-3/16
W	21-1/4
D	21-1/4

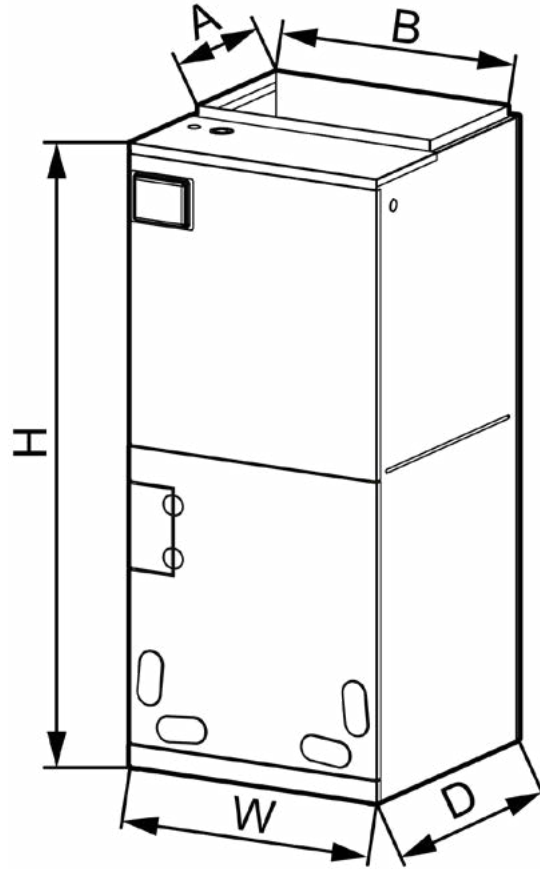

OUTDOOR UNIT

Unit: inch

FXU36HP230V1R32AO	
DIMENSIONS	
A	39
B	16-13/16
C	37-13/16
D	29-3/4
E	15-9/16
F	14-9/16

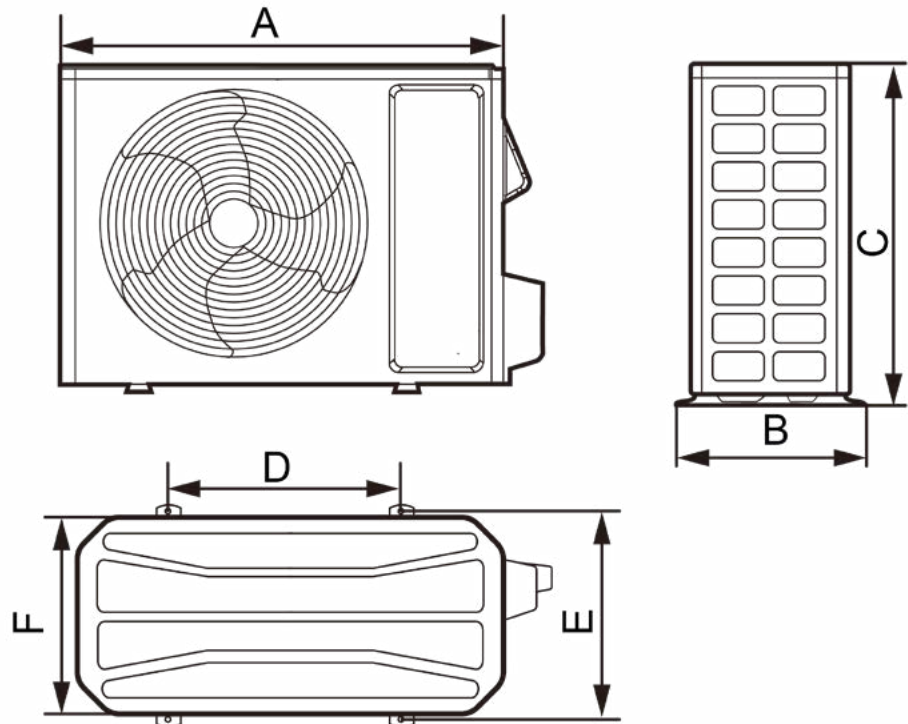

ACCESSORY HEATER AND GENERAL INFORMATION

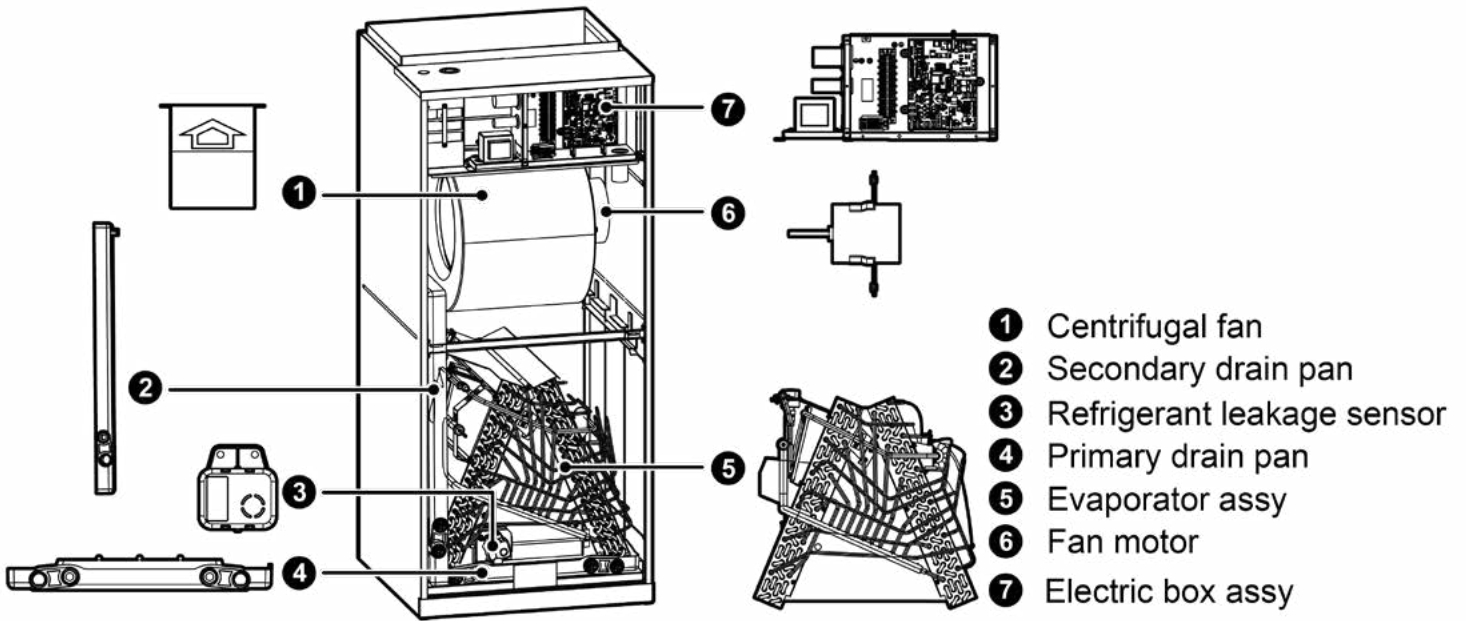

MODEL	Heat Kit Model	Part Number	Electric Heat (kW)		Min. Circuit Ampacity (A)				Max Fuse or Breaker (A)				
			208V	230V	208V		230V		208V		230V		
FXU36HP230V1R32AH	One Mains Supply												
	320004060223	FLEXA2LHTR06	3.74	4.6	31		33		35		35		
	Two Mains Supply												
						Power A	Power B	Power A	Power B	Power A	Power B	Power A	Power B
	320004060224	FLEXA2LHTR09	6.03	7.36	32.7	13.8	35.2	15	35	15	40	20	
320004060225	FLEXA2LHTR12	7.49	9.2	32.7	27.5	35.2	30	35	30	40	35		

CLEARANCES

INDOOR UNIT

Minimum clearance

FRONT > 24

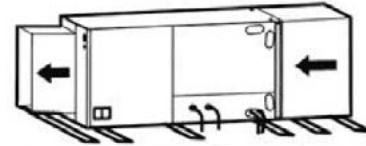
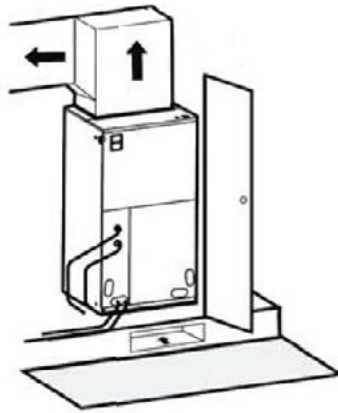

Horizontal Left Configuration - No Modification Needed

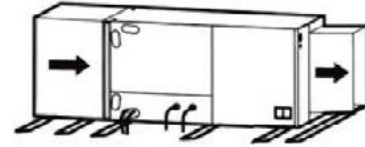

Horizontal Right Configuration - Must Relocate Drain Pan

NOTE:

Allow a minimum of 24" in front of the unit for service clearance. When installing in an area directly over a finished ceiling (such as an attic), an emergency drain pan is required directly under the unit. **See local and state codes for requirements.** When installing this unit in an area that may become wet, elevate the unit with a sturdy, non-porous material. In installations that may lead to physical damage (i.e. a garage) it is advised to install a protective barrier to prevent such damage. This air handler is designed for a complete supply and return ductwork system.

OUTDOOR UNIT

Minimum clearance

NOTE:
Install the Outdoor Unit **2 Inches**
Above the Expected Snow Line

1. When one outdoor unit is to be installed.

A - E	H_b H_d H		(in)				
			a	b	c	d	e
B	-	-	-	≥ 4	-	-	-
A, B, C	-	-	≥ 12	≥ 4	≥ 4	-	-
B, E	-	-	-	≥ 4	-	-	≥ 40
A, B, C, E	-	-	≥ 12	≥ 6	≥ 6	-	≥ 40
D	-	-	-	-	-	≥ 40	-
D, E	-	-	-	-	-	≥ 40	≥ 40
B, D	$H_b < H_d$	$H_d < H$	-	≥ 4	-	≥ 40	-
	$H_b > H_d$	$H_d > H$	-	≥ 4	-	≥ 40	-
B, D, E	$H_b < H_d$	$H_b \leq 1/2H$	-	≥ 10	-	≥ 80	≥ 40
		$1/2H < H_b \leq H$	-	≥ 10	-	≥ 80	≥ 40
	$H_b > H_d$	$H_b > H$	Prohibited				
		$H_b \leq 1/2H$	-	≥ 4	-	≥ 80	≥ 40
		$1/2H < H_b \leq H$	-	≥ 8	-	≥ 80	≥ 40
	$H_b > H$	Prohibited					

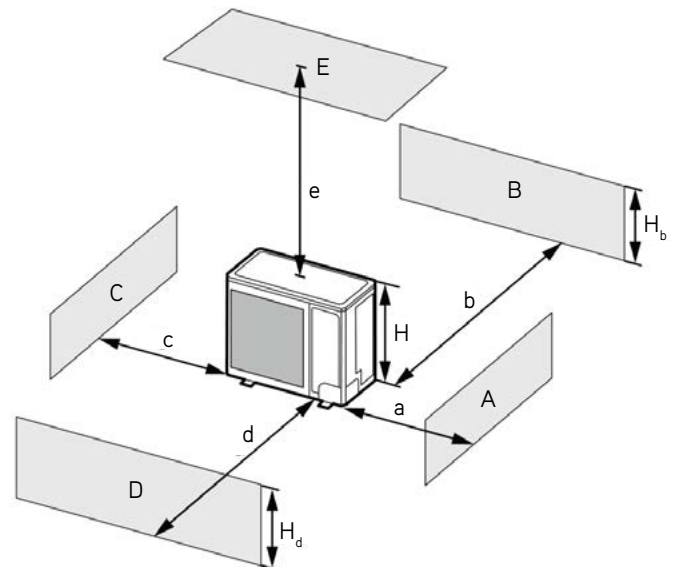

CLEARANCES

2. When two or more outdoor units are to be installed side by side.

A - E	H_b H_d H		(in)				
			a	b	c	d	e
A, B, C	-	-	≥ 12	≥ 12	≥ 40	-	-
A, B, C, E	-	-	≥ 12	≥ 12	≥ 40	-	≥ 40
D	-	-	-	-	-	≥ 80	-
D, E	-	-	-	-	-	≥ 80	≥ 40
B, D	$H_b < H_d$	$H_d > H$	-	≥ 12	-	≥ 80	-
	$H_b > H_d$	$H_d \leq 1/2H$	-	≥ 10	-	≥ 80	-
B, D, E	$H_b > H_d$	$1/2H < H_b \leq H$	-	≥ 12	-	≥ 100	-
		$H_b \leq 1/2H$	-	≥ 12	-	≥ 80	≥ 40
	$H_b < H_d$	$1/2H < H_b \leq H$	-	≥ 12	-	≥ 100	≥ 40
		$H_b > H$	Prohibited				
	$H_b > H_d$	$H_d \leq 1/2H$	-	≥ 10	-	≥ 100	≥ 40
		$1/2H < H_d \leq H$	-	≥ 12	-	≥ 100	≥ 40
	$H_d > H$	Prohibited					-

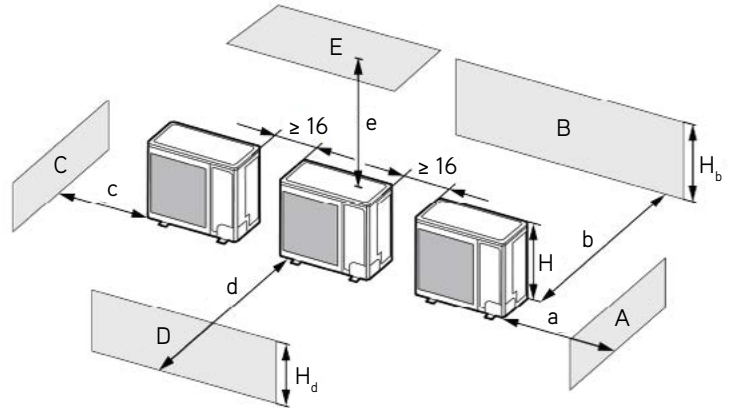

3. When outdoor units are installed in rows.

H_b H_d	(in)
$H_b \leq 1/2H$	$b \leq 10$
$1/2H < H_b \leq H$	$b \leq 12$
$H_b > H_d$	Prohibited

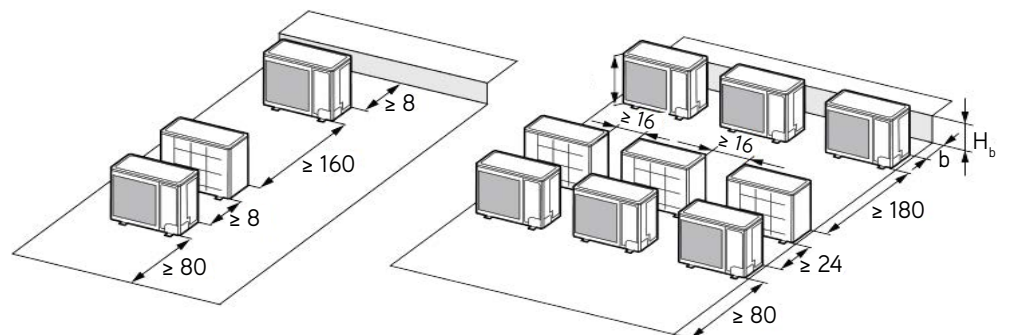

4. When outdoor units are installed one above another.

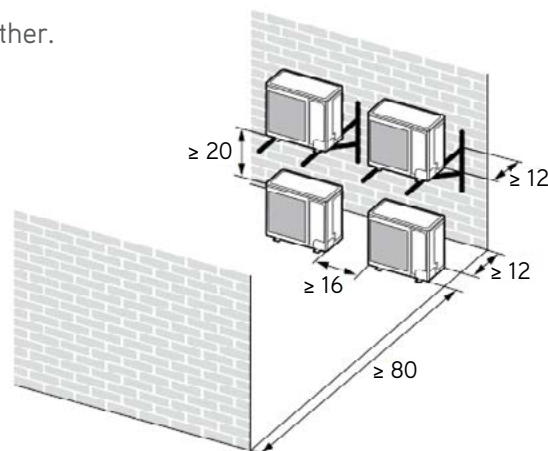

Specifications are subject to change without notice. Manufacturer reserves the right to discontinue or modify specifications or designs without notice or without incurring obligations. All Rights reserved.

GREECOMFORT.COM/SYSTEM-DOCUMENTATION