



R-32 Standard Efficiency Gas/Electric Direct-Drive Packaged Rooftop Unit 7.5-12.5 Ton DSG Light Commercial

7.5 - 10 Tons Up to 16 IEER / 12.0 EER

12.5 Tons 15.2 IEER / 11.4 EER



*Complete warranty details available from your local distributor or manufacturer's representative or at www.daikincomfort.com or www.daikinac.com



Our Perfect Package:

Harnessing energy-efficient performance, proven technology, and enhanced comfort for life.

Since becoming the first company in Japan to manufacture packaged air conditioning systems, in 1951, Daikin has supported comfortable indoor living based on the strengths and technologies that have led to the growth of the company becoming one of the world's largest manufacturers of HVAC products, systems and refrigerants.

Today, as a comprehensive global manufacturer of HVAC products and systems, the Daikin brand is committed to being recognized as a truly global and excellent company capable of continually creating new value for its customers. The company plans to pursue sustainable growth and foster business operations that consistently harmonize with the goals of improving indoor comfort.

The group philosophy of the company includes:

- » Creating new value continuously for customers
- » Developing world leading energy-saving technology
- » Being a flexible and dynamic organization
- » Allowing employees to be the driving force for the success of the company
- » Fostering an atmosphere of best practices, boldness, and innovation
- » Thinking and acting globally



Contents

2	Introduction	2
4	Nomenclature	4
5	Features and Benefits	5
	Applications	8
	Serviceability	8
9	Product Specifications	9
	Coil Dimension	19
	AHRI Ratings	19
	Sound Data	19
20	Dimensional Data	20
21	Expanding Cooling Data	21
29	Heating Data	29
30	Air Flow	30
79	Static Pressure	79
80	Electrical Data	80
83	Wiring Diagrams	83
84	Electrical Connections	84
	Unit Clearances	84
85	Installation	85
	Weights	85

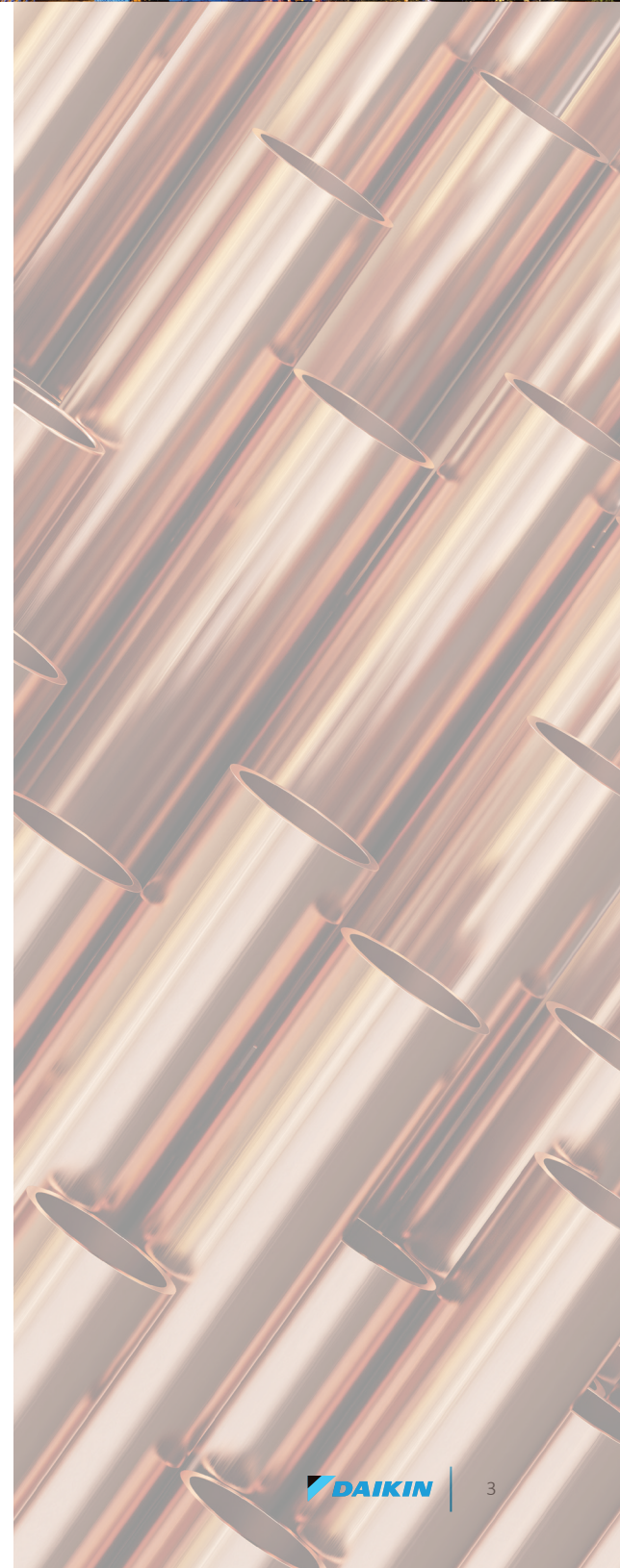

Nomenclature

	D	S	G	120	3	S	400	C	A	A	X	X	X	X	X	X	X	X	A *
	1	2	3	4,5,6	7	8	9,10,11	12	13	14	15	16	17	18	19	20	21	22	23 24
Brand	Revision Levels																		
D Daikin	Major & Minor																		
Configuration	X No Options																		
S R 32 Standard Efficiency	PE Connection																		
H R 32 High Efficiency	X No Options B Single-point power connection for Power Exhaust																		
Application	IAQ																		
C Cooling	X No Options																		
G Gas/Electric	Service Options																		
H Heat Pump	X No Option A Powered convenience outlet B Non-powered convenience outlet C Hinge Panels D Hinged Panels and Powered convenience outlet E Hinged Panels and non-powered convenience outlet																		
Nominal Cooling Capacity	Electrical																		
036 3 Tons 090 7½ Tons 180 15 Tons	X No Options A Non-Fused Disconnect B Phase Monitor C Thru-the-base connections E Non-Fused Disconnect and Phase Monitor F Non-Fused Disconnect and Thru-the-base connections H Phase Monitor and Thru-the-base connections L Non-Fused Disconnect, Thru-the-base connectons and Phase Monitor																		
048 4 Tons 102 8½ Tons 240 20 Tons	Economizer																		
060 5 Tons 120 10 Tons 300 25 Tons	X No Options A Ultra Low-Leak Downflow Economizer w/ Enthalpy Sensor C Ultra Low-Leak Internal Horizontal Economizer w/ Enthalpy Sensor E Ultra Low-Leak Downflow Economizer for DDC controls w/ Enthalpy Sensor F Ultra Low-Leak Horizontal Economizer for DDC controls w/ Enthalpy Sensor G Ultra Low-Leak Downflow Economizer w/ Dry Bulb Sensor J Ultra Low-Leak Internal Horizontal Economizer w/ Dry Bulb Sensor L Ultra Low-Leak Downflow Economizer for DDC controls w/ Dry Bulb Sensor M Ultra Low-Leak Horizontal Economizer for DDC controls w/ Dry Bulb Sensor																		
072 6 Tons 150 12½ tons	Coils, Hail guard																		
Voltage	Sensors																		
1 208-230/1/60 4 460/3/60	D R32 Sensor E RA Smoke Detector F SA Smoke Detector G RA & SA Smoke Detector																		
3 208-230/3/60 7 575/3/60																			
Supply Fan/Drive Type/Motor																			
D Direct Drive - Standard Static																			
W Direct Drive - High Static																			
L Direct Drive -Medium Static																			
Nominal Heating Capacity																			
Gas/Electric	A/C Factory-Installed Electric Heat																		
045 45,000 BTU/h XXX No Heat XXX No Heat																			
060 60,000 BTU/h 005 5kW 030 30 kW																			
070 70,000 BTU/h 010 10 kW 045 45kW																			
080 80,000 BTU/h 015 15 kW 060 60kW																			
090 90,000 BTU/h 020 20 kW 075 75kW																			
100 100,000 BTU/h 015 15 kW																			
115 115,000 BTU/h	Electric Heat w/ SCR controls																		
125 125,000 BTU/h	S05 5kW S22 20 kW																		
130 130,000 BTU/h	S10 10 kW S25 25 kW																		
140 140,000 BTU/h	S15 15 kW S30 30 kW																		
150 150,000 BTU/h	S16 15 kW S31 30 kW																		
180 180,000 BTU/h	S18 18 kW S45 45 kW																		
210 210,000 BTU/h	S20 20 kW S46 45 kW																		
225 225,000 BTU/h	S21 20 kW S60 60 kW																		
240 240,000 BTU/h	S21 20 kW S75 75kW																		
260 260,000 BTU/h																			
350 350,000 BTU/h																			
360 360,000 BTU/h	<i>See product specifications for heat size(s) available for each capacity.</i>																		
400 400,000 BTU/h																			
480 480,000 BTU/h																			
Refrigeration Systems																			
A Single stage cooling modes	G Single stage cooling mode with																		
C Two stage cooling modes	Low-ambient controller																		
F Two stage cooling modes with	H Two stage cooling mode with																		
Hot Gas Reheat and Low-ambient control	Low-ambient controller																		
Heat Exchanger																			
X No options																			
A Standard Aluminized Exchanger																			
S Stainless Steel Exchanger																			
U Ultra Low NoX																			
Controls																			
A Electro-mechanical controls																			
B DDC w/ BACnet interface																			

G/E Stocking Models

MODEL NUMBER	CODE STRING	MODEL NUMBER	CODE STRING
DSG0903D100001S	DSG0903D130CAADXXXXXXXXAA	DSG1204D100001S	DSG1204D240CAADXXXXXXXXAA
DSG0903DM00001S	DSG0903D180CAADXXXXXXXXAA	DSG1207D100001S	DSG1207D130CAADXXXXXXXXAA
DSG0903DH00001S	DSG0903D225CAADXXXXXXXXAA	DSG1207DM00001S	DSG1207D180CAADXXXXXXXXAA
DSG0904D100001S	DSG0904D130CAADXXXXXXXXAA	DSG1207DH00001S	DSG1207D240CAADXXXXXXXXAA
DSG0904DM00001S	DSG0904D180CAADXXXXXXXXAA	DSG1503D100001S	DSG1503D130CAADXXXXXXXXAA
DSG0904DH00001S	DSG0904D225CAADXXXXXXXXAA	DSG1503DM00001S	DSG1503D180CAADXXXXXXXXAA
DSG0907D100001S	DSG0907D130CAADXXXXXXXXAA	DSG1503DH00001S	DSG1503D240CAADXXXXXXXXAA
DSG0907DM00001S	DSG0907D180CAADXXXXXXXXAA	DSG1504D100001S	DSG1504D130CAADXXXXXXXXAA
DSG0907DH00001S	DSG0907D225CAADXXXXXXXXAA	DSG1504DM00001S	DSG1504D180CAADXXXXXXXXAA
DSG1023D100001S	DSG1023D130CAADXXXXXXXXAA	DSG1504DH00001S	DSG1504D240CAADXXXXXXXXAA
DSG1023DM00001S	DSG1023D180CAADXXXXXXXXAA	DSG1507D100001S	DSG1507D130CAADXXXXXXXXAA
DSG1023DH00001S	DSG1023D225CAADXXXXXXXXAA	DSG1507DM00001S	DSG1507D180CAADXXXXXXXXAA
DSG1024D100001S	DSG1024D130CAADXXXXXXXXAA	DSG1507DH00001S	DSG1507D240CAADXXXXXXXXAA
DSG1024DM00001S	DSG1024D180CAADXXXXXXXXAA	DSG1503WL00001F	DSG1503D130CAADXXXXXXXXAA
DSG1024DH00001S	DSG1024D225CAADXXXXXXXXAA	DSG1503WM00001F	DSG1503D180CAADXXXXXXXXAA
DSG1027D100001S	DSG1027D130CAADXXXXXXXXAA	DSG1503WH00001F	DSG1503D240CAADXXXXXXXXAA
DSG1027DM00001S	DSG1027D180CAADXXXXXXXXAA	DSG1504D100001F	DSG1504D130CAADXXXXXXXXAA
DSG1027DH00001S	DSG1027D225CAADXXXXXXXXAA	DSG1504DM00001F	DSG1504D180CAADXXXXXXXXAA
DSG1203D100001S	DSG1203D130CAADXXXXXXXXAA	DSG1504WH00001F	DSG1504D240CAADXXXXXXXXAA
DSG1203DM00001S	DSG1203D180CAADXXXXXXXXAA	DSG1507D100001F	DSG1507D130CAADXXXXXXXXAA
DSG1203DH00001S	DSG1203D240CAADXXXXXXXXAA	DSG1507DM00001F	DSG1507D180CAADXXXXXXXXAA
DSG1204D100001S	DSG1204D130CAADXXXXXXXXAA	DSG1507WH00001F	DSG1507D240CAADXXXXXXXXAA
DSG1204DM00001S	DSG1204D180CAADXXXXXXXXAA		

Features and Benefits

Daikin Packaged Rooftop Units (RTUs) are built to perform, with features and options that help provide low installation and operation costs, superior indoor air quality, efficient operation, and longevity.

Installation

Daikin Packaged units are designed with fast and easy installation in mind and are ideal for both new construction and retrofit projects. Our packaged rooftop units are built to be a direct replacement for most rooftop units on the field without the need of a curb adapter, to be able to replace the unit in a shorter time and at a lower cost (compared to the previous design).

Cabinet Construction

Daikin packaged rooftop units are made with high quality galvanized steel with a powder-paint finish to provide higher corrosion resistance.

- » Easy accessibility using our tool-less filter access
- » The interior surface in the indoor air section is fully insulated to prevent sweating and thermal losses, using our foil face fiberglass insulation which also omits exposed filter fibers into the airstream.
- » 1" Raised flanged edges around the supply and return offer easy installation for the duct connections.

- » The full perimeter base rail is built using heavy gauge galvanized steel for a stronger structural installation. The base rails are a minimum of 3½" tall and include holes to allow for overhead rigging and lifting with forklifts.

- » Electrical lines and gas lines can be brought through the base of the unit or through the horizontal knockout for easy installation and accessibility on the field.

Compressor

High performance, low noise scroll compressors to match the required total load.

- » Resiliently factory-mounted on rubber grommets for vibration isolation
- » Refrigeration circuits include both low- and high-pressure safety switches.
- » Unit is factory charged with environmentally friendly Low GWP R32 refrigerant.
- » Compressor location outside the condenser section to avoid air bypass.
- » Internal overload protection included with compressor.
- » Two single-stage scroll compressor for partial load applications.

Supply Fan

Indoor fan motors are direct drive EEM motors as standard to provide easy adjustment for airflow control.

- » Slide out forward curb fan for easy maintenance and replacement.
- » High-static drive options for application with high airflow/static requirements.
- » Each fan assembly is dynamically trim balanced at the factory before shipment for quick start-up and efficient operation.
- » Motor with thermal overload failure protection is provided for motor long lasting operation.
- » Ball bearing Direct-Drive EEM motor removes the need for belts, sheaves, bearings and lubrication.

Coils

All units use large face area outdoor coils. These coils are constructed with seamless copper tubes, mechanically bonded into aluminum plate-type fins with full drawn collars to completely cover the tubes for high operating efficiencies.

The indoor coil section is installed in a draw through configuration to provide better dehumidification.



Features and Benefits

- » Microchannel heat exchanger technology on all condenser coils for improved performance and reduced refrigerant load.
- » All units use large face area outdoor coils.
- » Coils are factory pressure tested to ensure pressure and leak integrity.
- » Copper tube / aluminum fin coils on evaporator
- » The furnace has a tubular design with in-shot gas burner manifold and is installed downstream of the supply fan.
- » The module contains an induced draft fan that will maintain a negative pressure in the heat exchanger tubes for the removal of the flue gases to protect indoor air quality.
- » Burner section provides flame roll-out safety protection switches and a high temperature limit switch for reliable operation.

Controls and Wiring

Packaged rooftop units come equipped with a well-organized, large, easy to use, weatherproof internal control box with easy access, for a better user experience.

- » Units are factory-wired with color-coded wires and complete 24-volt Electromechanical controls package.
- » Units include single-point power entry as standard.
- » Terminal blocks are provided as standard for easy installation and field power wiring.
- » Induced draft fan includes an airflow safety switch to prevent heating operation in the event of no airflow for occupant safety.
- » All burner assemblies are factory tested and adjusted prior to shipment.
- » Heating control is fully integrated into the unit's control system for quick start-up and reliable control.
- » Optional field installed LP kits are available for staged heating modules as well as high altitude kits.

Filtration

Unit provides a draw-through filter section as standard for better air quality and long lasting component maintenance.

- » Filters installed on the units are standard off the shelf sizes for easy replacement.
- » Tool-less filter access for easy and fast filter replacement and service.

Heating Section

Wide range of natural gas selections effectively handle most comfort heating demand from morning warm-up control to full heat, all available with Daikin's Wrinkle Bend heat exchanger technology.

Gas Furnace

ETL certified heating modules provide a custom match to specific design requirement.

- » Wrinkle Bend Technology available on all Daikin gas heat exchangers. The Wrinkle Bend Technology reduces the manufacturing stress that leads to defects and pinholes in the tubes at the same time as it increases the gas turbulence to amplify the heat transfer.
- » All 3-Phase models have a minimum 80% T.E. (Thermal Efficiency)
- » User has the flexibility to order heat exchanger tubes with 20 Gauge, G160, aluminized steel or stainless steel to meet your application needs.
- » Wiring complies with NEC requirements and all applicable UL standards.
- » For ease of use, wiring and electrical components are number coded and labeled according to the electrical diagram.
- » A 115 V GFI convenience outlet requiring independent power supply for the receptacle is optional.
- » An optional unit powered 20 amp 115 V convenience outlet, complete with factory mounted transformer, disconnect switch, and primary and secondary overload protection, eliminates the need to pull a separate 115 V power source.
- » Supply air fan, compressor, and condenser fan motor branch circuits have individual short circuit protection. Unit includes knockouts in the bottom of the main control panels for field wiring entrance.
- » A single-point power connection with power block is standard and a terminal board is provided for connecting low voltage control wiring.
- » For better serviceability an optional non-fused disconnect switch can be installed inside the control panel and operated by an externally mounted handle to disconnect the electrical power at the unit.

Electrical

Units are completely wired and tested at the factory to provide faster commissioning and start-up.



Applications

Daikin Rooftop units are intended for comfort cooling applications in normal heating, ventilating, and air conditioning. Consult your local Daikin sales representative for applications involving operations at high ambient temperatures, high altitudes, non-cataloged voltages, or for job-specific unit selections that fall outside of the range of the catalog tables.

For proper operation, units should be rigged in accordance with instructions stated on the installation manual. Fire dampers, if required, must be installed in the ductwork according to local and/or state codes. No space is allowed for these dampers in the unit.

Follow factory check, test and start procedures explicitly to achieve satisfactory start-up and operation.

Most rooftop applications take advantage of the significant energy savings provided with economizer operation. When an economizer system is used, mechanical refrigeration is typically not required below an ambient temperature of 50°F.

Serviceability

Daikin packaged rooftop units are built with serviceability in mind, designed to make future maintenance and service on the unit easy and accessible.

- » Our packaged rooftop units offer a slide out blower to facilitate the access and removal of the fan.
- » Filter panels on the small chassis line offer tool-less access for easy maintenance.
- » Independent compressor outside of the air bypass to eliminate component blockage and provide easy access.
- » Field connections are color coded to identify point-to-point component connections.
- » All 7.5- 12.5 ton units are designed for convertible airflow orientation to serve downflow or horizontal applications. Every unit ships prepared to convert to horizontal orientation in the field if required.
- » Easy access to gas valves and control panel.



Model	DSG0903DL00001S	DSG0903DM00001S	DSG0903DH00001S	DSG0904DL00001S	DSG0904DM00001S
COOLING CAPACITY					
Total, BTU/h	90,000	90,000	90,000	90,000	90,000
IEER / EER	16.0/12.0	16.0/12.0	16.0/12.0	16.0/12.0	16.0/12.0
SEER2 / EER2	N/A	N/A	N/A	N/A	N/A
AHRI Reference #					
HEATING CAPACITY					
Heat Range	LOW	MEDIUM	HIGH	LOW	MEDIUM
No. of Burners	5	6	7	5	6
High Stage Input / Output (KBTU/H)	130/105.3	180/145.8	225/182.25	130/105.3	180/145.8
Low Stage Input / Output (KBTU/H)	97.5/79	135/109.4	168.8/136.7	97.5/79	135/109.4
Thermal Efficiency (T.E.)	81%	81%	81%	81%	81%
Annual Fuel Utilization Efficiency (AFUE)	N/A	N/A	N/A	N/A	N/A
High Stage Temperature Rise Range (°F)	25-55	25-55	30-60	25-55	25-55
Low Stage Temperature Rise Range (°F)	25-55	25-55	30-60	25-55	25-55
EVAPORATOR MOTOR / RTPF (ROUND TUBE PLATE FIN)					
Motor Type	Direct Drive	Direct Drive	Direct Drive	Direct Drive	Direct Drive
External Static Pressure (ESP)	Standard	Standard	Standard	Standard	Standard
Wheel Dia. X Width	15x12	15x12	15x12	15x12	15x12
Indoor Nominal CFM	3020	3020	3020	3020	3020
RPM	300-1600	300-1600	300-1600	300-1600	300-1600
Indoor Horsepower	2.4	2.4	2.4	2.4	2.4
Filter Size (in)	20 X 20 X 2 (2) 20 X 25 X 2 (2)	20 X 20 X 2 (2) 20 X 25 X 2 (2)	20 X 20 X 2 (2) 20 X 25 X 2 (2)	20 X 20 X 2 (2) 20 X 25 X 2 (2)	20 X 20 X 2 (2) 20 X 25 X 2 (2)
Drain Size (NPT)	3/4	3/4	3/4	3/4	3/4
R-32 Refrigerant Charge (oz.)	53/53	53/53	53/53	53/53	53/53
Evaporator Coil Face Area (ft ²)	13.3	13.3	13.3	13.3	13.3
Rows Deep/ Fins per Inch	2 / 16	2 / 16	2 / 16	2 / 16	2 / 16
CONDENSER FAN / MCHX (MICROCHANNEL HEAT EXCHANGER)					
Quantity of Condenser Fan Motors	2	2	2	2	2
RPM (High/Low stage)	1122	1122	1122	1050	1050
Outdoor Horsepower	1/3	1/3	1/3	1/3	1/3
Fan Diameter/ # Fan Blades	22 / 3	22 / 3	22 / 3	22 / 3	22 / 3
Face Area (ft ²)	29.1	29.1	29.1	29.1	29.1
Rows Deep / Fins per Inch	1 / 23	1 / 23	1 / 23	1 / 23	1 / 23
COMPRESSOR					
Quantity / Type / Stages per Compressor	2/ Scroll / 1	2/ Scroll / 1	2/ Scroll / 1	2/ Scroll / 1	2/ Scroll / 1
Compressor RLA / LRA	12.2/120	12.2/120	12.2/120	5.8/55.1	5.8/55.1
ELECTRICAL DATA					
Voltage-Phase-Frequency	208/230-3-60	208/230-3-60	208/230-3-60	460-3-60	460-3-60
Indoor Blower FLA	8	8	8	5.4	5.4
Max External Static (In. W.C.)	0.8	0.8	0.8	0.8	0.8
Outdoor Fan FLA	2	2	2	0.85	0.85
Min. Circuit Ampacity ¹	39.4/39.4	39.4/39.4	39.4/39.4	20.1	20.1
Max. Overcurrent Protection (A) ²	50/50	50/50	50/50	25	25
Power Supply Conduit Hole Dia. (in)	1.375	1.375	1.375	1.375	1.375
Low-Voltage Conduit Hole Dia. (in)	0.5	0.5	0.5	0.5	0.5
OPERATING WEIGHT (LBS.)					
Operating Weight (lbs)	1106	1106	1106	1118	1118
SHIPPING WEIGHT (LBS.)					
Ship Weight (lbs)	1178	1178	1178	1190	1190

¹ Wire size should be determined in accordance with National Electrical Codes. Extensive wire runs will require larger wire sizes.

² May use fuses or HACR-type circuit breakers of the same size as noted.

Note: Always check the S&R plate for electrical data on the unit being installed.

Model	DSG0904DH00001S	DSG0907DL00001S	DSG0907DM00001S	DSG0907DH00001S
COOLING CAPACITY				
Total, BTU/h	90,000	90,000	90,000	90,000
IEER / EER	16.0/12.0	16.0/12.0	16.0/12.0	16.0/12.0
SEER2 / EER2	N/A	N/A	N/A	N/A
AHRI Reference #				
HEATING CAPACITY				
Heat Range	HIGH	LOW	MEDIUM	HIGH
No. of Burners	7	5	6	7
High Stage Input / Output (KBTU/H)	225/182.25	130/105.3	180/145.8	225/182.25
Low Stage Input / Output (KBTU/H)	168.8/136.7	97.5/79	135/109.4	168.8/136.7
Thermal Efficiency (T.E.)	81%	81%	81%	81%
Annual Fuel Utilization Efficiency (AFUE)	N/A	N/A	N/A	N/A
High Stage Temperature Rise Range (°F)	30-60	25-55	25-55	30-60
Low Stage Temperature Rise Range (°F)	30-60	25-55	25-55	30-60
EVAPORATOR MOTOR / RTPF (ROUND TUBE PLATE FIN)				
Motor Type	Direct Drive	Direct Drive	Direct Drive	Direct Drive
External Static Pressure (ESP)	Standard	Standard	Standard	Standard
Wheel Dia. X Width	15x12	15x12	15x12	15x12
Indoor Nominal CFM	3020	3020	3020	3020
RPM	300-1600	300-1600	300-1600	300-1600
Indoor Horsepower	2.4	2.4	2.4	2.4
Filter Size (in)	20 X 20 X 2 (2) 20 X 25 X 2 (2)	20 X 20 X 2 (2) 20 X 25 X 2 (2)	20 X 20 X 2 (2) 20 X 25 X 2 (2)	20 X 20 X 2 (2) 20 X 25 X 2 (2)
Drain Size (NPT)	3/4	3/4	3/4	3/4
R-32 Refrigerant Charge (oz.)	53/53	53/53	53/53	53/53
Evaporator Coil Face Area (ft ²)	13.3	13.3	13.3	13.3
Rows Deep/ Fins per Inch	2 / 16	2 / 16	2 / 16	2 / 16
CONDENSER FAN / MCHX (MICROCHANNEL HEAT EXCHANGER)				
Quantity of Condenser Fan Motors	2	2	2	2
RPM (High/Low stage)	1050	1050	1050	1050
Outdoor Horsepower	1/3	1/3	1/3	1/3
Fan Diameter/ # Fan Blades	22 / 3	22 / 3	22 / 3	22 / 3
Face Area (ft ²)	29.1	29.1	29.1	29.1
Rows Deep / Fins per Inch	1 / 23	1 / 23	1 / 23	1 / 23
COMPRESSOR				
Quantity / Type / Stages per Compressor	2/ Scroll / 1	2/ Scroll / 1	2/ Scroll / 1	2/ Scroll / 1
Compressor RLA / LRA	5.8/55.1	5.8/41	5.8/41	5.8/41
ELECTRICAL DATA				
Voltage-Phase-Frequency	460-3-60	575-3-60	575-3-60	575-3-60
Indoor Blower FLA	5.4	4.0	4.0	4.0
Max External Static (In. W.C.)	0.8	0.8	0.8	0.8
Outdoor Fan FLA	0.85	0.67	0.67	0.67
Min. Circuit Ampacity ¹	20.1	18.3	18.3	18.3
Max. Overcurrent Protection (A) ²	25	20	20	20
Power Supply Conduit Hole Dia. (in)	1.375	1.375	1.375	1.375
Low-Voltage Conduit Hole Dia. (in)	0.5	0.5	0.5	0.5
OPERATING WEIGHT (LBS.)				
Operating Weight (lbs)	1106	1118	1118	1118
SHIPPING WEIGHT (LBS.)				
Ship Weight (lbs)	1178	1190	1190	1190

¹ Wire size should be determined in accordance with National Electrical Codes. Extensive wire runs will require larger wire sizes.

² May use fuses or HACR-type circuit breakers of the same size as noted.

Note: Always check the S&R plate for electrical data on the unit being installed.

Model	DSG1023DL00001S	DSG1023DM00001S	DSG1023DH00001S	DSG1024DL00001S	DSG1024DM00001S
COOLING CAPACITY					
Total, BTU/h	97,000	97,000	97,000	97,000	97,000
IEER / EER	14.8/11.2	14.8/11.2	14.8/11.2	14.8/11.2	14.8/11.2
SEER2 / EER2	N/A	N/A	N/A	N/A	N/A
AHRI Reference #					
HEATING CAPACITY					
Heat Range	LOW	MEDIUM	HIGH	LOW	MEDIUM
No. of Burners	5	6	7	5	6
High Stage Input / Output (KBTU/H)	130/105.3	180/145.8	225/182.25	130/105.3	180/145.8
Low Stage Input / Output (KBTU/H)	97.5/79	135/109.4	168.8/136.7	97.5/79	135/109.4
Thermal Efficiency (T.E.)	81%	81%	81%	81%	81%
Annual Fuel Utilization Efficiency (AFUE)	N/A	N/A	N/A	N/A	N/A
High Stage Temperature Rise Range (°F)	25-55	25-55	30-60	25-55	25-55
Low Stage Temperature Rise Range (°F)	25-55	25-55	30-60	25-55	25-55
EVAPORATOR MOTOR / RTPF (ROUND TUBE PLATE FIN)					
Motor Type	Direct Drive	Direct Drive	Direct Drive	Direct Drive	Direct Drive
External Static Pressure (ESP)	Standard	Standard	Standard	Standard	Standard
Wheel Dia. X Width	15x12	15x12	15x12	15x12	15x12
Indoor Nominal CFM	3230	3230	3230	3230	3230
RPM	300-1600	300-1600	300-1600	300-1600	300-1600
Indoor Horsepower	2.4	2.4	2.4	2.4	2.4
Filter Size (in)	20 X 20 X 2 (2) 20 X 25 X 2 (2)	20 X 20 X 2 (2) 20 X 25 X 2 (2)	20 X 20 X 2 (2) 20 X 25 X 2 (2)	20 X 20 X 2 (2) 20 X 25 X 2 (2)	20 X 20 X 2 (2) 20 X 25 X 2 (2)
Drain Size (NPT)	3/4	3/4	3/4	3/4	3/4
R-32 Refrigerant Charge (oz.)	56/56	56/56	56/56	56/56	56/56
Evaporator Coil Face Area (ft ²)	13.3	13.3	13.3	13.3	13.3
Rows Deep/ Fins per Inch	2 / 16	2 / 16	2 / 16	2 / 16	2 / 16
CONDENSER FAN / MCHX (MICROCHANNEL HEAT EXCHANGER)					
Quantity of Condenser Fan Motors	2	2	2	2	2
RPM (High/Low stage)	1122	1122	1122	1050	1050
Outdoor Horsepower	1/3	1/3	1/3	1/3	1/3
Fan Diameter/ # Fan Blades	22 / 3	22 / 3	22 / 3	22 / 3	22 / 3
Face Area (ft ²)	29.1	29.1	29.1	29.1	29.1
Rows Deep / Fins per Inch	1 / 23	1 / 23	1 / 23	1 / 23	1 / 23
COMPRESSOR					
Quantity / Type / Stages per Compressor	2/ Scroll / 1	2/ Scroll / 1	2/ Scroll / 1	2/ Scroll / 1	2/ Scroll / 1
Compressor RLA / LRA	14.1/120	14.1/120	14.1/120	6.4/55.1	6.4/55.1
ELECTRICAL DATA					
Voltage-Phase-Frequency	208/230-3-60	208/230-3-60	208/230-3-60	460-3-60	460-3-60
Indoor Blower FLA	8	8	8	5.4	5.4
Max External Static (In. W.C.)	0.8	0.8	0.8	0.8	0.8
Outdoor Fan FLA	2	2	2	0.85	0.85
Min. Circuit Ampacity ¹	43.7/43.7	43.7/43.7	43.7/43.7	21.5	21.5
Max. Overcurrent Protection (A) ²	50 / 50	50 / 50	50 / 50	25	25
Power Supply Conduit Hole Dia. (in)	1.375	1.375	1.375	1.375	1.375
Low-Voltage Conduit Hole Dia. (in)	0.5	0.5	0.5	0.5	0.5
OPERATING WEIGHT (LBS.)					
Operating Weight (lbs)	1118	1118	1118	1118	1118
SHIPPING WEIGHT (LBS.)					
Ship Weight (lbs)	1190	1190	1190	1190	1190

¹ Wire size should be determined in accordance with National Electrical Codes. Extensive wire runs will require larger wire sizes.

² May use fuses or HACR-type circuit breakers of the same size as noted.

Note: Always check the S&R plate for electrical data on the unit being installed.

Model	DSG1024DH00001S	DSG1027DL00001S	DSG1027DM00001S	DSG1027DH00001S
COOLING CAPACITY				
Total, BTU/h	97,000	97,000	97,000	97,000
IEER / EER	14.8/11.2	14.8/11.2	14.8/11.2	14.8/11.2
SEER2 / EER2	N/A	N/A	N/A	N/A
AHRI Reference #				
HEATING CAPACITY				
Heat Range	HIGH	LOW	MEDIUM	HIGH
No. of Burners	7	5	6	7
High Stage Input / Output (KBTU/H)	225/182.25	130/105.3	180/145.8	225/182.25
Low Stage Input / Output (KBTU/H)	168.8/136.7	97.5/79	135/109.4	168.8/136.7
Thermal Efficiency (T.E.)	81%	81%	81%	81%
Annual Fuel Utilization Efficiency (AFUE)	N/A	N/A	N/A	N/A
High Stage Temperature Rise Range (°F)	30-60	25-55	25-55	30-60
Low Stage Temperature Rise Range (°F)	30-60	25-55	25-55	30-60
EVAPORATOR MOTOR / RTPF (ROUND TUBE PLATE FIN)				
Motor Type	Direct Drive	Direct Drive	Direct Drive	Direct Drive
External Static Pressure (ESP)	Standard	Standard	Standard	Standard
Wheel Dia. X Width	15x12	15x12	15x12	15x12
Indoor Nominal CFM	3230	3230	3230	3230
RPM	300-1600	300-1600	300-1600	300-1600
Indoor Horsepower	2.4	2.4	2.4	2.4
Filter Size (in)	20 X 20 X 2 (2) 20 X 25 X 2 (2)	20 X 20 X 2 (2) 20 X 25 X 2 (2)	20 X 20 X 2 (2) 20 X 25 X 2 (2)	20 X 20 X 2 (2) 20 X 25 X 2 (2)
Drain Size (NPT)	3/4	3/4	3/4	3/4
R-32 Refrigerant Charge (oz.)	56/56	56/56	56/56	56/56
Evaporator Coil Face Area (ft²)	13.3	13.3	13.3	13.3
Rows Deep/ Fins per Inch	2 / 16	2 / 16	2 / 16	2 / 16
CONDENSER FAN / MCHX (MICROCHANNEL HEAT EXCHANGER)				
Quantity of Condenser Fan Motors	2	2	2	2
RPM (High/Low stage)	1050	1050	1050	1050
Outdoor Horsepower	1/3	1/3	1/3	1/3
Fan Diameter/ # Fan Blades	22 / 3	22 / 3	22 / 3	22 / 3
Face Area (ft²)	29.1	29.1	29.1	29.1
Rows Deep / Fins per Inch	1 / 23	1 / 23	1 / 23	1 / 23
COMPRESSOR				
Quantity / Type / Stages per Compressor	2/ Scroll / 1	2/ Scroll / 1	2/ Scroll / 1	2/ Scroll / 1
Compressor RLA / LRA	6.4/55.1	5.1/41	5.1/41	5.1/41
ELECTRICAL DATA				
Voltage-Phase-Frequency	460-3-60	575-3-60	575-3-60	575-3-60
Indoor Blower FLA	5.4	4.0	4.0	4.0
Max External Static (In. W.C.)	0.8	0.8	0.8	0.8
Outdoor Fan FLA	0.85	0.67	0.67	0.67
Min. Circuit Ampacity ¹	21.5	16.9	16.9	16.9
Max. Overcurrent Protection (A) ²	25	20	20	20
Power Supply Conduit Hole Dia. (in)	1.375	1.375	1.375	1.375
Low-Voltage Conduit Hole Dia. (in)	0.5	0.5	0.5	0.5
OPERATING WEIGHT (LBS.)				
Operating Weight (lbs)	1118	1118	1118	1118
SHIPPING WEIGHT (LBS.)				
Ship Weight (lbs)	1190	1190	1190	1190

¹ Wire size should be determined in accordance with National Electrical Codes. Extensive wire runs will require larger wire sizes.

² May use fuses or HACR-type circuit breakers of the same size as noted.

Note: Always check the S&R plate for electrical data on the unit being installed.

Model	DSG1203DL00001S	DSG1203DM00001S	DSG1203DH00001S	DSG1204DL00001S	DSG1204DM00001S
COOLING CAPACITY					
Total, BTU/h	116,000	116,000	116,000	116,000	116,000
IEER / EER	14.8/11.2	14.8/11.2	14.8/11.2	14.8/11.2	14.8/11.2
SEER2 / EER2	N/A	N/A	N/A	N/A	N/A
AHRI Reference #					
HEATING CAPACITY					
Heat Range	LOW	MEDIUM	HIGH	LOW	MEDIUM
No. of Burners	5	6	7	5	6
High Stage Input / Output (KBTU/H)	130/105.3	180/145.8	240/194.4	130/105.3	180/145.8
Low Stage Input / Output (KBTU/H)	97.5/79	135/109.4	180/145.8	97.5/79	135/109.4
Thermal Efficiency (T.E.)	81%	81%	81%	81%	81%
Annual Fuel Utilization Efficiency (AFUE)	N/A	N/A	N/A	N/A	N/A
High Stage Temperature Rise Range (°F)	25-55	25-55	30-60	25-55	25-55
Low Stage Temperature Rise Range (°F)	25-55	25-55	30-60	25-55	25-55
EVAPORATOR MOTOR / RTPF (ROUND TUBE PLATE FIN)					
Motor Type	Direct Drive	Direct Drive	Direct Drive	Direct Drive	Direct Drive
External Static Pressure (ESP)	Standard	Standard	Standard	Standard	Standard
Wheel Dia. X Width	15x15	15x15	15x15	15x15	15x15
Indoor Nominal CFM	3380	3380	3380	3380	3380
RPM	300-1600	300-1600	300-1600	300-1600	300-1600
Indoor Horsepower	3.5	3.5	3.5	3.5	3.5
Filter Size (in)	20 X 25 X 2 (2) 25 X 25 X 2 (2)	20 X 25 X 2 (2) 25 X 25 X 2 (2)	20 X 25 X 2 (2) 25 X 25 X 2 (2)	20 X 25 X 2 (2) 25 X 25 X 2 (2)	20 X 25 X 2 (2) 25 X 25 X 2 (2)
Drain Size (NPT)	3/4	3/4	3/4	3/4	3/4
R-32 Refrigerant Charge (oz.)	73/71	73/71	73/71	73/71	73/71
Evaporator Coil Face Area (ft ²)	16.2	16.2	16.2	16.2	16.2
Rows Deep/ Fins per Inch	3 / 16	3 / 16	3 / 16	3 / 16	3 / 16
CONDENSER FAN / MCHX (MICROCHANNEL HEAT EXCHANGER)					
Quantity of Condenser Fan Motors	2	2	2	2	2
RPM (High/Low stage)	1122	1122	1122	1050	1050
Outdoor Horsepower	1/3	1/3	1/3	1/3	1/3
Fan Diameter/ # Fan Blades	22 / 3	22 / 3	22 / 3	22 / 3	22 / 3
Face Area (ft ²)	29.1	29.1	29.1	29.1	29.1
Rows Deep / Fins per Inch	1 / 23	1 / 23	1 / 23	1 / 23	1 / 23
COMPRESSOR					
Quantity / Type / Stages per Compressor	2/ Scroll / 1	2/ Scroll / 1	2/ Scroll / 1	2/ Scroll / 1	2/ Scroll / 1
Compressor RLA / LRA	17.3/155	17.3/155	17.3/155	7.7/58.1	7.7/58.1
ELECTRICAL DATA					
Voltage-Phase-Frequency	208/230-3-60	208/230-3-60	208/230-3-60	460-3-60	460-3-60
Indoor Blower FLA	8	8	8	5.4	5.4
Max External Static (In. W.C.)	0.8	0.8	0.8	0.8	0.8
Outdoor Fan FLA	2	2	2	0.85	0.85
Min. Circuit Ampacity ¹	53.8/53.8	53.8/53.8	53.8/53.8	26.2	26.2
Max. Overcurrent Protection (A) ²	70/70	70/70	70/70	30	30
Power Supply Conduit Hole Dia. (in)	1.375	1.375	1.375	1.375	1.375
Low-Voltage Conduit Hole Dia. (in)	0.5	0.5	0.5	0.5	0.5
OPERATING WEIGHT (LBS.)					
Operating Weight (lbs)	1161	1161	1161	1161	1161
SHIPPING WEIGHT (LBS.)					
Ship Weight (lbs)	1199	1209	1219	1199	1209

¹ Wire size should be determined in accordance with National Electrical Codes. Extensive wire runs will require larger wire sizes.

² May use fuses or HACR-type circuit breakers of the same size as noted.

Note: Always check the S&R plate for electrical data on the unit being installed.

Model	DSG1204DH00001S	DSG1207DL00001S	DSG1207DM00001S	DSG1207DH00001S
COOLING CAPACITY				
Total, BTU/h	116,000	116,000	116,000	116,000
IEER / EER	14.8/11.2	14.8/11.2	14.8/11.2	14.8/11.2
SEER2 / EER2	N/A	N/A	N/A	N/A
AHRI Reference #				
HEATING CAPACITY				
Heat Range	HIGH	LOW	MEDIUM	HIGH
No. of Burners	7	5	6	7
High Stage Input / Output (KBTU/H)	240/194.4	130/105.3	180/145.8	240/194.4
Low Stage Input / Output (KBTU/H)	180/145.8	97.5/79	135/109.4	180/145.8
Thermal Efficiency (T.E.)	81%	81%	81%	81%
Annual Fuel Utilization Efficiency (AFUE)	N/A	N/A	N/A	N/A
High Stage Temperature Rise Range (°F)	30-60	25-55	25-55	30-60
Low Stage Temperature Rise Range (°F)	30-60	25-55	25-55	30-60
EVAPORATOR MOTOR / RTPF (ROUND TUBE PLATE FIN)				
Motor Type	Direct Drive	Direct Drive	Direct Drive	Direct Drive
External Static Pressure (ESP)	Standard	Standard	Standard	Standard
Wheel Dia. X Width	15x15	15x15	15x15	15x15
Indoor Nominal CFM	3380	3380	3380	3380
RPM	300-1600	300-1600	300-1600	300-1600
Indoor Horsepower	3.5	3.5	3.5	3.5
Filter Size (in)	20 X 25 X 2 (2) 25 X 25 X 2 (2)	20 X 25 X 2 (2) 25 X 25 X 2 (2)	20 X 25 X 2 (2) 25 X 25 X 2 (2)	20 X 25 X 2 (2) 25 X 25 X 2 (2)
Drain Size (NPT)	3/4	3/4	3/4	3/4
R-32 Refrigerant Charge (oz.)	73/71	73/71	73/71	73/71
Evaporator Coil Face Area (ft²)	16.2	16.2	16.2	16.2
Rows Deep/ Fins per Inch	3 / 16	3 / 16	3 / 16	3 / 16
CONDENSER FAN / MCHX (MICROCHANNEL HEAT EXCHANGER)				
Quantity of Condenser Fan Motors	2	2	2	2
RPM (High/Low stage)	1050	1050	1050	1050
Outdoor Horsepower	1/3	1/3	1/3	1/3
Fan Diameter/ # Fan Blades	22 / 3	22 / 3	22 / 3	22 / 3
Face Area (ft²)	29.1	29.1	29.1	29.1
Rows Deep / Fins per Inch	1 / 23	1 / 23	1 / 23	1 / 23
COMPRESSOR				
Quantity / Type / Stages per Compressor	2/ Scroll / 1	2/ Scroll / 1	2/ Scroll / 1	2/ Scroll / 1
Compressor RLA / LRA	7.7/58.1	7.0/47.8	7.0/47.8	7.0/47.8
ELECTRICAL DATA				
Voltage-Phase-Frequency	460-3-60	575-3-60	575-3-60	575-3-60
Indoor Blower FLA	5.4	4.0	4.0	4.0
Max External Static (In. W.C.)	0.8	0.8	0.8	0.8
Outdoor Fan FLA	0.85	0.67	0.67	0.67
Min. Circuit Ampacity ¹	26.2	22.2	22.2	22.2
Max. Overcurrent Protection (A) ²	30	25	25	25
Power Supply Conduit Hole Dia. (in)	1.375	1.375	1.375	1.375
Low-Voltage Conduit Hole Dia. (in)	0.5	0.5	0.5	0.5
OPERATING WEIGHT (LBS.)				
Operating Weight (lbs)	1161	1161	1161	1161
SHIPPING WEIGHT (LBS.)				
Ship Weight (lbs)	1233	1233	1233	1233

¹ Wire size should be determined in accordance with National Electrical Codes. Extensive wire runs will require larger wire sizes.

² May use fuses or HACR-type circuit breakers of the same size as noted.

Note: Always check the S&R plate for electrical data on the unit being installed.

Model	DSG1503DL00001S	DSG1503DM00001S	DSG1503DH00001S	DSG1504DL00001S	DSG1504DM00001S
COOLING CAPACITY					
Total, BTU/h	140,000	140,000	140,000	140,000	140,000
IEER / EER	14.2/11	14.2/11	14.2/11	14.2/11	14.2/11
SEER2 / EER2	N/A	N/A	N/A	N/A	N/A
AHRI Reference #					
HEATING CAPACITY					
Heat Range	LOW	MEDIUM	HIGH	LOW	MEDIUM
No. of Burners	5	6	7	5	6
High Stage Input / Output (KBTU/H)	130/105.3	180/145.8	240/194.4	130/105.3	180/145.8
Low Stage Input / Output (KBTU/H)	97.5/79	135/109.4	180/145.8	97.5/79	135/109.4
Thermal Efficiency (T.E.)	81%	81%	81%	81%	81%
Annual Fuel Utilization Efficiency (AFUE)	N/A	N/A	N/A	N/A	N/A
High Stage Temperature Rise Range (°F)	25-55	25-55	30-60	25-55	25-55
Low Stage Temperature Rise Range (°F)	25-55	25-55	30-60	25-55	25-55
EVAPORATOR MOTOR / RTPF (ROUND TUBE PLATE FIN)					
Motor Type	Direct Drive	Direct Drive	Direct Drive	Direct Drive	Direct Drive
External Static Pressure (ESP)	Standard	Standard	Standard	Standard	Standard
Wheel Dia. X Width	15x15	15x15	15x15	15x15	15x15
Indoor Nominal CFM	4200	4200	4200	4200	4200
RPM	300-1600	300-1600	300-1600	300-1600	300-1600
Indoor Horsepower	3.5	3.5	3.5	3.5	3.5
Filter Size (in)	20 X 25 X 2 (2) 25 X 25 X 2 (2)	20 X 25 X 2 (2) 25 X 25 X 2 (2)	20 X 25 X 2 (2) 25 X 25 X 2 (2)	20 X 25 X 2 (2) 25 X 25 X 2 (2)	20 X 25 X 2 (2) 25 X 25 X 2 (2)
Drain Size (NPT)	3/4	3/4	3/4	3/4	3/4
R-32 Refrigerant Charge (oz.)	110/111	110/111	110/111	110/111	110/111
Evaporator Coil Face Area (ft ²)	16.2	16.2	16.2	16.2	16.2
Rows Deep/ Fins per Inch	4 / 16	4 / 16	4 / 16	4 / 16	4 / 16
CONDENSER FAN / MCHX (MICROCHANNEL HEAT EXCHANGER)					
Quantity of Condenser Fan Motors	2	2	2	2	2
RPM (High/Low stage)	1130	1130	1130	1115	1115
Outdoor Horsepower	1/2	1/2	1/2	1/2	1/2
Fan Diameter/ # Fan Blades	22 / 3	22 / 3	22 / 3	22 / 3	22 / 3
Face Area (ft ²)	40.8	40.8	40.8	40.8	40.8
Rows Deep / Fins per Inch	1 / 23	1 / 23	1 / 23	1 / 23	1 / 23
COMPRESSOR					
Quantity / Type / Stages per Compressor	2/ Scroll / 1	2/ Scroll / 1	2/ Scroll / 1	2/ Scroll / 1	2/ Scroll / 1
Compressor RLA / LRA	19.2/157	19.2/157	19.2/157	9.0/74.8	9.0/74.8
ELECTRICAL DATA					
Voltage-Phase-Frequency	208/230-3-60	208/230-3-60	208/230-3-60	460-3-60	460-3-60
Indoor Blower FLA	10.9	10.9	10.9	7.2	7.2
Max External Static (In. W.C.)	0.8	0.8	0.8	0.8	0.8
Outdoor Fan FLA	2.7	2.7	2.7	1.4	1.4
Min. Circuit Ampacity ¹	59.5/59.5	59.5/59.5	59.5/59.5	30.2	30.2
Max. Overcurrent Protection (A) ²	70/70	70/70	70/70	35	35
Power Supply Conduit Hole Dia. (in)	1.375	1.375	1.375	1.375	1.375
Low-Voltage Conduit Hole Dia. (in)	0.5	0.5	0.5	0.5	0.5
OPERATING WEIGHT (LBS.)					
Operating Weight (lbs)	1244	1244	1244	1244	1244
SHIPPING WEIGHT (LBS.)					
Ship Weight (lbs)	1316	1316	1316	1316	1316

¹ Wire size should be determined in accordance with National Electrical Codes. Extensive wire runs will require larger wire sizes.

² May use fuses or HACR-type circuit breakers of the same size as noted.

Note: Always check the S&R plate for electrical data on the unit being installed.

Model	DSG1504DH00001S	DSG1507DL00001S	DSG1507DM00001S	DSG1507DH00001S
COOLING CAPACITY				
Total, BTU/h	140,000	140,000	140,000	140,000
IEER / EER	14.2/11	14.2/11	14.2/11	14.2/11
SEER2 / EER2	N/A	N/A	N/A	N/A
AHRI Reference #				
HEATING CAPACITY				
Heat Range	HIGH	LOW	MEDIUM	HIGH
No. of Burners	7	5	6	7
High Stage Input / Output (KBTU/H)	240/194.4	130/105.3	180/145.8	240/194.4
Low Stage Input / Output (KBTU/H)	180/145.8	97.5/79	135/109.4	180/145.8
Thermal Efficiency (T.E.)	81%	81%	81%	81%
Annual Fuel Utilization Efficiency (AFUE)	N/A	N/A	N/A	N/A
High Stage Temperature Rise Range (°F)	30-60	25-55	25-55	30-60
Low Stage Temperature Rise Range (°F)	30-60	25-55	25-55	30-60
EVAPORATOR MOTOR / RTPF (ROUND TUBE PLATE FIN)				
Motor Type	Direct Drive	Direct Drive	Direct Drive	Direct Drive
External Static Pressure (ESP)	Standard	Standard	Standard	Standard
Wheel Dia. X Width	15x15	15x15	15x15	15x15
Indoor Nominal CFM	4200	4200	4200	4200
RPM	300-1600	300-1600	300-1600	300-1600
Indoor Horsepower	3.5	3.5	3.5	3.5
Filter Size (in)	20 X 25 X 2 (2) 25 X 25 X 2 (2)	20 X 25 X 2 (2) 25 X 25 X 2 (2)	20 X 25 X 2 (2) 25 X 25 X 2 (2)	20 X 25 X 2 (2) 25 X 25 X 2 (2)
Drain Size (NPT)	3/4	3/4	3/4	3/4
R-32 Refrigerant Charge (oz.)	110/111	110/111	110/111	110/111
Evaporator Coil Face Area (ft²)	16.2	16.2	16.2	16.2
Rows Deep/ Fins per Inch	4 / 16	4 / 16	4 / 16	4 / 16
CONDENSER FAN / MCHX (MICROCHANNEL HEAT EXCHANGER)				
Quantity of Condenser Fan Motors	2	2	2	2
RPM (High/Low stage)	1115	1075	1075	1075
Outdoor Horsepower	1/2	1/2	1/2	1/2
Fan Diameter/ # Fan Blades	22 / 3	22 / 3	22 / 3	22 / 3
Face Area (ft²)	40.8	40.8	40.8	40.8
Rows Deep / Fins per Inch	1 / 23	1 / 23	1 / 23	1 / 23
COMPRESSOR				
Quantity / Type / Stages per Compressor	2/ Scroll / 1	2/ Scroll / 1	2/ Scroll / 1	2/ Scroll / 1
Compressor RLA / LRA	9.0/74.8	7.0/53.9	7.0/53.9	7.0/53.9
ELECTRICAL DATA				
Voltage-Phase-Frequency	460-3-60	575-3-60	575-3-60	575-3-60
Indoor Blower FLA	7.2	5.0	5.0	5.0
Max External Static (In. W.C.)	0.8	0.8	0.8	0.8
Outdoor Fan FLA	1.4	1	1	1
Min. Circuit Ampacity ¹	30.2	22.8	22.8	22.8
Max. Overcurrent Protection (A) ²	35	25	25	25
Power Supply Conduit Hole Dia. (in)	1.375	1.375	1.375	1.375
Low-Voltage Conduit Hole Dia. (in)	0.5	0.5	0.5	0.5
OPERATING WEIGHT (LBS.)				
Operating Weight (lbs)	1244	1244	1244	1244
SHIPPING WEIGHT (LBS.)				
Ship Weight (lbs)	1316	1316	1316	1316

¹ Wire size should be determined in accordance with National Electrical Codes. Extensive wire runs will require larger wire sizes.

² May use fuses or HACR-type circuit breakers of the same size as noted.

Note: Always check the S&R plate for electrical data on the unit being installed.

Model	DSG1503WL00001F	DSG1503WM00001F	DSG1503WH00001F	DSG1504WL00001F	DSG1504WM00001F
COOLING CAPACITY					
Total, BTU/h	140,000	140,000	140,000	140,000	140,000
IEER / EER	14.2/11	14.2/11	14.2/11	14.2/11	14.2/11
SEER2 / EER2	N/A	N/A	N/A	N/A	N/A
AHRI Reference #					
HEATING CAPACITY					
Heat Range	LOW	MEDIUM	HIGH	LOW	MEDIUM
No. of Burners	5	6	7	5	6
High Stage Input / Output (KBTU/H)	130/105.3	180/145.8	240/194.4	130/105.3	180/145.8
Low Stage Input / Output (KBTU/H)	97.5/79	135/109.4	180/145.8	97.5/79	135/109.4
Thermal Efficiency (T.E.)	81%	81%	81%	81%	81%
Annual Fuel Utilization Efficiency (AFUE)	N/A	N/A	N/A	N/A	N/A
High Stage Temperature Rise Range (°F)	25-55	25-55	30-60	25-55	25-55
Low Stage Temperature Rise Range (°F)	25-55	25-55	30-60	25-55	25-55
EVAPORATOR MOTOR / RTPF (ROUND TUBE PLATE FIN)					
Motor Type	Direct Drive	Direct Drive	Direct Drive	Direct Drive	Direct Drive
External Static Pressure (ESP)	High	High	High	High	High
Wheel Dia. X Width	15x15	15x15	15x15	15x15	15x15
Indoor Nominal CFM	4200	4200	4200	4200	4200
RPM	300-1600	300-1600	300-1600	300-1600	300-1600
Indoor Horsepower	5.0	5.0	5.0	5.0	5.0
Filter Size (in)	20 X 25 X 2 (2) 25 X 25 X 2 (2)	20 X 25 X 2 (2) 25 X 25 X 2 (2)	20 X 25 X 2 (2) 25 X 25 X 2 (2)	20 X 25 X 2 (2) 25 X 25 X 2 (2)	20 X 25 X 2 (2) 25 X 25 X 2 (2)
Drain Size (NPT)	3/4	3/4	3/4	3/4	3/4
R-32 Refrigerant Charge (oz.)	110/111	110/111	110/111	110/111	110/111
Evaporator Coil Face Area (ft ²)	16.2	16.2	16.2	16.2	16.2
Rows Deep/ Fins per Inch	4/ 16	4 / 16	4 / 16	4 / 16	4 / 16
CONDENSER FAN / MCHX (MICROCHANNEL HEAT EXCHANGER)					
Quantity of Condenser Fan Motors	2	2	2	2	2
RPM (High/Low stage)	1130	1130	1130	1115	1115
Outdoor Horsepower	1/2	1/2	1/2	1/2	1/2
Fan Diameter/ # Fan Blades	22 / 3	22 / 3	22 / 3	22 / 3	22 / 3
Face Area (ft ²)	40.8	40.8	40.8	40.8	40.8
Rows Deep / Fins per Inch	1 / 23	1 / 23	1 / 23	1 / 23	1 / 23
COMPRESSOR					
Quantity / Type / Stages per Compressor	2/ Scroll / 1	2/ Scroll / 1	2/ Scroll / 1	2/ Scroll / 1	2/ Scroll / 1
Compressor RLA / LRA	19.2/157	19.2/157	19.2/157	9.0/74.8	9.0/74.8
ELECTRICAL DATA					
Voltage-Phase-Frequency	208/230-3-60	208/230-3-60	208/230-3-60	460-3-60	460-3-60
Indoor Blower FLA	14.5	14.5	14.5	10.6	10.6
Max External Static (In. W.C.)	1.8	1.8	1.8	1.8	1.8
Outdoor Fan FLA	2.7	2.7	2.7	1.4	1.4
Min. Circuit Ampacity ¹	63.1/63.1	63.1/63.1	63.1/63.1	33.6	33.6
Max. Overcurrent Protection (A) ²	80/80	80/80	80/80	40	40
Power Supply Conduit Hole Dia. (in)	1.375	1.375	1.375	1.375	1.375
Low-Voltage Conduit Hole Dia. (in)	0.5	0.5	0.5	0.5	0.5
OPERATING WEIGHT (LBS.)					
Operating Weight (lbs)	1244	1244	1244	1244	1244
SHIPPING WEIGHT (LBS.)					
Ship Weight (lbs)	1316	1316	1316	1316	1316

¹ Wire size should be determined in accordance with National Electrical Codes. Extensive wire runs will require larger wire sizes.

² May use fuses or HACR-type circuit breakers of the same size as noted.

Note: Always check the S&R plate for electrical data on the unit being installed.

Model	DSG1504WH00001F	DSG1507WL00001F	DSG1507WM00001F	DSG1507WH00001F
COOLING CAPACITY				
Total, BTU/h	140,000	140,000	140,000	140,000
IEER / EER	14.2/11	14.2/11	14.2/11	14.2/11
SEER2 / EER2	N/A	N/A	N/A	N/A
AHRI Reference #				
HEATING CAPACITY				
Heat Range	HIGH	LOW	MEDIUM	HIGH
No. of Burners	7	5	6	7
High Stage Input / Output (KBTU/H)	240/194.4	130/105.3	180/145.8	240/194.4
Low Stage Input / Output (KBTU/H)	180/145.8	97.5/79	135/109.4	180/145.8
Thermal Efficiency (T.E.)	81%	81%	81%	81%
Annual Fuel Utilization Efficiency (AFUE)	N/A	N/A	N/A	N/A
High Stage Temperature Rise Range (°F)	30-60	25-55	25-55	30-60
Low Stage Temperature Rise Range (°F)	30-60	25-55	25-55	30-60
EVAPORATOR MOTOR / RTPF (ROUND TUBE PLATE FIN)				
Motor Type	Direct Drive	Direct Drive	Direct Drive	Direct Drive
External Static Pressure (ESP)	High	High	High	High
Wheel Dia. X Width	15x15	15x15	15x15	15x15
Indoor Nominal CFM	4200	4200	4200	4200
RPM	300-1600	300-1600	300-1600	300-1600
Indoor Horsepower	5.0	5.0	5.0	5.0
Filter Size (in)	20 X 25 X 2 (2) 25 X 25 X 2 (2)	20 X 25 X 2 (2) 25 X 25 X 2 (2)	20 X 25 X 2 (2) 25 X 25 X 2 (2)	20 X 25 X 2 (2) 25 X 25 X 2 (2)
Drain Size (NPT)	3/4	3/4	3/4	3/4
R-32 Refrigerant Charge (oz.)	110/111	110/111	110/111	110/111
Evaporator Coil Face Area (ft²)	16.2	16.2	16.2	16.2
Rows Deep/ Fins per Inch	4 / 16	4 / 16	4 / 16	4 / 16
CONDENSER FAN / MCHX (MICROCHANNEL HEAT EXCHANGER)				
Quantity of Condenser Fan Motors	2	2	2	2
RPM (High/Low stage)	1115	1075	1075	1075
Outdoor Horsepower	1/2	1/2	1/2	1/2
Fan Diameter/ # Fan Blades	22 / 3	22 / 3	22 / 3	22 / 3
Face Area (ft²)	40.8	40.8	40.8	40.8
Rows Deep / Fins per Inch	1 / 23	1 / 23	1 / 23	1 / 23
COMPRESSOR				
Quantity / Type / Stages per Compressor	2/ Scroll / 1	2/ Scroll / 1	2/ Scroll / 1	2/ Scroll / 1
Compressor RLA / LRA	9.0/74.8	7.0/53.9	7.0/53.9	7.0/53.9
ELECTRICAL DATA				
Voltage-Phase-Frequency	460-3-60	575-3-60	575-3-60	575-3-60
Indoor Blower FLA	10.6	7.2	7.2	7.2
Max External Static (In. W.C.)	1.8	1.8	1.8	1.8
Outdoor Fan FLA	1.4	1	1	1
Min. Circuit Ampacity ¹	33.6	25	25	25
Max. Overcurrent Protection (A) ²	40	30	30	30
Power Supply Conduit Hole Dia. (in)	1.375	1.375	1.375	1.375
Low-Voltage Conduit Hole Dia. (in)	0.5	0.5	0.5	0.5
OPERATING WEIGHT (LBS.)				
Operating Weight (lbs)	1244	1244	1244	1244
SHIPPING WEIGHT (LBS.)				
Ship Weight (lbs)	1316	1316	1316	1316

¹ Wire size should be determined in accordance with National Electrical Codes. Extensive wire runs will require larger wire sizes.

² May use fuses or HACR-type circuit breakers of the same size as noted.

Note: Always check the S&R plate for electrical data on the unit being installed.

Coil Dimensions

Tons	Indoor			Outdoor		
	Fin height in.	Fin length in.	Area (Ft ²)	Fin height in.	Fin length in.	Area (Ft ²)
7.5	42.0	46.0	13.4	45.6	46.0	29.1
8.5	42.0	46.0	13.4	45.6	45.9	29.1
10	45.0	51.8	16.2	45.6	45.9	29.1
12.5	45.0	51.8	16.2	48.6	60.4	40.8

AHRI Ratings

Gas / Electric			
Model	Capacity	EER	IEER
DSG0903D	90,000	12.0	16
DSG0904D	90,000	12.0	16
DSG0907D	90,000	12.0	16
DSG1023D	97,000	11.4	15.5
DSG1024D	97,000	11.4	15.5
DSG1027D	97,000	11.4	15.5
DSG1203D	116,000	11.4	15.2
DSG1204D	116,000	11.4	15.2
DSG1207D	116,000	11.4	15.2
DSG1503D	140,000	11.4	15.2
DSG1504D	140,000	11.4	15.2
DSG1507D	140,000	11.4	15.2

Sound Data

STATIC PRESSURE	7.5 TON SOUND (DB) AT 60 HZ										
	Indoor CFM	Component	A-Weighted	63	125	250	500	1000	2000	4000	8000
0.8	3,000	Discharge	68.7	92.1	76.0	63.9	62.6	62.1	57.2	56.3	46.4
		Inlet	63.8	87.9	72.4	64.4	58.2	52.2	46.9	47.1	46.3
Discharge		78.3	98.6	87.0	72.2	72.7	72.8	68.5	66.7	60.8	
Inlet		70.2	90.7	80.7	69.6	64.6	61.7	56.6	56.5	53	
2.0	3,000	Discharge	82.4	97.6	88.4	85	77.1	77.1	72.5	71.7	67.3
		Inlet	74.8	92.6	84.0	78.2	69.9	66.5	61.8	62.1	58.4
N/A	N/A	Outdoor	82.6	89.2	86.0	83.1	79.2	77.3	74.2	69.6	67.7

STATIC PRESSURE	8.5 TON SOUND (DB) AT 60 HZ										
	Indoor CFM	Component	A-Weighted	63	125	250	500	1000	2000	4000	8000
0.8	3,400	Discharge	71.3	93.5	79.9	65.3	66.0	65.1	60.8	58.1	49.9
		Inlet	65.3	87.0	75.8	66.8	59.7	54.6	49.8	49.2	47.0
Discharge		81.5	99.6	88.8	78.8	76.4	76.6	71.5	70.3	64.9	
Inlet		73.1	91.4	82.8	74.6	67.4	66.2	60.0	60.5	56.7	
2.0	3,400	Discharge	80.8	99.7	89.4	76.1	75.2	75.5	71.4	69.7	65.3
		Inlet	72.7	92.5	82.6	73.6	66.9	64.3	59.5	59.5	56.0
N/A	N/A	Outdoor	82.6	89.2	86.0	83.1	79.2	77.3	74.2	69.6	67.7

STATIC PRESSURE	10 TON SOUND (DB) AT 60 HZ										
	Indoor CFM	Component	A-Weighted	63	125	250	500	1000	2000	4000	8000
0.8	4,000	Discharge	74.5	92.3	82.2	71.0	70.8	69.0	64.1	65.6	55.6
		Inlet	67.2	88.8	76.6	66.8	62.2	58.5	54.7	52.4	47.4
Discharge		76.8	95.8	85.3	72.2	71.7	71.2	67.3	65.2	59.8	
Inlet		69.2	89.5	79.3	68.8	63.9	60.6	57.1	55.5	50.5	
2.0	4,000	Discharge	77.1	96.2	85.3	72.5	72.0	71.5	67.6	65.3	59.9
		Inlet	71.0	91.7	81.2	70.8	65.2	62.0	58.8	57.4	53.1
N/A	N/A	Outdoor	82.6	89.2	86.0	83.1	79.2	77.3	74.2	69.6	67.7

STATIC PRESSURE	12.5 TON SOUND (DB) AT 60 HZ										
	Indoor CFM	Component	A-Weighted	63	125	250	500	1000	2000	4000	8000
0.8	5,000	Discharge	78.5	92.6	82.0	73.2	74.2	74.5	69.4	68.6	63.2
		Inlet	70.1	92.3	78.8	68.7	64.0	62.2	57.7	57.3	52.2
Discharge		79.5	93.1	84.7	77.1	74.9	75.4	69.9	68.9	63.8	
Inlet		72.0	91.9	82.6	72.5	66.4	63.8	59.5	58.8	53.8	
2.0	5,000	Discharge	82.4	100.4	90.1	78.2	77.3	77.2	72.9	71.1	66.7
		Inlet	73.4	93.2	84.0	73.1	67.9	65.0	61.4	60.7	56.0
N/A	N/A	Outdoor	86.8	95.4	85.3	86.8	83.3	81.7	79.8	72.2	66.9

¹ Outdoor sound data is measured in accordance with AHRI standard 270

² Discharge and Inlet sound data was measured in accordance with AHRI standard 260.

³ Measurements are expressed in terms of sound power. Do not compare these values to sound pressure values because sound pressure depends on specific environment factors which normally do not match individual applications. Sound power values are independent of the environment and therefore more accurate.

⁴ A-weighted sound ratings filter out high and very low frequencies, to better approximate the response of "average" human ear. A-weighted measurements for Daikin units are taken in accordance with AHRI standards 260 and 270.

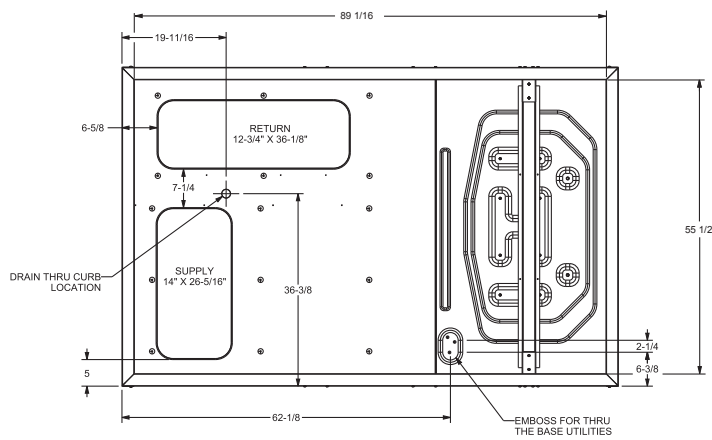
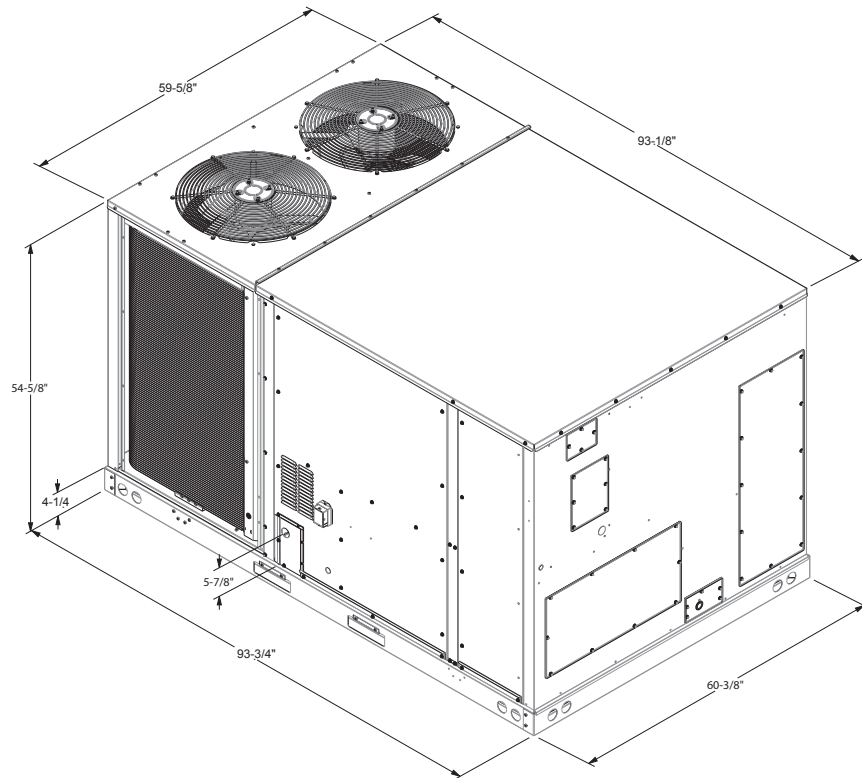

Model Size	DIM "A"
DSG 090	8.96
DSG 102	8.96
DSG 120	6.46
DSG 150	6.46

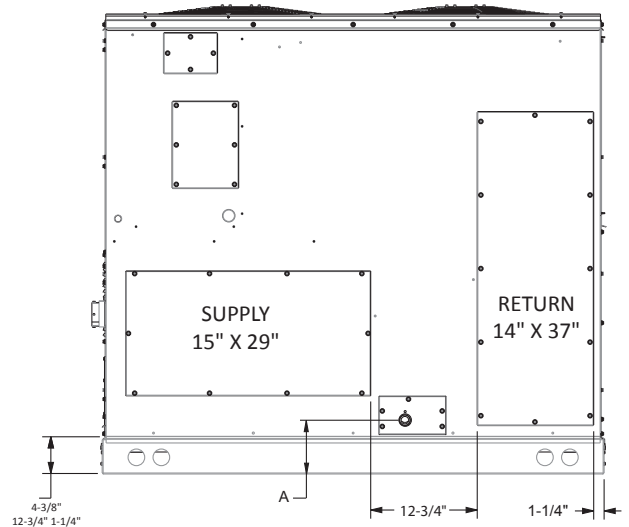

HORIZONTAL DISCHARGE

IDB		Outdoor Ambient Temperature																																																																																																																																																																																																																																																																																																																																																																																																																																																																																																																																																																																																																																																																																																																																																																																																																																																																																																																																																																																																																																																																																																																																																																																																																																																																																						
		65								75								85								95								105								115																																																																																																																																																																																																																																																																																																																																																																																																																																																																																																																																																																																																																																																																																																																																																																																																																																																																																																																																																																																																																																																																																																																																																																																																																																														
		IDB	Airflow	59	63	67	71	75	79	83	87	91	95	99	103	107	111	115	119	123	127	131	135	139	143	147	151	155	159	163	167	171	175	179	183	187	191	195	199	203	207	211	215	219	223	227	231	235	239	243	247	251	255	259	263	267	271	275	279	283	287	291	295	299	303	307	311	315	319	323	327	331	335	339	343	347	351	355	359	363	367	371	375	379	383	387	391	395	399	403	407	411	415	419	423	427	431	435	439	443	447	451	455	459	463	467	471	475	479	483	487	491	495	499	503	507	511	515	519	523	527	531	535	539	543	547	551	555	559	563	567	571	575	579	583	587	591	595	599	603	607	611	615	619	623	627	631	635	639	643	647	651	655	659	663	667	671	675	679	683	687	691	695	699	703	707	711	715	719	723	727	731	735	739	743	747	751	755	759	763	767	771	775	779	783	787	791	795	799	803	807	811	815	819	823	827	831	835	839	843	847	851	855	859	863	867	871	875	879	883	887	891	895	899	903	907	911	915	919	923	927	931	935	939	943	947	951	955	959	963	967	971	975	979	983	987	991	995	999	1003	1007	1011	1015	1019	1023	1027	1031	1035	1039	1043	1047	1051	1055	1059	1063	1067	1071	1075	1079	1083	1087	1091	1095	1099	1103	1107	1111	1115	1119	1123	1127	1131	1135	1139	1143	1147	1151	1155	1159	1163	1167	1171	1175	1179	1183	1187	1191	1195	1199	1203	1207	1211	1215	1219	1223	1227	1231	1235	1239	1243	1247	1251	1255	1259	1263	1267	1271	1275	1279	1283	1287	1291	1295	1299	1303	1307	1311	1315	1319	1323	1327	1331	1335	1339	1343	1347	1351	1355	1359	1363	1367	1371	1375	1379	1383	1387	1391	1395	1399	1403	1407	1411	1415	1419	1423	1427	1431	1435	1439	1443	1447	1451	1455	1459	1463	1467	1471	1475	1479	1483	1487	1491	1495	1499	1503	1507	1511	1515	1519	1523	1527	1531	1535	1539	1543	1547	1551	1555	1559	1563	1567	1571	1575	1579	1583	1587	1591	1595	1599	1603	1607	1611	1615	1619	1623	1627	1631	1635	1639	1643	1647	1651	1655	1659	1663	1667	1671	1675	1679	1683	1687	1691	1695	1699	1703	1707	1711	1715	1719	1723	1727	1731	1735	1739	1743	1747	1751	1755	1759	1763	1767	1771	1775	1779	1783	1787	1791	1795	1799	1803	1807	1811	1815	1819	1823	1827	1831	1835	1839	1843	1847	1851	1855	1859	1863	1867	1871	1875	1879	1883	1887	1891	1895	1899	1903	1907	1911	1915	1919	1923	1927	1931	1935	1939	1943	1947	1951	1955	1959	1963	1967	1971	1975	1979	1983	1987	1991	1995	1999	2003	2007	2011	2015	2019	2023	2027	2031	2035	2039	2043	2047	2051	2055	2059	2063	2067	2071	2075	2079	2083	2087	2091	2095	2099	2103	2107	2111	2115	2119	2123	2127	2131	2135	2139	2143	2147	2151	2155	2159	2163	2167	2171	2175	2179	2183	2187	2191	2195	2199	2203	2207	2211	2215	2219	2223	2227	2231	2235	2239	2243	2247	2251	2255	2259	2263	2267	2271	2275	2279	2283	2287	2291	2295	2299	2303	2307	2311	2315	2319	2323	2327	2331	2335	2339	2343	2347	2351	2355	2359	2363	2367	2371	2375	2379	2383	2387	2391	2395	2399	2403	2407	2411	2415	2419	2423	2427	2431	2435	2439	2443	2447	2451	2455	2459	2463	2467	2471	2475	2479	2483	2487	2491	2495	2499	2503	2507	2511	2515	2519	2523	2527	2531	2535	2539	2543	2547	2551	2555	2559	2563	2567	2571	2575	2579	2583	2587	2591	2595	2599	2603	2607	2611	2615	2619	2623	2627	2631	2635	2639	2643	2647	2651	2655	2659	2663	2667	2671	2675	2679	2683	2687	2691	2695	2699	2703	2707	2711	2715	2719	2723	2727	2731	2735	2739	2743	2747	2751	2755	2759	2763	2767	2771	2775	2779	2783	2787	2791	2795	2799	2803	2807	2811	2815	2819	2823	2827	2831	2835	2839	2843	2847	2851	2855	2859	2863	2867	2871	2875	2879	2883	2887	2891	2895	2899	2903	2907	2911	2915	2919	2923	2927	2931	2935	2939	2943	2947	2951	2955	2959	2963	2967	2971	2975	2979	2983	2987	2991	2995	2999	3003	3007	3011	3015	3019	3023	3027	3031	3035	3039	3043	3047	3051	3055	3059	3063	3067	3071	3075	3079	3083	3087	3091	3095	3099	3103	3107	3111	3115	3119	3123	3127	3131	3135	3139	3143	3147	3151	3155	3159	3163	3167	3171	3175	3179	3183	3187	3191	3195	3199	3203	3207	3211	3215	3219	3223	3227	3231	3235	3239	3243	3247	3251	3255	3259	3263	3267	3271	3275	3279	3283	3287	3291	3295	3299	3303	3307	3311	3315	3319	3323	3327	3331	3335	3339	3343	3347	3351	3355	3359	3363	3367	3371	3375	3379	3383	3387	3391	3395	3399	3403	3407	3411	3415	3419	3423	3427	3431	3435	3439	3443	3447	3451	3455	3459	3463	3467	3471	3475	3479	3483	3487	3491	3495	3499	3503	3507	3511	3515	3519	3523	3527	3531	3535	3539	3543	3547	3551	3555	3559	3563	3567	3571	3575	3579	3583	3587	3591	3595	3599	3603	3607	3611	3615	3619	3623	3627	3631	3635	3639	3643	3647	3651	3655	3659	3663	3667	3671	3675	3679	3683	3687	3691	3695	3699	3703	3707	3711	3715	3719	3723	3727	3731	3735	3739	3743	3747	3751	3755	3759	3763	3767	3771	3775	3779	3783	3787	3791	3795	3799	3803	3807	3811	3815	3819	3823	3827	3831	3835	3839	3843	3847	3851	3855	3859	3863	3867	3871	3875	3879	3883	3887	3891	3895	3899	3903	3907	3911	3915	3919	3923	3927	3931	3935	3939	3943	3947	3951	3955	3959	3963	3967	3971	3975	3979	3983	3987	3991	3995	3999	4003	4007	4011	4015	4019	4023	4027	4031	4035	4039	4043	4047	4051	4055	4059	4063	4067	4071	4075	4079	4083	4087	4091	4095	4099	4103	4107	4111	4115	4119	4123	4127	4131	4135	4139	4143	4147	4151	4155	4159	4163	4167	4171	4175	4179	4183	4187	4191	4195	4199	4203	4207	4211	4215	4219	4223	4227	4231	4235	4239	4243	4247	4251	4255	4259	4263	4267	4271	4275	4279	4283	4287	4291	4295	4299	4303	4307	4311	4315	4319	4323	4327	4331	4335	4339	4343	4347	4351	4355	4359	4363	4367	4371	4375	4379	4383	4387	4391	4395	4399	4403	4407	4411	4415	4419	4423	4427	4431	4435	4439	4443	4447	4451	4455	4459	4463	4467	4471	4475	4479	4483	4487	4491	4495	4499	4503	4507	4511	4515	4519	4523	4527	4531	4535	4539	4543	4547	4551	4555	4559	4563	4567	4571	4575	4579	4583	4587	4591	4595	4599	4603	4607	4611	4615	4619	4623	4627	4631	4635	4639	4643	4647	4651	4655	4659	4663	4667	4671	4675	4679	4683	4687	4691	4695	4699	4703	4707	4711	4715	4719	4723	4727	4731	4735	4739	4743	4747	4751	4755	4759	4763	4767	4771	4775	4779	4783	4787	4791	4795	4799	4803	4807	4811	4815	4819	4823	4827	4831	4835	4839	4843	4847	4851	4855	4859	4863	4867	4871	4875	4879	4883	4887	4891	4895	4899	4903	4907	4911	4915	4919	4923	4927	4931	4935	4939	4943	4947	4951	4955	4959	4963	4967	4971	4975	4979	4983	4987	4991	4995	4999	5003

		Outdoor Ambient Temperature												105												115																							
IDB	Airflow	Entering Indoor Wet Bulb Temperature												95												105												115											
		75				85				95				105				115				105				115																							
		59	63	67	71	59	63	67	71	59	63	67	71	59	63	67	71	59	63	67	71	59	63	67	71	59	63	67	71	59	63	67	71																
80	Capacity	92,092	93,386	96,121	100,299	91,273	92,566	95,301	99,480	88,882	90,175	92,910	97,089	84,768	86,061	88,797	92,975	79,741	81,034	83,769	87,947	75,151	76,444	79,180	83,358	75,151	76,444	79,180	83,358	75,151	76,444	79,180	83,358																
	S/T	1.00	0.77	0.64	0.50	1.00	0.78	0.65	0.51	1.00	0.78	0.65	0.51	1.00	0.69	0.57	0.45	1.00	0.71	0.59	0.47	1.00	0.63	0.51	0.39	1.00	0.63	0.51	0.39	1.00	0.63	0.51	0.39																
	Evap dT	26.45	24.71	21.47	18.11	26.40	24.66	21.42	18.06	26.64	24.91	21.66	18.30	26.38	24.64	21.40	18.04	26.15	24.41	21.17	17.81	27.24	25.50	22.26	18.90	27.24	25.50	22.26	18.90	27.24	25.50	22.26	18.90																
	Pr Suc	133.56	135.20	138.58	144.25	141.65	143.29	146.67	152.33	148.73	150.37	153.76	159.42	154.72	156.36	159.75	165.41	160.60	162.24	165.62	171.28	167.96	169.60	172.98	178.64	167.96	169.60	172.98	178.64	167.96	169.60	172.98	178.64																
	Pr Dis	260.72	261.85	263.67	268.21	301.75	302.88	304.70	309.24	344.73	345.86	347.69	352.22	391.01	392.14	393.97	398.50	440.92	442.04	443.87	448.41	494.17	495.30	497.13	501.66	494.17	495.30	497.13	501.66	494.17	495.30	497.13	501.66																
	ODamps	21.25	21.23	21.18	21.40	24.17	24.15	24.10	24.32	27.43	27.41	27.36	27.58	30.96	30.93	30.88	31.11	34.90	34.87	34.82	35.05	39.52	39.50	39.45	39.67	39.52	39.50	39.45	39.67	39.52	39.50	39.45	39.67																
	TotalPower	5,419	5,414	5,404	5,452	6,057	6,052	6,042	6,090	6,770	6,765	6,754	6,803	7,540	7,535	7,524	7,573	8,402	8,397	8,386	8,434	9,412	9,407	9,396	9,445	9,412	9,407	9,396	9,445	9,412	9,407	9,396	9,445																
	Capacity	93,295	94,588	97,324	101,502	92,476	93,769	96,504	100,682	90,085	91,378	94,113	98,291	85,971	87,264	89,999	94,178	80,943	82,237	84,972	89,150	76,354	77,647	80,382	84,561	76,354	77,647	80,382	84,561	76,354	77,647	80,382	84,561																
	S/T	1.00	0.83	0.70	0.56	1.00	0.84	0.71	0.57	1.00	0.80	0.67	0.53	1.00	0.75	0.61	0.47	1.00	0.70	0.56	0.42	1.00	0.63	0.50	0.36	1.00	0.63	0.50	0.36	1.00	0.63	0.50	0.36																
	Evap dT	25.40	23.66	20.42	17.06	25.35	23.61	20.37	17.01	25.59	23.86	20.61	17.25	25.33	23.59	20.35	17.00	25.10	23.36	20.12	16.76	26.19	24.45	21.21	17.85	26.19	24.45	21.21	17.85	26.19	24.45	21.21	17.85																
Pr Suc	135.51	137.15	140.54	146.20	143.60	145.24	148.63	154.29	150.68	152.33	155.71	161.37	156.67	158.32	161.70	167.36	162.55	164.19	167.58	173.24	169.91	171.55	174.94	180.60	169.91	171.55	174.94	180.60	169.91	171.55	174.94	180.60																	
Pr Dis	262.93	264.05	265.88	270.42	303.96	305.08	306.91	311.44	346.94	348.07	349.90	354.43	393.22	394.35	396.18	400.71	443.13	444.25	446.08	450.61	496.38	497.51	499.34	503.87	496.38	497.51	499.34	503.87	496.38	497.51	499.34	503.87																	
ODamps	21.40	21.38	21.33	21.55	24.32	24.30	24.25	24.47	27.58	27.56	27.51	27.73	31.11	31.09	31.04	31.26	35.05	35.03	34.98	35.20	39.67	39.65	39.60	39.82	39.67	39.65	39.60	39.82	39.67	39.65	39.60	39.82																	
TotalPower	5,453	5,448	5,437	5,485	6,091	6,086	6,075	6,123	6,803	6,798	6,787	6,836	7,573	7,568	7,558	7,606	8,435	8,430	8,419	8,467	9,445	9,440	9,429	9,478	9,445	9,440	9,429	9,478	9,445	9,440	9,429	9,478																	
Capacity	94,740	96,033	98,768	102,947	93,920	95,213	97,949	102,127	91,529	92,822	95,558	99,736	87,416	88,709	91,444	95,622	82,388	83,681	86,417	90,595	77,798	79,092	81,827	86,005	77,798	79,092	81,827	86,005	77,798	79,092	81,827	86,005																	
S/T	1.00	0.87	0.73	0.59	1.00	0.88	0.74	0.60	1.00	0.84	0.70	0.56	1.00	0.78	0.64	0.50	1.00	0.72	0.58	0.44	1.00	0.65	0.51	0.37	1.00	0.65	0.51	0.37	1.00	0.65	0.51	0.37																	
Evap dT	24.51	22.78	19.53	16.17	24.47	22.73	19.49	16.13	24.71	22.97	19.73	16.37	24.45	22.71	19.47	16.11	24.22	22.48	19.24	15.88	25.30	23.57	20.32	16.96	25.30	23.57	20.32	16.96	25.30	23.57	20.32	16.96																	
Pr Suc	137.68	139.32	142.70	148.37	145.77	147.41	150.79	156.45	152.85	154.49	157.88	163.54	158.84	160.48	163.87	169.53	164.72	166.36	169.74	175.41	172.08	173.72	177.10	182.77	172.08	173.72	177.10	182.77	172.08	173.72	177.10	182.77																	
Pr Dis	265.07	266.20	268.03	272.56	306.10	307.23	309.06	313.59	349.08	350.21	352.04	356.57	395.37	396.50	398.32	402.86	445.27	446.40	448.23	452.76	498.52	499.65	501.48	506.01	498.52	499.65	501.48	506.01	498.52	499.65	501.48	506.01																	
ODamps	21.53	21.51	21.46	21.68	24.45	24.43	24.38	24.60	27.71	27.68	27.63	27.86	31.23	31.21	31.16	31.39	35.18	35.15	35.10	35.33	39.80	39.78	39.73	39.95	39.80	39.78	39.73	39.95	39.80	39.78	39.73	39.95																	
TotalPower	5,480	5,475	5,464	5,513	6,118	6,113	6,102	6,151	6,831	6,826	6,815	6,863	7,601	7,596	7,585	7,634	8,462	8,457	8,446	8,495	9,473	9,468	9,457	9,506	9,473	9,468	9,457	9,506	9,473	9,468	9,457	9,506																	
85	Capacity	93,635	94,929	97,664	101,842	92,816	94,109	96,844	101,022	90,425	91,718	94,453	98,631	86,311	87,604	90,340	94,518	81,284	82,577	85,312	89,490	76,694	77,987	80,722	84,901	76,694	77,987	80,722	84,901	76,694	77,987	80,722	84,901																
	S/T	1.00	1.00	0.74	0.60	1.00	1.00	0.75	0.61	1.00	1.00	0.77	0.63	1.00	1.00	0.79	0.65	1.00	1.00	0.77	0.63	1.00	1.00	0.77	0.63	1.00	1.00	0.77	0.63	1.00	1.00	0.77	0.63																
	Evap dT	29.86	28.12	24.88	21.52	29.81	28.07	24.83	21.47	30.05	28.32	25.07	21.71	29.79	28.05	24.81	21.45	29.56	27.82	24.58	21.22	30.65	28.91	25.67	22.31	30.65	28.91	25.67	22.31	30.65	28.91	25.67	22.31																
	Pr Suc	135.55	137.19	140.58	146.24	143.64	145.28	148.67	154.33	150.72	152.36	155.75	161.41	156.71	158.35	161.74	167.40	162.59	164.23	167.62	173.28	169.95	171.59	174.98	180.64	169.95	171.59	174.98	180.64	169.95	171.59	174.98	180.64																
	Pr Dis	261.94	263.07	264.90	269.43	302.97	304.10	305.93	310.46	345.95	347.08	348.91	353.44	392.24	393.37	395.19	399.73	442.14	443.27	445.10	449.63	495.39	496.52	498.35	502.88	495.39	496.52	498.35	502.88	495.39	496.52	498.35	502.88																
	ODamps	21.31	21.28	21.23	21.46	24.23	24.20	24.15	24.38	27.49	27.46	27.41	27.64	31.01	30.99	30.94	31.16	34.95	34.93	34.88	35.10	39.58	39.55	39.50	39.73	39.58	39.55	39.50	39.73	39.58	39.55	39.50	39.73																
	TotalPower	5,432	5,427	5,416	5,465	6,070	6,065	6,054	6,103	6,782	6,777	6,766	6,815	7,553	7,548	7,537	7,585	8,414	8,409	8,398	8,447	9,424	9,419	9,408	9,457	9,424	9,419	9,408	9,457	9,424	9,419	9,408	9,457																
	Capacity	94,838	96,131	98,867	103,045	94,018	95,312	98,047	102,225	91,627	92,921	95,656	99,834	87,514	88,807	91,542	95,720	82,486	83,780	86,515	90,693	77,897	79,190	81,925	86,103	77,897	79,190	81,925	86,103	77,897	79,190	81,925	86,103																
	S/T	1.00	1.00	0.80	0.66	1.00	1.00	0.81	0.67	1.00	1.00	0.83	0.69	1.00	1.00	0.81	0.67	1.00	1.00	0.81	0.67	1.00	1.00	0.81	0.67	1.00	1.00	0.81	0.67	1.00	1.00	0.81	0.67																
	Evap dT	28.81	27.07	23.83	20.47	28.76	27.02	23.78	20.42	29.00	27.27	24.02	20.66	28.74	27.00	23.76	20.40	28.51	26.77	23.53	20.17	29.60	27.86	24.62	21.26	29.60	27.86	24.62	21.26	29.60	27.86	24.62	21.26																
Pr Suc	137.51	139.15	142.53	148.19	145.59	147.24	150.62	156.28	152.68	154.32	157.70	163.37	158.67	160.31	163.69	169.36	164.54	166.19	169.57	175.23	171.90	173.55	176.93	182.59	171.90	173.55	176.93	182.59	171.90	173.55	176.93	182.59																	
Pr Dis	264.15	265.28	267.11	271.64	305.18	306.31	308.14	312.67	348.16	349.29	351.12	355.65	394.45	395.57	397.40	401.94	444.35	445.48	447.31	451.84	497.60	498.73	500.56	505.09	497.60	498.73	500.56	505.09	497.60	498.73	500.56	505.09																	
ODamps	21.46	21.43	21.38	21.61	24.38	24.35	24.30	24.53	27.64	27.61																																							

IDB	Airflow	ID WB	Outdoor Ambient Temperature																							
			65				75				85				95				105				115			
			59	63	67	71	59	63	67	71	59	63	67	71	59	63	67	71	59	63	67	71	59	63	67	71
70	2975	Capacity	99,225	100,619	103,567	98,342	99,736	102,684	95,765	97,159	100,107	91,331	92,725	95,673	85,913	87,307	90,255	80,966	82,360	85,308						
		S/T	0.62	0.54	0.41	0.62	0.55	0.42	1.00	0.57	0.44	1.00	0.59	0.46	1.00	0.62	0.48	1.00	1.00	0.53						
		Evap dT	18.30	16.56	13.32	18.25	16.51	13.27	18.49	16.76	13.51	18.23	16.49	13.25	18.00	16.26	13.02	19.09	17.35	14.11						
		Pr Suc	129.58	131.17	134.45	137.41	139.00	142.28	144.27	145.86	149.14	150.07	151.66	154.94	155.77	157.36	160.64	162.89	164.49	167.76						
		Pr Dis	265.90	267.05	268.91	307.70	308.85	310.71	351.49	352.64	354.51	398.65	399.80	401.66	449.49	450.64	452.50	503.75	504.89	506.76						
		ODamps	24.38	24.36	24.30	27.55	27.53	27.47	31.09	31.06	31.01	34.92	34.89	34.84	39.19	39.17	39.11	44.21	44.19	44.13						
		TotalPower	6,269	6,263	6,251	6,961	6,955	6,944	7,734	7,728	7,716	8,570	8,565	8,553	9,505	9,499	9,487	10,601	10,595	10,584						
		Capacity	99,983	101,377	104,325	99,099	100,493	103,441	96,522	97,916	100,864	92,089	93,483	96,431	86,670	88,064	91,012	81,724	83,118	86,066						
		S/T	0.65	0.57	0.44	0.65	0.58	0.45	1.00	0.60	0.47	1.00	0.62	0.49	1.00	0.64	0.51	1.00	1.00	0.56						
		Evap dT	17.73	16.00	12.75	17.68	15.95	12.70	17.93	16.19	12.95	17.67	15.93	12.69	17.44	15.70	12.45	18.52	16.79	13.54						
Pr Suc	130.66	132.25	135.53	138.49	140.08	143.36	145.36	146.95	150.22	151.16	152.75	156.03	156.85	158.44	161.72	163.98	165.57	168.85								
Pr Dis	267.15	268.30	270.16	308.95	310.10	311.96	352.74	353.89	355.75	399.90	401.05	402.91	450.74	451.89	453.75	504.99	506.14	508.01								
ODamps	24.47	24.45	24.39	27.64	27.62	27.56	31.18	31.15	31.10	35.00	34.98	34.93	39.28	39.26	39.20	44.30	44.27	44.22								
TotalPower	6,288	6,282	6,271	6,980	6,975	6,963	7,753	7,748	7,736	8,589	8,584	8,572	9,524	9,518	9,507	10,620	10,615	10,603								
Capacity	102,550	103,944	106,892	101,667	103,061	106,009	99,090	100,484	103,432	94,656	96,050	98,998	89,238	90,632	93,580	84,291	85,685	88,633								
S/T	0.69	0.62	0.48	0.70	0.62	0.49	1.00	0.65	0.51	1.00	0.66	0.53	1.00	0.69	0.55	1.00	1.00	0.60								
Evap dT	16.40	14.66	11.42	16.35	14.61	11.37	16.60	14.86	11.62	16.33	14.60	11.35	16.10	14.36	11.12	17.19	15.45	12.21								
Pr Suc	134.06	135.65	138.93	141.89	143.48	146.76	148.75	150.35	153.62	154.56	156.15	159.43	160.25	161.84	165.12	167.38	168.97	172.25								
Pr Dis	270.58	271.73	273.59	312.38	313.53	315.39	356.17	357.32	359.18	403.33	404.48	406.34	454.17	455.32	457.18	508.42	509.57	511.44								
ODamps	24.68	24.65	24.60	27.85	27.82	27.77	31.38	31.36	31.31	35.21	35.19	35.13	39.49	39.46	39.41	44.51	44.48	44.43								
TotalPower	6,333	6,328	6,316	7,026	7,020	7,008	7,798	7,793	7,781	8,635	8,629	8,617	9,569	9,564	9,552	10,666	10,660	10,648								

IDB	Airflow	ID WB	Outdoor Ambient Temperature																							
			65				75				85				95				105				115			
			59	63	67	71	59	63	67	71	59	63	67	71	59	63	67	71	59	63	67	71	59	63	67	71
75	2975	Capacity	99,225	100,619	103,567	98,342	99,736	102,684	95,765	97,159	100,107	91,331	92,725	95,673	85,913	87,307	90,255	80,966	82,360	85,308						
		S/T	0.62	0.54	0.41	0.62	0.55	0.42	1.00	0.57	0.44	1.00	0.59	0.46	1.00	0.62	0.48	1.00	1.00	0.53						
		Evap dT	18.30	16.56	13.32	18.25	16.51	13.27	18.49	16.76	13.51	18.23	16.49	13.25	18.00	16.26	13.02	19.09	17.35	14.11						
		Pr Suc	129.58	131.17	134.45	137.41	139.00	142.28	144.27	145.86	149.14	150.07	151.66	154.94	155.77	157.36	160.64	162.89	164.49	167.76						
		Pr Dis	265.90	267.05	268.91	307.70	308.85	310.71	351.49	352.64	354.51	398.65	399.80	401.66	449.49	450.64	452.50	503.75	504.89	506.76						
		ODamps	24.38	24.36	24.30	27.55	27.53	27.47	31.09	31.06	31.01	34.92	34.89	34.84	39.19	39.17	39.11	44.21	44.19	44.13						
		TotalPower	6,269	6,263	6,251	6,961	6,955	6,944	7,734	7,728	7,716	8,570	8,565	8,553	9,505	9,499	9,487	10,601	10,595	10,584						
		Capacity	100,040	101,434	104,382	100,040	101,434	104,382	99,157	100,551	103,499	100,002	99,157	100,551	103,499	100,002	99,157	100,551	103,499	100,002						
		S/T	0.77	0.70	0.57	0.43	0.71	0.64	0.50	1.00	0.73	0.60	0.46	1.00	0.75	0.62	0.48	1.00	1.00	0.69	0.55					
		Evap dT	21.55	19.81	16.57	13.21	21.50	19.77	16.52	21.75	20.01	16.77	13.41	21.49	19.75	16.51	13.15	21.25	19.52	16.27	12.91					
Pr Suc	130.69	132.28	135.56	141.04	138.52	140.12	143.39	145.39	146.98	150.26	155.74	151.19	152.78	156.06	161.54	156.88	158.47	161.75	167.23							
Pr Dis	267.38	268.53	270.40	275.01	309.18	310.33	312.20	352.98	354.13	355.99	360.61	400.13	401.28	403.14	407.76	450.97	452.12	453.98	458.60							
ODamps	24.45	24.43	24.37	24.61	27.62	27.59	27.54	31.16	31.13	31.08	31.32	34.98	34.96	34.91	35.15	39.26	39.24	39.18	39.42							
TotalPower	6,283	6,278	6,266	6,319	6,976	6,970	6,958	7,749	7,743	7,731	7,784	8,585	8,579	8,568	8,621	9,519	9,514	9,502	9,555							
Capacity	102,608	104,001	106,950	101,453	102,846	105,794	99,147	100,541	103,489	100,991	99,146	100,540	103,488	100,991	99,146	100,540	103,488	100,991	99,146							
S/T	1.00	0.74	0.61	0.47	1.00	0.75	0.61	1.00	0.77	0.64	0.50	1.00	0.76	0.62	0.52	1.00	1.00	0.68	0.54							
Evap dT	20.22	18.48	15.24	11.88	20.17	18.43	15.19	20.41	18.68	15.43	12.07	20.15	18.42	15.17	11.81	19.92	18.18	14.94	11.58							
Pr Suc	134.09	135.68	138.96	144.44	141.92	143.51	146.79	148.79	150.38	153.65	159.14	154.59	156.18	159.46	164.94	160.28	161.87	165.15	170.63							
Pr Dis	270.81	271.96	273.83	278.44	312.61	313.76	315.63	356.41	357.56	359.42	364.04	403.56	404.71	406.57	411.19	454.40	455.55	457.41	462.03							
ODamps	24.66	24.63	24.58	24.82	27.83	27.80	27.75	31.36	31.34	31.29	31.53	35.19	35.17	35.11	35.36	39.47	39.44	39.39	39.63							
TotalPower	6,329	6,323	6,311	6,364	7,021	7,016	7,004	7,794	7,788	7,777	7,830	8,630	8,625	8,613	8,666	9,565	9,559	9,547	9,600							

IDB: Entering Indoor Dry Bulb Temperature
 High and low pressures are measured at the liquid and suction access fittings.
 Design Subcooling, 16 - 19 °F @ the liquid access fitting connection ARI 95 test conditions. Design Superheat 8 - 12 °F @ the compressor suction access fitting connection.

Shaded area reflects ACCA (TVA) conditions
 kW = Total system power
 Amps: Unit amps (comp.+ evaporator + condenser fan motors)
 Suction: amp (compressor suction access fitting connection).

IDB		Outdoor Ambient Temperature												105												115											
		65						75						85						95						105						115					
		Entering Indoor Wet Bulb Temperature												105												115											
Airflow	ID WB	59	63	67	71	59	63	67	71	59	63	67	71	59	63	67	71	59	63	67	71	59	63	67	71	59	63	67	71								
2975	Capacity	99,794	101,188	104,136	108,639	98,911	100,304	103,252	107,756	96,334	97,727	100,676	105,179	91,900	93,294	96,242	100,745	86,482	87,875	90,823	95,327	81,535	82,929	85,877	90,380												
	S/T	1.00	0.79	0.66	0.52	1.00	0.80	0.67	0.53	1.00	0.69	0.55	0.42	1.00	0.71	0.57	0.44	1.00	0.73	0.59	0.46	1.00	0.73	0.59	0.46												
	Evap dT	25.96	24.22	20.98	17.62	25.91	24.18	20.93	17.57	26.16	24.42	21.18	17.82	25.90	24.16	20.92	17.56	25.66	23.93	20.68	17.32	26.75	25.01	21.77	18.41												
	Pr Suc	130.18	131.77	135.04	140.53	138.01	139.60	142.88	148.36	144.87	146.46	149.74	155.22	150.67	152.26	155.54	161.03	156.37	157.96	161.24	166.72	163.49	165.09	168.36	173.85												
	Pr Dis	266.62	267.77	269.64	274.25	308.42	309.57	311.44	316.05	352.22	353.37	355.23	359.85	399.37	400.52	402.38	407.00	450.21	451.36	453.22	457.84	504.47	505.62	507.48	512.10												
	ODamps	24.38	24.35	24.30	24.54	27.55	27.52	27.47	27.71	31.09	31.06	31.01	31.25	34.91	34.89	34.83	35.08	39.19	39.16	39.11	39.35	44.21	44.18	44.13	44.37												
	TotalPower	6,268	6,262	6,250	6,303	6,960	6,955	6,943	6,996	7,733	7,727	7,716	7,769	8,569	8,564	8,552	8,605	9,504	9,498	9,486	9,539	10,600	10,595	10,583	10,636												
	Capacity	100,552	101,945	104,893	109,397	99,668	101,062	104,010	108,513	97,091	98,485	101,433	105,936	92,658	94,051	96,999	101,503	87,239	88,633	91,581	96,084	82,292	83,686	86,634	91,137												
	S/T	1.00	0.82	0.69	0.55	1.00	0.83	0.70	0.56	1.00	0.70	0.58	0.45	1.00	0.74	0.60	0.47	1.00	0.76	0.62	0.49	1.00	0.76	0.62	0.49												
	Evap dT	25.40	23.66	20.42	17.06	25.35	23.61	20.37	17.01	25.59	23.86	20.61	17.25	25.33	23.59	20.35	16.99	25.10	23.36	20.12	16.76	26.19	24.45	21.21	17.85												
Pr Suc	131.26	132.85	136.13	141.61	139.09	140.68	143.96	149.45	145.95	147.55	150.82	156.31	151.76	153.35	156.63	162.11	157.45	159.04	162.32	167.80	164.58	166.17	169.45	174.93													
Pr Dis	267.87	269.02	270.88	275.50	309.67	310.82	312.68	317.30	353.46	354.61	356.48	361.09	400.62	401.77	403.63	408.25	451.46	452.61	454.47	459.09	505.72	506.86	508.73	513.34													
ODamps	24.47	24.44	24.39	24.63	27.64	27.61	27.56	27.80	31.17	31.15	31.09	31.34	35.00	34.98	34.92	35.16	39.28	39.25	39.20	39.44	44.30	44.27	44.22	44.46													
TotalPower	6,287	6,282	6,270	6,323	6,979	6,974	6,962	7,015	7,752	7,747	7,735	7,788	8,589	8,583	8,571	8,624	9,523	9,518	9,506	9,559	10,619	10,614	10,602	10,655													
Capacity	103,119	104,513	107,461	111,964	102,235	103,629	106,577	111,080	99,659	101,052	104,000	108,504	95,225	96,619	99,567	104,070	89,806	91,200	94,148	98,651	84,860	86,254	89,202	93,705													
S/T	1.00	0.86	0.73	0.59	1.00	0.87	0.74	0.60	1.00	0.76	0.62	0.49	1.00	0.78	0.64	0.51	1.00	0.80	0.66	0.53	1.00	0.80	0.66	0.53													
Evap dT	24.06	22.33	19.08	15.72	24.02	22.28	19.04	15.68	24.26	22.52	19.28	15.92	24.00	22.26	19.02	15.66	23.77	22.03	18.79	15.43	24.85	23.12	19.87	16.51													
Pr Suc	134.66	136.25	139.53	145.01	142.49	144.08	147.36	152.85	149.35	150.95	154.22	159.71	155.16	156.75	160.02	165.51	160.85	162.44	165.72	171.20	167.98	169.57	172.85	178.33													
Pr Dis	271.30	272.45	274.31	278.93	313.10	314.25	316.11	320.73	356.89	358.04	359.91	364.52	404.05	405.20	407.06	411.68	454.89	456.04	457.90	462.52	509.15	510.30	512.16	516.78													
ODamps	24.68	24.65	24.60	24.84	27.84	27.82	27.76	28.01	31.38	31.36	31.30	31.54	35.21	35.18	35.13	35.37	39.49	39.46	39.41	39.65	44.50	44.48	44.42	44.67													
TotalPower	6,332	6,327	6,315	6,368	7,025	7,019	7,007	7,060	7,798	7,792	7,780	7,833	8,634	8,628	8,617	8,670	9,568	9,563	9,551	9,604	10,665	10,659	10,647	10,700													
2975	Capacity	101,457	102,851	105,799	110,302	100,573	101,967	104,915	109,418	97,996	99,390	102,338	106,841	93,563	94,957	97,905	102,408	88,144	89,538	92,486	96,989	83,198	84,592	87,540	92,043												
	S/T	1.00	0.89	0.76	0.62	1.00	0.90	0.76	0.63	1.00	0.79	0.65	0.52	1.00	0.81	0.67	0.54	1.00	0.83	0.69	0.56	1.00	0.83	0.69	0.56												
	Evap dT	29.37	27.63	24.39	21.03	29.32	27.59	24.34	20.98	29.57	27.83	24.59	21.23	29.31	27.57	24.33	20.97	29.07	27.34	24.09	20.73	30.16	28.42	25.18	21.82												
	Pr Suc	132.11	133.70	136.98	142.46	139.94	141.53	144.81	150.29	146.80	148.39	151.67	157.15	152.60	154.19	157.47	162.96	158.30	159.89	163.17	168.65	165.42	167.02	170.29	175.78												
	Pr Dis	267.87	269.02	270.88	275.50	309.67	310.82	312.68	317.30	353.46	354.61	356.47	361.09	400.62	401.77	403.63	408.25	451.46	452.61	454.47	459.09	505.71	506.86	508.73	513.34												
	ODamps	24.44	24.41	24.36	24.60	27.61	27.58	27.53	27.77	31.15	31.12	31.07	31.31	34.97	34.95	34.89	35.14	39.25	39.23	39.17	39.41	44.27	44.24	44.19	44.43												
	TotalPower	6,281	6,275	6,264	6,317	6,973	6,968	6,956	7,009	7,746	7,741	7,729	7,782	8,582	8,577	8,565	8,618	9,517	9,511	9,500	9,553	10,613	10,608	10,596	10,649												
	Capacity	102,214	103,608	106,556	111,059	101,331	102,725	105,673	110,176	98,754	100,148	103,096	107,599	94,320	95,714	98,662	103,165	88,902	90,296	93,244	97,747	83,955	85,349	88,297	92,800												
	S/T	1.00	0.92	0.79	0.65	1.00	0.91	0.79	0.65	1.00	0.82	0.68	0.55	1.00	0.84	0.70	0.57	1.00	0.86	0.72	0.59	1.00	0.86	0.72	0.59												
	Evap dT	28.81	27.07	23.83	20.47	28.76	27.02	23.78	20.42	29.00	27.27	24.02	20.66	28.74	27.00	23.76	20.40	28.51	26.77	23.53	20.17	29.60	27.86	24.62	21.26												
Pr Suc	133.19	134.78	138.06	143.54	141.02	142.61	145.89	151.38	147.89	149.48	152.76	158.24	153.69	155.28	158.56	164.04	159.38	160.97	164.25	169.73	166.51	168.10	171.38	176.86													
Pr Dis	269.12	270.27	272.13	276.75	310.92	312.07	313.93	318.55	354.71	355.86	357.72	362.34	401.86	403.01	404.88	409.49	452.71	453.85	455.72	460.33	506.96	508.11	509.97	514.59													
ODamps	24.53	24.50	24.45	24.69	27.70	27.67	27.62	27.86	31.23	31.21	31.15	31.40	35.06	35.04	34.98	35.22	39.34	39.31	39.26	39.50	44.36	44.33	44.28	44.52													
TotalPower	6,300	6,295	6,283	6,336	6,993	6,987	6,975	7,028	7,765	7,760	7,748	7,801	8,602	8,596	8,584	8,637	9,536	9,531	9,519	9,572	10,633	10,627	10,615	10,668													
Capacity	104,782	106,176	109,124	113,627	103,898	105,292	108,240	112,743	101,321	102,715	105,663	110,166	96,888	98,282	101,230	105,733	91,469	92,863	95,811	100,314	86,523	87,916	90,864	95,368													
S/T	1.00	1.00	0.83	0.69	1.00	1.00	0.84	0.70	1.00	0.86	0.72	0.59	1.00	0.88	0.74	0.61	1.00	0.90	0.76	0.63	1.00	0.90	0.76	0.63													
Evap dT	27.47	25.74	22.49	19.13	27.43	25.69	22.45	19.09	27.67	25.93	22.69	19.33	27.41	25.67	22.43	19.07	27.18	25.44	22.20	18.84	28.26	26.53	23.28	19.92													
Pr Suc	136.59	138.18	141.46	146.94	144.42	146.01	149.29	154.78	151.28	152.88	156.15	161.64	157.09	158.68	161.96	167.44	162.78	164.37	167.65	173.13	169.91	171.50	174.78	180.26													
Pr Dis	272.55	273.70	275.56	280.18	314.35	315.50	317.36	321.98	358.14	359.29	361.15	365.77	405.30	406.44	408.31	412.92	456.14	457.28	459.15	463.76	510.39	511.54	513.40	518.02													
ODamps	24.74	24.71	24.66	24.90	27.90	27.88	27.83	28.07	31.44	31.42	31.36	31.60	35.27	35.24	35.19	35.43	39.55	39.52	39.47	39.71	44.56	44.54	44.48	44.73													
TotalPower	6,346	6,340	6,328	6,381	7,038	7,033	7,021	7,074	7,811	7,805	7,794	7,846	8,647	8,642	8,630	8,683	9,582	9,576	9,564	9,617	10,678	10,672	10,661	10,714													

IDB: Entering Indoor Dry Bulb Temperature
 High and low pressures are measured at the liquid and suction access fittings.
 Design Subcooling, 16 - 19 °F @ the liquid access fitting connection ARI 95 test conditions. Design Superheat 8 - 12 °F @ the compressor suction access fitting connection.

Shaded area reflects ACCA (TVA) conditions
 kW = Total system power
 Amps: Unit amps (comp. + evaporator + condenser fan motors)

IDB		Airflow		Outdoor Ambient Temperature																	
				65			75			85			95			105			115		
				59	63	67	71	59	63	67	71	59	63	67	71	59	63	67	71	59	63
70	3150	Capacity	118,689	120,356	123,881	117,632	119,299	122,825	114,551	116,218	119,743	109,249	110,916	114,441	102,769	104,436	107,961	96,853	98,520	102,046	
		S/T	0.62	0.55	0.41	0.63	0.55	0.42	1.00	0.58	0.44	1.00	0.59	0.46	1.00	0.62	0.48	1.00	1.00	0.53	
		Evap dT	20.10	18.19	14.62	20.05	18.14	14.57	20.32	18.41	14.84	20.03	18.12	14.55	19.77	17.86	14.30	20.97	19.06	15.49	
		Pr Suc	134.10	135.75	139.14	142.21	143.86	147.25	149.31	150.96	154.35	155.31	156.96	160.35	161.20	162.85	166.24	168.58	170.22	173.62	
		Pr Dis	273.70	274.89	276.80	316.72	317.91	319.82	361.79	362.98	364.89	410.33	411.51	413.43	462.65	463.83	465.75	518.49	519.67	521.59	
		ODamps	28.24	28.21	28.14	32.32	32.29	32.22	36.88	36.84	36.77	41.80	41.77	41.70	47.31	47.28	47.21	53.77	53.74	53.67	
		TotalPower	7,292	7,285	7,269	8,183	8,176	8,161	9,178	9,171	9,156	10,281	10,274	10,259	11,484	11,477	11,462	12,870	12,863	12,848	
		Capacity	119,648	121,314	124,840	118,591	120,258	123,784	115,509	117,176	120,702	110,207	111,874	115,400	103,728	105,394	108,920	97,812	99,479	103,004	
		S/T	0.65	0.58	0.44	1.00	0.58	0.45	1.00	0.61	0.47	1.00	0.62	0.49	1.00	1.00	0.51	1.00	1.00	0.56	
		Evap dT	19.45	17.54	13.97	19.40	17.49	13.92	19.67	17.76	14.19	19.38	17.47	13.90	19.12	17.21	13.65	20.32	18.41	14.84	
Pr Suc	135.29	136.93	140.33	143.39	145.04	148.43	150.49	152.14	155.53	156.49	158.14	161.53	162.39	164.03	167.42	169.76	171.41	174.80			
Pr Dis	275.05	276.24	278.15	318.07	319.26	321.17	363.14	364.33	366.24	411.67	412.86	414.77	464.00	465.18	467.10	519.84	521.02	522.94			
ODamps	28.36	28.33	28.26	32.44	32.41	32.34	36.99	36.96	36.89	41.92	41.89	41.82	47.43	47.40	47.33	53.89	53.86	53.79			
TotalPower	7,318	7,311	7,295	8,209	8,202	8,187	9,204	9,197	9,182	10,281	10,274	10,259	11,484	11,477	11,462	12,896	12,889	12,874			
Capacity	122,690	124,357	127,882	121,634	123,300	126,826	118,552	120,219	123,744	113,250	114,917	118,442	106,770	108,437	111,962	100,854	102,521	106,047			
S/T	0.69	0.62	0.48	1.00	0.62	0.49	1.00	0.65	0.51	1.00	0.66	0.53	1.00	1.00	0.55	1.00	1.00	0.60			
Evap dT	18.01	16.10	12.54	17.96	16.05	12.47	18.23	16.32	12.75	17.94	16.03	12.47	17.69	15.78	12.21	18.88	16.97	13.41			
Pr Suc	138.76	140.41	143.80	146.87	148.52	151.91	153.97	155.62	159.01	159.97	161.62	165.01	165.86	167.51	170.90	173.24	174.89	178.28			
Pr Dis	278.53	279.71	281.63	321.55	322.73	324.65	366.62	367.80	369.72	415.15	416.33	418.25	467.48	468.66	470.58	523.32	524.50	526.42			
ODamps	28.62	28.59	28.52	32.70	32.67	32.60	37.26	37.22	37.15	42.19	42.15	42.08	47.69	47.66	47.59	54.15	54.12	54.05			
TotalPower	7,375	7,368	7,353	8,266	8,259	8,244	9,262	9,255	9,239	10,338	10,331	10,316	11,542	11,535	11,519	12,953	12,946	12,931			

70	3150	Capacity	118,689	120,356	123,881	117,632	119,299	122,825	114,551	116,218	119,743	109,249	110,916	114,441	102,769	104,436	107,961	96,853	98,520	102,046
		S/T	0.62	0.55	0.41	0.63	0.55	0.42	1.00	0.58	0.44	1.00	0.59	0.46	1.00	0.62	0.48	1.00	1.00	0.53
		Evap dT	20.10	18.19	14.62	20.05	18.14	14.57	20.32	18.41	14.84	20.03	18.12	14.55	19.77	17.86	14.30	20.97	19.06	15.49
		Pr Suc	134.10	135.75	139.14	142.21	143.86	147.25	149.31	150.96	154.35	155.31	156.96	160.35	161.20	162.85	166.24	168.58	170.22	173.62
		Pr Dis	273.70	274.89	276.80	316.72	317.91	319.82	361.79	362.98	364.89	410.33	411.51	413.43	462.65	463.83	465.75	518.49	519.67	521.59
		ODamps	28.24	28.21	28.14	32.32	32.29	32.22	36.88	36.84	36.77	41.80	41.77	41.70	47.31	47.28	47.21	53.77	53.74	53.67
		TotalPower	7,292	7,285	7,269	8,183	8,176	8,161	9,178	9,171	9,156	10,281	10,274	10,259	11,484	11,477	11,462	12,870	12,863	12,848
		Capacity	119,648	121,314	124,840	118,591	120,258	123,784	115,509	117,176	120,702	110,207	111,874	115,400	103,728	105,394	108,920	97,812	99,479	103,004
		S/T	0.65	0.58	0.44	1.00	0.58	0.45	1.00	0.61	0.47	1.00	0.62	0.49	1.00	1.00	0.51	1.00	1.00	0.56
		Evap dT	19.45	17.54	13.97	19.40	17.49	13.92	19.67	17.76	14.19	19.38	17.47	13.90	19.12	17.21	13.65	20.32	18.41	14.84
Pr Suc	135.29	136.93	140.33	143.39	145.04	148.43	150.49	152.14	155.53	156.49	158.14	161.53	162.39	164.03	167.42	169.76	171.41	174.80		
Pr Dis	275.05	276.24	278.15	318.07	319.26	321.17	363.14	364.33	366.24	411.67	412.86	414.77	464.00	465.18	467.10	519.84	521.02	522.94		
ODamps	28.36	28.33	28.26	32.44	32.41	32.34	36.99	36.96	36.89	41.92	41.89	41.82	47.43	47.40	47.33	53.89	53.86	53.79		
TotalPower	7,318	7,311	7,295	8,209	8,202	8,187	9,204	9,197	9,182	10,281	10,274	10,259	11,484	11,477	11,462	12,896	12,889	12,874		
Capacity	122,690	124,357	127,882	121,634	123,300	126,826	118,552	120,219	123,744	113,250	114,917	118,442	106,770	108,437	111,962	100,854	102,521	106,047		
S/T	0.69	0.62	0.48	1.00	0.62	0.49	1.00	0.65	0.51	1.00	0.66	0.53	1.00	1.00	0.55	1.00	1.00	0.60		
Evap dT	18.01	16.10	12.54	17.96	16.05	12.47	18.23	16.32	12.75	17.94	16.03	12.47	17.69	15.78	12.21	18.88	16.97	13.41		
Pr Suc	138.76	140.41	143.80	146.87	148.52	151.91	153.97	155.62	159.01	159.97	161.62	165.01	165.86	167.51	170.90	173.24	174.89	178.28		
Pr Dis	278.53	279.71	281.63	321.55	322.73	324.65	366.62	367.80	369.72	415.15	416.33	418.25	467.48	468.66	470.58	523.32	524.50	526.42		
ODamps	28.62	28.59	28.52	32.70	32.67	32.60	37.26	37.22	37.15	42.19	42.15	42.08	47.69	47.66	47.59	54.15	54.12	54.05		
TotalPower	7,375	7,368	7,353	8,266	8,259	8,244	9,262	9,255	9,239	10,338	10,331	10,316	11,542	11,535	11,519	12,953	12,946	12,931		

IDB: Entering Indoor Dry Bulb Temperature
 High and low pressures are measured at the liquid and suction access fittings.
 Design Subcooling, 16 - 19 °F @ the liquid access fitting connection ARI 95 test conditions. Design Superheat 8 - 12°F @ the compressor suction access fitting connection.

Shaded area reflects ACCA (TVA) conditions
 kW = Total system power
 Amps: Unit amps (comp.+ evaporator + condenser fan motors)
 suction access fitting connection.

IDB	Airflow	ID WB	Outdoor Ambient Temperature																							
			65				75				85				95				105				115			
			59	63	67	71	59	63	67	71	59	63	67	71	59	63	67	71	59	63	67	71	59	63	67	71
80	3150	Capacity	119,369	121,036	124,561	129,947	118,313	119,979	123,505	128,890	115,231	116,898	120,423	125,808	109,929	111,596	115,121	120,506	103,449	105,116	108,641	114,027	97,533	99,200	102,726	108,111
		S/T	1.00	0.79	0.66	0.52	1.00	0.80	0.67	0.53	1.00	0.69	0.55	0.41	1.00	0.71	0.57	0.43	1.00	1.00	0.73	0.59	1.00	1.00	1.00	0.64
		Evap dT	28.53	26.62	23.05	19.36	28.48	26.57	23.00	19.30	28.74	26.83	23.27	19.57	28.46	26.55	22.98	19.28	28.20	26.29	22.72	19.03	29.40	27.49	23.92	20.23
		Pr Svc	134.72	136.37	139.76	145.44	142.83	144.48	147.87	153.50	149.93	151.58	154.97	160.64	155.93	157.58	160.97	166.64	161.82	163.47	166.86	172.53	169.20	170.84	174.24	179.91
		Pr Dis	274.45	275.63	277.55	282.30	317.47	318.65	320.57	325.32	362.54	363.72	365.64	370.39	411.07	412.25	414.17	418.92	463.39	464.58	466.49	471.24	519.23	520.41	522.33	527.08
		ODamps	28.24	28.20	28.13	28.45	32.32	32.28	32.21	32.53	36.87	36.84	36.77	37.08	41.80	41.77	41.70	42.01	47.31	47.27	47.20	47.52	53.77	53.73	53.67	53.98
		TotalPower	7,290	7,283	7,268	7,336	8,182	8,175	8,160	8,228	9,177	9,170	9,155	9,223	10,254	10,247	10,232	10,300	11,457	11,450	11,435	11,503	12,869	12,862	12,847	12,915
		Capacity	120,328	121,995	125,520	130,905	119,271	120,938	124,464	129,849	116,190	117,856	121,382	126,767	110,888	112,554	116,080	121,465	104,408	106,075	109,600	114,985	98,492	100,159	103,685	109,070
		S/T	1.00	0.82	0.69	0.55	1.00	1.00	0.70	0.56	1.00	1.00	0.72	0.58	1.00	0.74	0.60	0.46	1.00	1.00	0.62	0.48	1.00	1.00	1.00	0.67
		Evap dT	27.88	25.97	22.40	18.71	27.83	25.92	22.35	18.66	28.10	26.19	22.62	18.92	27.81	25.90	22.33	18.64	27.55	25.64	22.08	18.38	28.75	26.84	23.27	19.58
Pr Svc	135.91	137.55	140.95	146.62	144.01	145.66	149.05	154.73	151.11	152.76	156.15	161.83	157.11	158.76	162.15	167.83	163.01	164.65	168.04	173.72	170.38	172.03	175.44	181.09		
Pr Dis	275.80	276.98	278.90	283.65	318.82	320.00	321.92	326.67	363.89	365.07	366.99	371.74	412.42	413.60	415.52	420.27	464.74	465.92	467.84	472.59	520.58	521.76	523.68	528.43		
ODamps	28.35	28.32	28.25	28.56	32.43	32.40	32.33	32.64	36.99	36.96	36.89	37.20	41.92	41.89	41.82	42.13	47.43	47.39	47.32	47.64	53.89	53.85	53.78	54.10		
TotalPower	7,316	7,309	7,294	7,362	8,208	8,201	8,186	8,254	9,203	9,196	9,181	9,249	10,280	10,273	10,258	10,326	11,483	11,476	11,461	11,529	12,895	12,888	12,873	12,941		
Capacity	123,370	125,037	128,563	133,948	122,314	123,981	127,506	132,891	119,232	120,899	124,424	129,810	113,930	115,597	119,122	124,507	107,450	109,117	112,642	118,028	101,535	103,201	106,727	112,112		
S/T	1.00	0.86	0.73	0.59	1.00	1.00	0.74	0.60	1.00	1.00	0.76	0.62	1.00	0.78	0.64	0.50	1.00	1.00	0.66	0.52	1.00	1.00	1.00	0.71		
Evap dT	26.44	24.53	20.97	17.27	26.39	24.48	20.91	17.22	26.66	24.75	21.18	17.49	26.37	24.46	20.89	17.20	26.12	24.21	20.64	16.94	27.31	25.40	21.83	18.14		
Pr Svc	139.39	141.03	144.42	150.10	147.49	149.14	152.53	158.20	154.59	156.24	159.63	165.30	160.59	162.24	165.63	171.31	166.48	168.13	171.52	177.20	173.86	175.51	178.90	184.57		
Pr Dis	279.27	280.46	282.37	287.13	322.29	323.48	325.39	330.15	367.36	368.55	370.46	375.22	415.90	417.08	418.99	423.75	468.22	469.40	471.32	476.07	524.06	525.24	527.16	531.91		
ODamps	28.62	28.58	28.51	28.83	32.70	32.66	32.59	32.91	37.25	37.22	37.15	37.46	42.18	42.15	42.08	42.39	47.69	47.66	47.59	47.90	54.15	54.12	54.05	54.36		
TotalPower	7,374	7,367	7,351	7,420	8,265	8,258	8,243	8,311	9,260	9,253	9,238	9,306	10,337	10,330	10,315	10,383	11,541	11,534	11,518	11,587	12,952	12,945	12,930	12,998		

Capacity	121,358	123,024	126,550	131,935	120,301	121,968	125,493	130,879	117,219	118,886	122,412	127,797	111,917	113,584	117,110	122,495	105,437	107,104	110,630	116,015	99,522	101,189	104,714	110,099
S/T	1.00	1.00	0.76	0.62	1.00	1.00	0.77	0.63	1.00	1.00	0.79	0.65	1.00	1.00	0.70	0.56	1.00	1.00	0.69	0.55	1.00	1.00	1.00	0.69
Evap dT	32.28	30.37	26.80	23.11	32.23	30.32	26.75	23.05	32.49	30.58	27.02	23.32	32.21	30.30	26.73	23.03	31.95	30.04	26.47	22.78	33.15	31.24	27.67	23.98
Pr Svc	136.72	138.37	141.76	147.43	144.83	146.47	149.87	155.54	151.93	153.57	156.97	162.64	157.93	159.57	162.97	168.64	163.82	165.47	168.86	174.53	171.20	172.84	176.23	181.91
Pr Dis	275.73	276.91	278.83	283.58	318.75	319.93	321.85	326.60	363.82	365.00	366.92	371.67	412.35	413.53	415.45	420.20	464.67	465.86	467.77	472.53	520.51	521.70	523.61	528.37
ODamps	28.31	28.28	28.21	28.52	32.39	32.36	32.29	32.60	36.95	36.92	36.85	37.16	41.88	41.85	41.78	42.09	47.38	47.35	47.28	47.59	53.85	53.81	53.74	54.06
TotalPower	7,308	7,301	7,285	7,353	8,199	8,192	8,177	8,245	9,194	9,187	9,172	9,240	10,271	10,264	10,249	10,317	11,474	11,467	11,452	11,520	12,886	12,879	12,864	12,932
Capacity	122,316	123,983	127,509	132,894	121,260	122,927	126,452	131,837	118,178	119,845	123,371	128,756	112,876	114,543	118,068	123,454	106,396	108,063	111,589	116,974	100,481	102,148	105,673	111,058
S/T	1.00	1.00	0.79	0.65	1.00	1.00	0.80	0.66	1.00	1.00	0.82	0.68	1.00	1.00	0.70	0.56	1.00	1.00	0.72	0.58	1.00	1.00	1.00	0.71
Evap dT	31.63	29.72	26.15	22.46	31.58	29.67	26.10	22.41	31.85	29.94	26.37	22.67	31.56	29.65	26.08	22.39	31.30	29.39	25.83	22.13	32.50	30.59	27.02	23.33
Pr Svc	137.90	139.55	142.94	148.62	146.01	147.66	151.05	156.72	153.11	154.76	158.15	163.82	159.11	160.76	164.15	169.82	165.00	166.65	170.04	175.72	172.38	174.03	177.42	183.09
Pr Dis	277.08	278.26	280.18	284.93	320.10	321.28	323.20	327.95	365.17	366.35	368.27	373.02	413.70	414.88	416.80	421.55	466.02	467.21	469.12	473.88	521.86	523.05	524.96	529.72
ODamps	28.43	28.40	28.33	28.64	32.51	32.48	32.41	32.72	37.07	37.04	36.97	37.28	42.00	41.96	41.89	42.21	47.50	47.47	47.40	47.71	53.96	53.93	53.86	54.17
TotalPower	7,334	7,326	7,311	7,379	8,225	8,218	8,203	8,271	9,220	9,213	9,198	9,266	10,297	10,290	10,275	10,343	11,500	11,493	11,478	11,546	12,912	12,905	12,890	12,958
Capacity	125,359	127,026	130,551	135,936	124,302	125,969	129,495	134,880	121,221	122,887	126,413	131,798	115,918	117,585	121,111	126,496	109,439	111,106	114,631	120,016	103,523	105,190	108,715	114,101
S/T	1.00	1.00	0.83	0.69	1.00	1.00	0.84	0.70	1.00	1.00	0.86	0.72	1.00	1.00	0.74	0.60	1.00	1.00	0.76	0.62	1.00	1.00	1.00	0.71
Evap dT	30.19	28.28	24.72	21.02	30.14	28.23	24.66	20.97	30.41	28.50	24.93	21.24	30.12	28.21	24.64	20.95	29.87	27.96	24.39	20.69	31.06	29.15	25.58	21.89
Pr Svc	141.38	143.03	146.42	152.09	149.49	151.13	154.53	160.20	156.59	158.23	161.63	167.30	162.59	164.24	167.63	173.30	168.48	170.13	173.52	179.19	175.86	177.50	180.90	186.57
Pr Dis	280.56	281.74	283.66	288.41	323.58	324.76	326.68	331.43	368.65	369.83	371.75	376.50	417.18	418.36	420.28	425.03	469.50	470.68	472.60	477.35	525.34	526.52	528.44	533.19
ODamps	28.69	28.66	28.59	28.90	32.77	32.74	32.67	32.99	37.33	37.30	37.23	37.54	42.26	42.23	42.16	42.47	47.77	47.73	47.66	47.98	54.23	54.19	54.12	54.44
TotalPower	7,391	7,384	7,369	7,437	8,282	8,275	8,260	8,328	9,277	9,270	9,255	9,323	10,354	10,347	10,332	10,400	11,558	11,551	11,535	11,604	12,969	12,962	12,947	13,015

IDB: Entering Indoor Dry Bulb Temperature
 High and low pressures are measured at the liquid and suction access fittings.
 Design Subcooling, 16 - 19 °F @ the liquid access fitting connection ARI 95 test conditions. Design Superheat 8 - 12 °F @ the compressor suction access fitting connection.

Shaded area reflects ACCA (TVA) conditions
 kW = Total system power
 Amps: Unit amps (comp. + evaporator + condenser fan motors)
 Amps: compressor suction access fitting connection.

IDB	Airflow	ID WB	Outdoor Ambient Temperature																							
			65				75				85				95				105				115			
			59	63	67	71	59	63	67	71	59	63	67	71	59	63	67	71	59	63	67	71	59	63	67	71
		Capacity	143,021	145,033	149,288	141,746	143,758	148,013	138,027	140,038	144,293	131,628	133,639	137,894	123,807	125,819	130,074	116,668	118,680	122,934						
		S/T	0.59	0.52	0.39	1.00	0.53	0.40	1.00	0.55	0.42	1.00	0.57	0.44	1.00	1.00	0.46	1.00	1.00	0.51						
		Evap dT	19.72	17.86	14.38	19.67	17.81	14.33	19.93	18.07	14.59	19.65	17.79	14.31	19.40	17.54	14.06	20.56	18.70	15.23						
	3850	Pr Suc	136.09	137.76	141.21	144.33	146.00	149.45	151.55	153.22	156.67	157.65	159.32	162.77	163.64	165.31	168.76	171.14	172.81	176.26						
		Pr Dis	269.31	270.48	272.36	311.69	312.85	314.74	356.08	357.24	359.13	403.88	405.04	406.93	455.42	456.58	458.47	510.42	511.58	513.47						
		ODamps	32.65	32.62	32.54	37.28	37.24	37.16	42.44	42.40	42.32	48.03	47.99	47.91	54.27	54.23	54.15	61.59	61.55	61.47						
		TotalPower	9,006	8,998	8,981	10,016	10,008	9,991	11,144	11,136	11,119	12,365	12,357	12,339	13,728	13,720	13,703	15,328	15,320	15,303						
		Capacity	144,305	146,317	150,572	143,030	145,042	149,297	139,311	141,322	145,577	132,912	134,923	139,178	125,091	127,103	131,358	117,952	119,963	124,218						
		S/T	0.63	0.56	0.43	1.00	0.56	0.43	1.00	0.59	0.46	1.00	0.60	0.48	1.00	1.00	0.50	1.00	1.00	0.55						
		Evap dT	18.99	17.13	13.66	18.94	17.08	13.61	19.20	17.34	13.87	18.92	17.06	13.59	18.67	16.81	13.34	19.84	17.98	14.50						
	4200	Pr Suc	137.43	139.11	142.56	145.67	147.35	150.80	152.89	154.56	158.01	158.99	160.67	164.12	164.98	166.66	170.10	172.48	174.15	177.60						
		Pr Dis	270.81	271.98	273.87	313.19	314.35	316.24	357.58	358.75	360.63	405.38	406.55	408.44	456.92	458.09	459.97	511.92	513.09	514.97						
		ODamps	32.81	32.77	32.69	37.43	37.40	37.32	42.59	42.56	42.48	48.18	48.14	48.06	54.42	54.38	54.31	61.74	61.71	61.63						
		TotalPower	9,040	9,032	9,014	10,050	10,042	10,025	11,178	11,170	11,153	12,398	12,390	12,373	13,762	13,754	13,737	15,362	15,354	15,337						
		Capacity	147,650	149,661	153,916	146,375	148,386	152,641	142,655	144,667	148,922	136,256	138,268	142,523	128,436	130,447	134,702	121,296	123,308	127,563						
		S/T	0.67	0.60	0.47	1.00	0.60	0.47	1.00	0.63	0.50	1.00	1.00	0.52	1.00	1.00	0.54	1.00	1.00	0.59						
		Evap dT	17.68	15.82	12.34	17.63	15.77	12.29	17.89	16.03	12.55	17.61	15.75	12.27	17.36	15.50	12.02	18.52	16.66	13.19						
	4950	Pr Suc	140.67	142.35	145.80	148.91	150.59	154.04	156.13	157.80	161.25	162.23	163.91	167.36	168.22	169.90	173.34	175.72	177.39	180.84						
		Pr Dis	273.99	275.15	277.04	316.36	317.53	319.42	360.76	361.92	363.81	408.56	409.72	411.61	460.10	461.26	463.15	515.10	516.26	518.15						
		ODamps	33.09	33.05	32.97	37.71	37.68	37.60	42.87	42.84	42.76	48.46	48.42	48.34	54.70	54.66	54.59	62.02	61.99	61.91						
		TotalPower	9,101	9,093	9,075	10,111	10,103	10,086	11,239	11,231	11,214	12,459	12,451	12,434	13,823	13,815	13,798	15,423	15,415	15,398						
		Capacity	143,104	145,116	149,371	141,829	143,841	148,096	138,110	140,122	144,376	131,711	133,722	137,977	123,890	125,902	130,157	116,751	118,763	123,017						
		S/T	1.00	0.64	0.52	1.00	0.65	0.52	1.00	0.67	0.55	1.00	1.00	0.56	1.00	1.00	0.58	1.00	1.00	0.50						
		Evap dT	23.81	21.95	18.47	23.76	21.90	18.42	24.02	22.16	18.68	23.74	21.88	18.40	23.49	21.63	18.15	24.65	22.79	19.32						
	3850	Pr Suc	136.12	137.79	141.24	144.36	146.03	149.48	151.58	153.25	156.70	157.68	159.35	162.80	163.67	165.34	168.79	171.17	172.84	176.29						
		Pr Dis	269.55	270.71	272.60	311.92	313.09	314.98	356.32	357.48	359.37	404.12	405.28	407.17	455.65	456.82	458.71	510.66	511.82	513.71						
		ODamps	32.62	32.59	32.51	37.25	37.21	37.13	42.41	42.37	42.29	48.00	47.96	47.88	54.24	54.20	54.12	61.56	61.52	61.44						
		TotalPower	8,999	8,991	8,974	10,010	10,002	9,984	11,138	11,130	11,112	12,358	12,350	12,333	13,722	13,714	13,697	15,322	15,314	15,296						
		Capacity	144,388	146,400	150,655	143,113	145,125	149,380	139,394	141,405	145,660	132,995	135,006	139,261	125,174	127,186	131,441	118,035	120,046	124,301						
		S/T	1.00	0.68	0.55	1.00	0.68	0.56	1.00	1.00	0.58	1.00	1.00	0.60	1.00	1.00	0.62	1.00	1.00	0.53						
		Evap dT	23.08	21.22	17.75	23.03	21.17	17.70	23.29	21.43	17.96	23.01	21.15	17.68	22.76	20.90	17.43	23.93	22.07	18.60						
	4200	Pr Suc	137.47	139.14	142.59	145.71	147.38	150.83	152.92	154.60	158.05	159.03	160.70	164.15	165.01	166.69	170.14	172.51	174.19	177.63						
		Pr Dis	271.05	272.22	274.11	313.43	314.59	316.48	357.82	358.98	360.87	405.62	406.79	408.67	457.16	458.32	460.21	512.16	513.32	515.21						
		ODamps	32.78	32.74	32.66	37.40	37.37	37.29	42.56	42.53	42.45	48.15	48.11	48.03	54.39	54.35	54.28	61.71	61.68	61.60						
		TotalPower	9,033	9,025	9,008	10,043	10,035	10,018	11,171	11,163	11,146	12,392	12,384	12,367	13,755	13,748	13,730	15,355	15,347	15,330						
		Capacity	147,733	149,744	153,999	146,458	148,469	152,724	142,738	144,750	149,005	136,339	138,351	142,606	128,519	130,531	134,785	121,379	123,391	127,646						
		S/T	1.00	0.72	0.59	1.00	0.72	0.60	1.00	1.00	0.62	1.00	1.00	0.64	1.00	1.00	0.66	1.00	1.00	0.57						
		Evap dT	21.77	19.91	16.43	21.72	19.86	16.38	21.98	20.12	16.64	21.70	19.84	16.36	21.45	19.59	16.11	22.61	20.75	17.28						
	4950	Pr Suc	140.71	142.38	145.83	148.95	150.62	154.07	156.16	157.84	161.29	162.27	163.94	167.39	168.25	169.93	173.38	175.75	177.43	180.87						
		Pr Dis	274.23	275.39	277.28	316.60	317.77	319.65	360.99	362.16	364.05	408.79	409.96	411.85	460.33	461.50	463.39	515.33	516.50	518.39						
		ODamps	33.06	33.02	32.94	37.68	37.65	37.57	42.84	42.81	42.73	48.43	48.39	48.31	54.67	54.63	54.56	61.99	61.96	61.88						
		TotalPower	9,094	9,086	9,069	10,104	10,096	10,079	11,232	11,224	11,207	12,453	12,445	12,428	13,817	13,809	13,791	15,416	15,409	15,391						

kW = Total system power
 Amps: Unit amps (comp.+ evaporator + condenser fan motors)
 suction access fitting connection.
 Shaded area reflects ACCA (TVA) conditions
 High and low pressures are measured at the liquid and suction access fittings.
 Design Subcooling, 16 - 19 °F @ the liquid access fitting connection ARI 95 test conditions. Design Superheat 8 - 12°F @ the compressor suction access fitting connection.

IDB	Airflow	ID WB	Outdoor Ambient Temperature																													
			65					75					85					95					105					115				
			59	63	67	71	75	59	63	67	71	75	59	63	67	71	75	59	63	67	71	75	59	63	67	71	75	59	63	67	71	75
		Capacity	143,842	145,854	150,109	156,608	142,567	144,579	148,834	155,333	138,848	140,859	145,114	151,614	132,449	134,460	138,715	145,215	124,628	126,640	130,895	137,394	117,489	119,500	123,755	130,255						
		S/T	1.00	0.76	0.63	0.50	1.00	1.00	0.64	0.51	1.00	1.00	0.66	0.53	1.00	1.00	0.68	0.55	1.00	1.00	0.67	0.57	1.00	1.00	0.66	0.52						
		Evap dT	27.93	26.06	22.59	18.99	27.87	26.01	22.54	18.94	28.14	26.28	22.80	19.20	27.86	25.99	22.52	18.92	27.61	25.75	22.27	18.67	28.77	26.91	23.44	19.84						
	3850	Pr Dis	136.72	138.39	141.84	147.61	144.96	146.63	150.08	155.85	152.18	153.85	157.30	163.07	158.28	159.95	163.40	169.17	164.27	165.94	169.39	175.16	171.77	173.44	176.89	182.66						
		Pr Dis	270.04	271.21	273.10	277.78	312.42	313.58	315.47	320.15	356.81	357.97	359.86	364.54	404.61	405.78	407.66	412.35	456.15	457.31	459.20	463.88	511.15	512.31	514.20	518.88						
		ODamps	32.65	32.61	32.53	32.89	37.27	37.24	37.16	37.51	42.43	42.40	42.32	42.67	48.02	47.98	47.90	48.26	54.26	54.22	54.15	54.50	61.58	61.55	61.47	61.82						
		TotalPower	9,005	8,997	8,979	9,057	10,015	10,007	9,990	10,067	11,143	11,135	11,118	11,195	12,363	12,355	12,338	12,415	13,727	13,719	13,702	13,779	15,327	15,319	15,302	15,379						
		Capacity	145,126	147,138	151,393	157,892	143,851	145,863	150,118	156,617	140,132	142,143	146,398	152,898	133,733	135,744	139,999	146,499	125,912	127,924	132,179	138,678	118,773	120,784	125,039	131,539						
		S/T	1.00	0.80	0.67	0.53	1.00	1.00	0.68	0.54	1.00	1.00	0.70	0.56	1.00	1.00	0.72	0.58	1.00	1.00	0.60	0.60	1.00	1.00	0.60	0.65						
		Evap dT	27.20	25.34	21.87	18.27	27.15	25.29	21.82	18.22	27.41	25.55	22.08	18.48	27.13	25.27	21.80	18.20	26.88	25.02	21.55	17.95	28.05	26.19	22.71	19.11						
	4200	Pr Suc	138.06	139.74	143.19	148.95	146.30	147.98	151.43	157.20	153.52	155.20	158.64	164.41	159.62	161.30	164.75	170.51	165.61	167.29	170.73	176.50	173.11	174.78	178.23	184.00						
		Pr Dis	271.55	272.71	274.60	279.28	313.92	315.09	316.97	321.65	358.31	359.48	361.37	366.05	406.11	407.28	409.17	413.85	457.65	458.82	460.71	465.39	512.65	513.82	515.71	520.39						
		ODamps	32.80	32.77	32.69	33.04	37.43	37.39	37.31	37.66	42.59	42.55	42.47	42.83	48.17	48.14	48.06	48.41	54.42	54.38	54.30	54.65	61.74	61.70	61.62	61.98						
		TotalPower	9,038	9,030	9,013	9,090	10,049	10,041	10,023	10,101	11,177	11,169	11,151	11,229	12,397	12,389	12,372	12,449	13,761	13,753	13,736	13,813	15,361	15,353	15,335	15,413						
		Capacity	148,470	150,482	154,737	161,236	147,195	149,207	153,462	159,961	143,476	145,488	149,743	156,242	137,077	139,089	143,344	149,843	129,257	131,268	135,523	142,023	122,117	124,129	128,384	134,883						
		S/T	1.00	0.84	0.71	0.57	1.00	1.00	0.71	0.58	1.00	1.00	0.74	0.60	1.00	1.00	0.62	1.00	1.00	0.64	0.64	1.00	1.00	0.64	0.69							
		Evap dT	25.89	24.03	20.55	16.95	25.83	23.97	20.50	16.90	26.10	24.24	20.76	17.16	25.82	23.96	20.48	16.88	25.57	23.71	20.23	16.63	26.73	24.87	21.40	17.80						
	4950	Pr Suc	141.30	142.98	146.43	152.19	149.54	151.22	154.67	160.43	156.76	158.44	161.88	167.65	162.86	164.54	167.99	173.75	168.85	170.53	173.97	179.74	176.35	178.02	181.47	187.24						
		Pr Dis	274.72	275.89	277.77	282.45	317.09	318.26	320.15	324.83	361.49	362.65	364.54	369.22	409.29	410.45	412.34	417.02	460.83	461.99	463.88	468.56	515.83	516.99	518.88	523.56						
		ODamps	33.08	33.05	32.97	33.32	37.71	37.67	37.59	37.94	42.87	42.83	42.75	43.11	48.45	48.42	48.34	48.69	54.69	54.66	54.58	54.93	62.02	61.98	61.90	62.26						
		TotalPower	9,099	9,091	9,074	9,151	10,110	10,102	10,085	10,162	11,238	11,230	11,212	11,290	12,458	12,450	12,433	12,510	13,822	13,814	13,797	13,874	15,422	15,414	15,397	15,474						
		Capacity	146,242	148,254	152,509	159,008	144,967	146,979	151,234	157,733	141,248	143,259	147,514	154,014	134,849	136,860	141,115	147,615	127,028	129,040	133,295	139,794	119,889	121,900	126,155	132,655						
		S/T	1.00	1.00	0.73	0.60	1.00	1.00	0.74	0.60	1.00	1.00	0.62	1.00	1.00	0.64	0.64	1.00	1.00	0.66	0.66	1.00	1.00	0.66	0.71							
		Evap dT	31.58	29.72	26.24	22.64	31.53	29.67	26.19	22.59	31.79	29.93	26.45	22.86	31.51	29.65	26.17	22.57	31.26	29.40	25.93	22.33	32.42	30.56	27.09	23.49						
	3850	Pr Suc	138.75	140.42	143.87	149.64	146.99	148.66	152.11	157.88	154.21	155.88	159.33	165.10	160.31	161.98	165.43	171.20	166.30	167.97	171.42	177.19	173.80	175.47	178.92	184.69						
		Pr Dis	271.31	272.47	274.36	279.04	313.68	314.84	316.73	321.41	358.07	359.24	361.13	365.81	405.87	407.04	408.93	413.61	457.41	458.58	460.47	465.15	512.41	513.58	515.47	520.15						
		ODamps	32.74	32.70	32.62	32.97	37.36	37.32	37.25	37.60	42.52	42.49	42.41	42.76	48.11	48.07	47.99	48.35	54.35	54.31	54.23	54.59	61.67	61.64	61.56	61.91						
		TotalPower	9,024	9,016	8,999	9,076	10,034	10,026	10,009	10,086	11,162	11,154	11,137	11,214	12,383	12,375	12,357	12,435	13,746	13,738	13,721	13,798	15,346	15,338	15,321	15,398						
		Capacity	147,526	149,538	153,792	160,292	146,251	148,263	152,518	159,017	142,532	144,543	148,798	155,298	136,132	138,144	142,399	148,898	128,312	130,324	134,579	141,078	121,173	123,184	127,439	133,939						
		S/T	1.00	1.00	0.76	0.63	1.00	1.00	0.77	0.64	1.00	1.00	0.66	1.00	1.00	0.68	0.68	1.00	1.00	0.70	0.70	1.00	1.00	0.70	0.75							
		Evap dT	30.85	28.99	25.52	21.92	30.80	28.94	25.47	21.87	31.06	29.20	25.73	22.13	30.78	28.92	25.45	21.85	30.54	28.68	25.20	21.60	31.70	29.84	26.37	22.77						
	4200	Pr Suc	140.09	141.77	145.22	150.98	148.34	150.01	153.46	159.23	155.55	157.23	160.67	166.44	161.65	163.33	166.78	172.54	167.64	169.32	172.77	178.53	175.14	176.82	180.26	186.03						
		Pr Dis	272.81	273.97	275.86	280.54	315.18	316.35	318.24	322.92	359.58	360.74	362.63	367.31	407.38	408.54	410.43	415.11	458.92	460.08	461.97	466.65	513.92	515.08	516.97	521.65						
		ODamps	32.89	32.85	32.78	33.13	37.51	37.48	37.40	37.75	42.68	42.64	42.56	42.92	48.26	48.23	48.15	48.50	54.50	54.47	54.39	54.74	61.83	61.79	61.71	62.06						
		TotalPower	9,058	9,050	9,032	9,110	10,068	10,060	10,043	10,120	11,196	11,188	11,171	11,248	12,416	12,408	12,391	12,468	13,780	13,772	13,755	13,832	15,380	15,372	15,355	15,432						
		Capacity	150,870	152,882	157,137	163,636	149,595	151,607	155,862	162,361	145,876	147,888	152,143	158,642	139,477	141,489	145,744	152,243	131,657	133,668	137,923	144,423	124,517	126,529	130,784	137,283						
		S/T	1.00	1.00	0.80	0.67	1.00	1.00	0.81	0.67	1.00	1.00	0.70	1.00	1.00	0.70	0.72	1.00	1.00	0.70	0.70	1.00	1.00	0.70	0.75							
		Evap dT	29.54	27.68	24.20	20.61	29.49	27.63	24.15	20.55	29.75	27.89	24.41	20.82	29.47	27.61	24.13	20.54	29.22	27.36	23.89	20.29	30.38	28.52	25.05	21.45						
	4950	Pr Suc	143.33	145.01	148.46	154.22	151.58	153.25	156.70	162.47	158.79	160.47	163.91	169.68	164.89	166.57	170.02	175.78	170.88	172.56	176.01	181.77	178.38	180.06	183.50	189.27						
		Pr Dis	275.98	277.15	279.04	283.72	318.36	319.52	321.41	326.09	362.75	363.92	365.80	370.48	410.55	411.72	413.61	418.29	462.09	463.25	465.14	469.82	517.09	518.26	520.14	524.82						
		ODamps	33.17	33.13	33.05	33.41	37.79	37.76	37.68	38.03	42.96	42.92	42.84	43.19	48.54	48.51	48.43	48.78	54.78	54.75	54.67	55.02	62.11	62.07	61.99	62.34						
		TotalPower	9,119	9,111	9,093	9,171	10,129	10,121	10,104	10,181	11,257	11,249	11,232	11,309	12,477	12,470	12,452	12,530	13,841	13,833	13,816	13,893	15,441	15,433	15,416	15,493						

IDB: Entering Indoor Dry Bulb Temperature
 High and low pressures are measured at the liquid and suction access fittings.
 Design Subcooling, 16 - 19 °F @ the liquid access fitting connection ARI 95 test conditions. Design Superheat 8 - 12 °F @ the compressor suction access fitting connection.

Shaded area reflects ACCA (TVA) conditions
 kW = Total system power
 Amps: Unit amps (comp. + evaporator + condenser fan motors)

Heating

Heating Rating Table - Natural Gas and Propane¹

UNIT	Rated High Input (MBH)	Gas Heat	Input/Output (MBH)	Temp Rise High (°F)	Temp Rise Low (°F)	Thermal Efficiency (T.E.)	Recommended Minimum Airflow (SCFM)	Recommended Maximum Airflow (SCFM)
DSG090	130	High	130/105.3	25 - 55		81%	1765	3882
		Low	97.5/79		25-55		1323	2912
	180	High	180/145.8	25 - 55		81%	2443	5375
		Low	135/109.35		25-55		1832	4031
	225	High	225/182.25	30 - 60		81%	2800	5599
		Low	168.75/136.69		30 - 60		2099	4199
DSG102	130	High	130/105.3	25 - 55		81%	1765	3882
		Low	97.5/79		25-55		1323	2912
	180	High	180/145.8	25 - 55		81%	2443	5375
		Low	135/109.35		25-55		1832	4031
	225	High	225/182.25	30 - 60		81%	2800	5599
		Low	168.75/136.69		30 - 60		2099	4199
DSG120	130	High	130/105.3	25 - 55		81%	1765	3882
		Low	97.5/79		25-55		1323	2912
	180	High	180/145.8	25 - 55		81%	2443	5375
		Low	135/109.35		25-55		1832	4031
	240	High	240/194.4	30 - 60		81%	2986	5972
		Low	180/145.8		30 - 60		2240	4479
DSG150	130	High	130/105.3	25 - 55		81%	1765	3882
		Low	97.5/79		25-55		1323	2912
	180	High	180/145.8	25 - 55		81%	2443	5375
		Low	135/109.35		25-55		1832	4031
	240	High	240/194.4	30 - 60		81%	2986	5972
		Low	180/145.8		30 - 60		2240	4479

¹LP High Fire Rate is Reduced 10% that of Natural Gas

7.5 Ton Fan Data • 130 MBH Gas Heat Exchange • Models: DSG0903D, DSG0904D, DSG0907D

Down Flow				
Speed Tap	ESP	CFM	RPM	BHP
T1**	0.2	2085	507	0.33
	0.4	1908	574	0.38
	0.6	1720	641	0.42
	0.8	1550	687	0.45
T2**	0.2	2159	518	0.37
	0.4	1983	583	0.41
	0.6	1801	648	0.46
	0.8	1636	694	0.49
T3	0.2	3030	645	0.85
	0.4	2877	695	0.92
	0.6	2739	744	0.98
	0.8	2627	782	1.03
T4	0.2	3291	684	1.05
	0.4	3146	730	1.12
	0.6	3018	774	1.19
	0.8	2917	811	1.25
T5	0.2	3374	696	1.12
	0.4	3231	741	1.19
		3106	784	1.26
	0.8	3008	821	1.32
T6**	0.2	1625	441	0.16
	0.4	-	-	-
	0.6	-	-	-
	0.8	-	-	-
T7**	0.2	1972	491	0.18
	0.4	1792	560	0.21
	0.6	1598	629	0.23
	0.8	-	-	-
T8	0.2	2304	539	0.43
	0.4	2132	602	0.48
	0.6	1958	664	0.53
	0.8	1803	708	0.57
T9	0.2	3291	684	1.05
	0.4	3146	730	1.12
	0.6	3018	774	1.19
	0.8	2917	811	1.25
T10	0.2	3374	696	1.12
	0.4	3231	741	1.19
	0.6	3106	784	1.26
	0.8	3008	821	1.32

Horizontal Flow				
Speed Tap	ESP	CFM	RPM	BHP
T1**	0.2	2077	498	0.33
	0.4	1910	563	0.37
	0.6	1716	630	0.41
	0.8	-	-	-
T2**	0.2	2152	508	0.36
	0.4	1986	572	0.40
	0.6	1797	638	0.45
	0.8	1531	716	0.51
T3	0.2	3035	632	0.84
	0.4	2892	682	0.90
	0.6	2752	732	0.97
	0.8	2609	784	1.04
T4	0.2	3300	670	1.03
	0.4	3164	717	1.10
	0.6	3036	762	1.17
	0.8	2922	807	1.24
T5	0.2	3384	683	1.10
	0.4	3250	728	1.17
		3126	772	1.24
	0.8	3019	815	1.31
T6**	0.2	1610	433	0.16
	0.4	-	-	-
	0.6	-	-	-
	0.8	-	-	-
T7**	0.2	1962	482	0.18
	0.4	1792	549	0.21
	0.6	1591	618	0.23
	0.8	-	-	-
T8	0.2	2299	528	0.42
	0.4	2137	590	0.47
	0.6	1957	653	0.52
	0.8	1714	727	0.58
T9	0.2	3300	670	1.03
	0.4	3164	717	1.10
	0.6	3036	762	1.17
	0.8	2922	807	1.24
T10	0.2	3384	683	1.10
	0.4	3250	728	1.17
	0.6	3126	772	1.24
	0.8	3019	815	1.31

Shaded speed tap - Gas heating airflow.
 **(T1) (T2) and (T6)(T7) are part load only.

7.5 Ton Fan Data • 130 MBH Gas Heat Exchange • Models: DSG0903L, DSG0904L, DSG0907L

Down Flow					Horizontal Flow				
Speed Tap	ESP	CFM	RPM	BHP	Speed Tap	ESP	CFM	RPM	BHP
T1**	0.2	2159	518	0.37	T1**	0.2	2152	508	0.36
	0.4	1983	583	0.41		0.4	1987	572	0.40
	0.6	1801	648	0.46		0.6	1797	638	0.45
	0.8	1636	694	0.49		0.8	1531	716	0.51
	1	-	-	-		1	-	-	-
	1.2	-	-	-		1.2	-	-	-
T2**	0.2	2410	554	0.48	T2**	0.2	2406	543	0.47
	0.4	2241	615	0.54		0.4	2246	603	0.53
	0.6	2072	675	0.59		0.6	2072	664	0.58
	0.8	1925	718	0.63		0.8	1846	734	0.64
	1	1733	777	0.68		1	1628	802	0.70
	1.2	1530	832	0.72		1.2	-	-	-
T3	0.2	3363	695	1.11	T3	0.2	3370	681	1.09
	0.4	3220	740	1.18		0.4	3236	726	1.16
	0.6	3095	783	1.25		0.6	3111	770	1.23
	0.8	2996	820	1.31		0.8	3005	814	1.30
	1	2871	866	1.38		1	2865	860	1.37
	1.2	2732	907	1.45		1.2	2742	904	1.44
T4	0.2	3622	734	1.35	T4	0.2	3635	720	1.32
	0.4	3487	775	1.42		0.4	3509	762	1.40
	0.6	3369	815	1.50		0.6	3394	802	1.47
	0.8	3278	851	1.56		0.8	3306	841	1.54
	1	3164	893	1.64		1	3184	882	1.62
	1.2	3040	932	1.71		1.2	3070	924	1.69
T5	0.2	3749	753	1.47	T5	0.2	3763	739	1.45
	0.4	3618	793	1.55		0.4	3641	779	1.53
	0.6	3502	832	1.63		0.6	3530	818	1.60
	0.8	3412	867	1.70		0.8	3448	855	1.67
	1	3302	908	1.78		1	3333	894	1.75
	1.2	3184	946	1.85		1.2	3223	935	1.83
T6**	0.2	1934	485	0.27	T6**	0.2	1926	477	0.27
	0.4	1753	555	0.31		0.4	1754	545	0.31
	0.6	1556	625	0.35		0.6	1551	614	0.35
	0.8	-	-	-		0.8	-	-	-
	1	-	-	-		1	-	-	-
	1.2	-	-	-		1.2	-	-	-
T7**	0.2	2268	534	0.41	T7**	0.2	2262	523	0.41
	0.4	2095	597	0.46		0.4	2099	586	0.45
	0.6	1919	660	0.51		0.6	1917	649	0.50
	0.8	1762	704	0.55		0.8	1668	724	0.56
	1	1557	765	0.59		1	-	-	-
	1.2	-	-	-		1.2	-	-	-
T8	0.2	2582	579	0.57	T8	0.2	2579	568	0.56
	0.4	2417	637	0.63		0.4	2424	625	0.62
	0.6	2258	693	0.69		0.6	2260	682	0.68
	0.8	2121	735	0.73		0.8	2060	747	0.74
	1	1944	792	0.78		1	1857	810	0.80
	1.2	1753	844	0.84		1.2	1697	857	0.85
T9	0.2	3622	734	1.35	T9	0.2	3635	720	1.32
	0.4	3487	775	1.42		0.4	3509	762	1.40
	0.6	3369	815	1.50		0.6	3394	802	1.47
	0.8	3278	851	1.56		0.8	3306	841	1.54
	1	3164	893	1.64		1	3184	882	1.62
	1.2	3040	932	1.71		1.2	3070	924	1.69
T10	0.2	3749	753	1.47	T10	0.2	3763	739	1.45
	0.4	3618	793	1.55		0.4	3641	779	1.53
	0.6	3502	832	1.63		0.6	3530	818	1.60
	0.8	3412	867	1.70		0.8	3448	855	1.67
	1	3302	908	1.78		1	3333	894	1.75
	1.2	3184	946	1.85		1.2	3223	935	1.83
	1.4	3015	998	1.95	1.4	3066	977	1.91	

Shaded speed tap - Gas heating airflow.
 **(T1) (T2) and (T6)(T7) are part load only.

7.5 Ton Fan Data • 130 MBH Gas Heat Exchange • Models: DSG0903W, DSG0904W, DSG0907W

Down Flow				
Speed Tap	ESP	CFM	RPM	BHP
T1**	0.2	2304	539	0.43
	0.4	2132	602	0.48
	0.6	1958	664	0.53
	0.8	1803	708	0.57
	1	1602	768	0.61
	1.2	-	-	-
	1.4	-	-	-
	1.6	-	-	-
	1.8	-	-	-
T2**	0.2	2514	569	0.54
	0.4	2347	628	0.59
	0.6	2185	686	0.65
	0.8	2044	728	0.69
	1	1861	786	0.74
	1.2	1665	839	0.79
	1.4	-	-	-
	1.6	-	-	-
	1.8	-	-	-
T3	0.2	3614	732	1.34
	0.4	3478	774	1.41
	0.6	3359	814	1.49
	0.8	3267	850	1.55
	1	3153	893	1.63
	1.2	3028	932	1.70
	1.4	2848	986	1.80
	1.6	2715	1024	1.87
	1.8	2562	1072	1.96
T4	0.2	3847	768	1.58
	0.4	3719	808	1.66
	0.6	3604	845	1.74
	0.8	3514	880	1.81
	1	3406	920	1.89
	1.2	3293	957	1.97
	1.4	3133	1007	2.07
	1.6	3008	1042	2.14
	1.8	2866	1089	2.24
T5	0.2	3957	785	1.71
	0.4	3833	824	1.79
	0.6	3718	860	1.87
	0.8	3627	896	1.95
	1	3521	935	2.03
	1.2	3412	971	2.11
	1.4	3265	1017	2.21
		3144	1052	2.29
	1.8	3008	1097	2.39

Horizontal Flow				
Speed Tap	ESP	CFM	RPM	BHP
T1**	0.2	2299	528	0.42
	0.4	2137	590	0.47
	0.6	1956	653	0.52
	0.8	1713	727	0.58
	1	-	-	-
	1.2	-	-	-
	1.4	-	-	-
	1.6	-	-	-
	1.8	-	-	-
T2**	0.2	2510	558	0.53
	0.4	2354	616	0.58
	0.6	2186	675	0.64
	0.8	1976	742	0.70
	1	1767	807	0.76
	1.2	1603	854	0.81
	1.4	-	-	-
	1.6	-	-	-
	1.8	-	-	-
T3	0.2	3625	719	1.31
	0.4	3499	760	1.39
	0.6	3383	801	1.46
	0.8	3295	840	1.53
	1	3172	881	1.61
	1.2	3058	923	1.68
	1.4	2887	971	1.77
	1.6	2771	1010	1.84
	1.8	2613	1061	1.94
T4	0.2	3847	768	1.58
	0.4	3719	808	1.66
	0.6	3604	845	1.74
	0.8	3514	880	1.81
	1	3406	920	1.89
	1.2	3293	957	1.97
	1.4	3133	1007	2.07
	1.6	3008	1042	2.14
	1.8	2866	1089	2.24
T5	0.2	3973	771	1.68
	0.4	3857	809	1.76
	0.6	3752	845	1.84
	0.8	3673	880	1.91
	1	3568	916	1.99
	1.2	3463	955	2.08
	1.4	3328	991	2.16
		3228	1028	2.24
	1.8	3082	1078	2.35

7.5 Ton Fan Data • 130 MBH Gas Heat Exchange • Models: DSG0903W, DSG0904W, DSG0907W

Down Flow				
Speed Tap	ESP	CFM	RPM	BHP
T6**	0.2	2232	528	0.40
	0.4	2058	593	0.45
	0.6	1879	656	0.49
	0.8	1720	701	0.53
	1	1512	762	0.57
	1.2	-	-	-
	1.4	-	-	-
	1.6	-	-	-
	1.8	-	-	-
T7**	0.2	2682	594	0.63
	0.4	2520	650	0.69
	0.6	2366	704	0.75
	0.8	2235	745	0.79
	1	2066	800	0.85
	1.2	1882	851	0.90
	1.4	1641	918	0.97
	1.6	-	-	-
	1.8	-	-	-
T8	0.2	3090	654	0.90
	0.4	2938	703	0.96
	0.6	2803	751	1.03
	0.8	2694	789	1.08
	1	2553	838	1.15
	1.2	2397	883	1.21
	1.4	2179	946	1.29
	1.6	2029	990	1.36
	1.8	1860	1039	1.42
T9	0.2	3847	768	1.58
	0.4	3719	808	1.66
	0.6	3604	845	1.74
	0.8	3514	880	1.81
	1	3406	920	1.89
	1.2	3293	957	1.97
	1.4	3133	1007	2.07
	1.6	3008	1042	2.14
	1.8	2866	1089	2.24
T10	0.2	3957	785	1.71
	0.4	3833	824	1.79
	0.6	3718	860	1.87
	0.8	3627	896	1.95
	1	3521	935	2.03
	1.2	3412	971	2.11
	1.4	3265	1017	2.21
	1.6	3144	1052	2.29
	1.8	3008	1097	2.39

Horizontal Flow				
Speed Tap	ESP	CFM	RPM	BHP
T6**	0.2	2226	518	0.39
	0.4	2062	581	0.44
	0.6	1877	645	0.49
	0.8	1623	721	0.54
	1	-	-	-
	1.2	-	-	-
	1.4	-	-	-
	1.6	-	-	-
	1.8	-	-	-
T7**	0.2	2680	582	0.62
	0.4	2528	638	0.68
	0.6	2369	693	0.74
	0.8	2184	755	0.80
	1	1990	816	0.87
	1.2	1835	862	0.92
	1.4	1574	964	1.02
	1.6	-	-	-
	1.8	-	-	-
T8	0.2	3092	641	0.88
	0.4	2951	690	0.94
	0.6	2814	738	1.01
	0.8	2680	789	1.08
	1	2520	840	1.15
	1.2	2385	885	1.21
	1.4	2163	961	1.32
	1.6	2008	1002	1.37
	1.8	1852	1048	1.43
T9	0.2	3847	768	1.58
	0.4	3719	808	1.66
	0.6	3604	845	1.74
	0.8	3514	880	1.81
	1	3406	920	1.89
	1.2	3293	957	1.97
	1.4	3133	1007	2.07
	1.6	3008	1042	2.14
	1.8	2866	1089	2.24
T10	0.2	3973	771	1.68
	0.4	3857	809	1.76
	0.6	3752	845	1.84
	0.8	3673	880	1.91
	1	3568	916	1.99
	1.2	3463	955	2.08
	1.4	3328	991	2.16
	1.6	3228	1028	2.24
	1.8	3082	1078	2.35

Shaded speed tap - Gas heating airflow.
 **(T1) (T2) and (T6)(T7) are part load only.

7.5 Ton Fan Data • 180 MBH Gas Heat Exchange • Models: DSG0903D, DSG0904D, DSG0907D

Down Flow				
Speed Tap	ESP	CFM	RPM	BHP
T1**	0.2	1889	504	0.30
	0.4	1815	538	0.32
	0.6	-	-	-
	0.8	-	-	-
T2**	0.2	2136	542	0.41
	0.4	2047	580	0.44
	0.6	1758	672	0.51
	0.8	1532	739	0.56
T3	0.2	3035	682	0.97
	0.4	2904	726	1.04
	0.6	2772	770	1.10
	0.8	2625	819	1.17
T4	0.2	3289	722	1.19
	0.4	3153	766	1.26
	0.6	3049	800	1.32
	0.8	2920	845	1.39
T5	0.2	3404	739	1.29
	0.4	3267	783	1.37
		3173	814	1.42
	0.8	3050	858	1.50
T6**	0.2	1705	475	0.22
	0.4	1645	507	0.24
	0.6	-	-	-
	0.8	-	-	-
T7**	0.2	2136	542	0.25
	0.4	2047	580	0.27
	0.6	1758	672	0.31
	0.8	1532	739	0.35
T8	0.2	2537	605	0.63
	0.4	2426	646	0.67
	0.6	2215	714	0.74
	0.8	2028	773	0.80
T9	0.2	3289	722	1.19
	0.4	3153	766	1.26
	0.6	3049	800	1.32
	0.8	2920	845	1.39
T10	0.2	3404	739	1.29
	0.4	3267	783	1.37
	0.6	3173	814	1.42
	0.8	3050	858	1.50

Horizontal Flow				
Speed Tap	ESP	CFM	RPM	BHP
T1**	0.2	1996	476	0.28
	0.4	1801	545	0.32
	0.6	1613	616	0.36
	0.8	-	-	-
T2**	0.2	2250	512	0.39
	0.4	2068	576	0.43
	0.6	1892	641	0.48
	0.8	1623	722	0.54
T3	0.2	3169	643	0.92
	0.4	3028	690	0.98
	0.6	2890	737	1.05
	0.8	2760	787	1.12
T4	0.2	3427	681	1.12
	0.4	3296	724	1.19
	0.6	3168	766	1.26
	0.8	3063	810	1.33
T5	0.2	3545	698	1.22
	0.4	3417	739	1.29
		3293	780	1.36
	0.8	3197	821	1.44
T6**	0.2	1808	449	0.21
	0.4	1602	523	0.24
	0.6	-	-	-
	0.8	-	-	-
T7**	0.2	2250	512	0.24
	0.4	2068	576	0.27
	0.6	1892	641	0.30
	0.8	1623	722	0.34
T8	0.2	2660	570	0.59
	0.4	2498	626	0.65
	0.6	2340	683	0.71
	0.8	2140	749	0.78
T9	0.2	3427	681	1.12
	0.4	3296	724	1.19
	0.6	3168	766	1.26
	0.8	3063	810	1.33
T10	0.2	3545	698	1.22
	0.4	3417	739	1.29
	0.6	3293	780	1.36
	0.8	3197	821	1.44

Shaded speed tap - Gas heating airflow.
 **(T1) (T2) and (T6)(T7) are part load only.

7.5 Ton Fan Data • 180 MBH Gas Heat Exchange • Models: DSG0903L, DSG0904L, DSG0907L

Down Flow				
Speed Tap	ESP	CFM	RPM	BHP
T1**	0.2	2136	542	0.41
	0.4	2047	580	0.44
	0.6	1758	672	0.51
	0.8	1532	739	0.56
	1	-	-	-
	1.2	-	-	-
T2**	0.2	2374	579	0.53
	0.4	2271	619	0.57
	0.6	2030	697	0.64
	0.8	1827	759	0.70
	1	1656	808	0.74
	1.2	-	-	-
T3	0.2	3404	739	1.29
	0.4	3267	783	1.37
	0.6	3173	814	1.42
	0.8	3050	858	1.50
	1	2934	899	1.57
	1.2	2815	935	1.63
T4	0.2	2628	985	1.72
	0.4	3579	766	1.47
	0.6	3442	810	1.55
	0.8	3359	837	1.60
	1	3245	877	1.68
	1.2	3134	917	1.76
T5	1.2	3022	952	1.82
	1.4	2843	1000	1.91
	0.2	3711	787	1.61
	0.4	3576	829	1.70
	0.6	3497	854	1.75
	0.8	3388	893	1.83
T6**	1	3281	931	1.91
	1.2	3172	965	1.98
	1.4	3002	1011	2.07
	0.2	2273	564	0.48
	0.4	2176	602	0.51
	0.6	1915	686	0.58
T7**	0.8	1703	750	0.64
	1	1525	800	0.68
	1.2	-	-	-
	1.4	-	-	-
	0.2	2664	625	0.71
	0.4	2546	667	0.75
T8	0.6	2358	728	0.82
	0.8	2182	784	0.89
	1	2029	831	0.94
	1.2	1871	876	0.99
	1.4	1674	932	1.06
	0.2	3023	680	0.96
T9	0.4	2893	724	1.03
	0.6	2759	769	1.09
	0.8	2611	818	1.16
	1	2478	862	1.22
	1.2	2342	902	1.28
	1.4	2145	957	1.36
T10	0.2	3579	766	1.47
	0.4	3442	810	1.55
	0.6	3359	837	1.60
	0.8	3245	877	1.68
	1	3134	917	1.76
	1.2	3022	952	1.82
T10	1.4	2843	1000	1.91
	0.2	3711	787	1.61
	0.4	3576	829	1.70
	0.6	3497	854	1.75
	0.8	3388	893	1.83
	1	3281	931	1.91
T10	1.2	3172	965	1.98
	1.4	3002	1011	2.07

Horizontal Flow				
Speed Tap	ESP	CFM	RPM	BHP
T1**	0.2	2250	512	0.39
	0.4	2068	576	0.43
	0.6	1892	641	0.48
	0.8	1623	722	0.54
	1	-	-	-
	1.2	-	-	-
T2**	1.4	-	-	-
	0.2	2493	546	0.50
	0.4	2323	606	0.56
	0.6	2158	665	0.61
	0.8	1932	738	0.68
	1	1720	797	0.73
T3	1.2	1565	854	0.78
	1.4	-	-	-
	0.2	3545	698	1.22
	0.4	3417	739	1.29
	0.6	3293	780	1.36
	0.8	3197	821	1.44
T4	1	3070	865	1.51
	1.2	2940	908	1.59
	1.4	2767	959	1.68
	0.2	3722	724	1.39
	0.4	3600	763	1.46
	0.6	3481	801	1.53
T5	0.8	3395	839	1.61
	1	3278	881	1.69
	1.2	3153	922	1.76
	1.4	2995	965	1.85
	0.2	3856	744	1.52
	0.4	3738	782	1.60
T6**	0.6	3623	818	1.68
	0.8	3540	853	1.75
	1	3430	894	1.83
	1.2	3309	933	1.91
	1.4	3163	972	1.99
	0.2	2390	532	0.45
T7**	0.4	2215	593	0.50
	0.6	2045	655	0.56
	0.8	1802	731	0.62
	1	1580	792	0.67
	1.2	-	-	-
	1.4	-	-	-
T8	0.2	2790	589	0.67
	0.4	2633	642	0.73
	0.6	2480	696	0.79
	0.8	2301	758	0.86
	1	2116	813	0.92
	1.2	1968	865	0.98
T9	1.4	1729	958	1.08
	0.2	3157	642	0.91
	0.4	3016	689	0.98
	0.6	2877	736	1.04
	0.8	2746	786	1.11
	1	2591	836	1.18
T10	1.2	2452	883	1.25
	1.4	2245	954	1.35
	0.2	3722	724	1.39
	0.4	3600	763	1.46
	0.6	3481	801	1.53
	0.8	3395	839	1.61
T10	1	3278	881	1.69
	1.2	3153	922	1.76
	1.4	2995	965	1.85
	0.2	3856	744	1.52
	0.4	3738	782	1.60
	0.6	3623	818	1.68
T10	0.8	3540	853	1.75
	1	3430	894	1.83
	1.2	3309	933	1.91
	1.4	3163	972	1.99

Shaded speed tap - Gas heating airflow.
 **(T1) (T2) and (T6)(T7) are part load only.

7.5 Ton Fan Data • 180 MBH Gas Heat Exchange • Models: DSG0903W, DSG0904W, DSG0907W

Down Flow				
Speed Tap	ESP	CFM	RPM	BHP
T1**	0.2	2307	569	0.49
	0.4	2208	608	0.52
	0.6	1954	690	0.59
	0.8	1745	753	0.65
	1	1569	803	0.69
	1.2	-	-	-
	1.4	-	-	-
	1.6	-	-	-
T2**	0.2	2511	601	0.60
	0.4	2401	642	0.64
	0.6	2186	711	0.71
	0.8	1996	771	0.77
	1	1834	819	0.82
	1.2	1666	865	0.87
	1.4	-	-	-
	1.6	-	-	-
T3	0.2	3564	764	1.43
	0.4	3428	807	1.51
	0.6	3343	835	1.56
	0.8	3229	876	1.63
	1	3118	915	1.71
	1.2	3005	950	1.77
	1.4	2825	998	1.86
	1.6	2705	1034	1.93
T4	0.2	3820	803	1.70
	0.4	3687	844	1.79
	0.6	3608	869	1.84
	0.8	3502	906	1.92
	1	3397	944	2.00
	1.2	3291	977	2.07
	1.4	3129	1021	2.17
	1.6	3015	1055	2.24
T5	0.2	3981	828	1.90
	0.4	3855	867	1.99
	0.6	3769	892	2.05
	0.8	3667	928	2.13
	1	3564	964	2.21
	1.2	3459	997	2.29
	1.4	3313	1036	2.38
	1.6	3202	1070	2.46
1.8	3000	1122	2.58	

Horizontal Flow				
Speed Tap	ESP	CFM	RPM	BHP
T1**	0.2	2425	537	0.46
	0.4	2251	597	0.51
	0.6	2083	658	0.57
	0.8	1845	733	0.63
	1	1627	794	0.68
	1.2	-	-	-
	1.4	-	-	-
	1.6	-	-	-
T2**	0.2	2634	567	0.57
	0.4	2470	623	0.62
	0.6	2311	680	0.68
	0.8	2108	747	0.75
	1	1909	804	0.81
	1.2	1757	859	0.86
	1.4	1505	962	0.96
	1.6	-	-	-
T3	0.2	3707	722	1.35
	0.4	3585	761	1.42
	0.6	3466	800	1.49
	0.8	3379	837	1.56
	1	3261	879	1.64
	1.2	3136	920	1.72
	1.4	2977	965	1.80
	1.6	2834	1016	1.90
T4	0.2	3966	760	1.61
	0.4	3850	797	1.69
	0.6	3737	832	1.76
	0.8	3655	866	1.84
	1	3550	905	1.92
	1.2	3432	944	2.00
	1.4	3295	980	2.08
	1.6	3165	1032	2.19
T5	0.2	4128	785	1.80
	0.4	4015	820	1.88
	0.6	3906	854	1.96
	0.8	3819	887	2.04
	1	3720	924	2.12
	1.2	3606	961	2.21
	1.4	3484	994	2.28
	1.6	3364	1044	2.40
1.8	3246	1075	2.47	

7.5 Ton Fan Data • 180 MBH Gas Heat Exchange • Models: DSG0903W, DSG0904W, DSG0907W

Down Flow				
Speed Tap	ESP	CFM	RPM	BHP
T6**	0.2	2407	585	0.54
	0.4	2302	625	0.58
	0.6	2068	700	0.65
	0.8	1868	762	0.71
	1	1699	811	0.75
	1.2	1524	859	0.80
	1.4	-	-	-
	1.6	-	-	-
	1.8	-	-	-
T7**	0.2	2994	676	0.93
	0.4	2865	720	0.99
	0.6	2727	765	1.05
	0.8	2577	815	1.12
	1	2443	860	1.18
	1.2	2305	900	1.23
	1.4	2107	955	1.31
	1.6	1968	996	1.36
	1.8	1711	1067	1.46
T8	0.2	3505	755	1.37
	0.4	3368	799	1.45
	0.6	3281	827	1.50
	0.8	3163	869	1.57
	1	3051	909	1.65
	1.2	2936	944	1.71
	1.4	2753	993	1.80
	1.6	2632	1030	1.86
	1.8	2365	1099	1.99
T9	0.2	3820	803	1.70
	0.4	3687	844	1.79
	0.6	3608	869	1.84
	0.8	3502	906	1.92
	1	3397	944	2.00
	1.2	3291	977	2.07
	1.4	3129	1021	2.17
	1.6	3015	1055	2.24
	1.8	2781	1115	2.37
T10	0.2	3981	828	1.90
	0.4	3855	867	1.99
	0.6	3769	892	2.05
	0.8	3667	928	2.13
	1	3564	964	2.21
	1.2	3459	997	2.29
	1.4	3313	1036	2.38
	1.6	3202	1070	2.46
	1.8	3000	1122	2.58

Horizontal Flow				
Speed Tap	ESP	CFM	RPM	BHP
T6**	0.2	2527	551	0.51
	0.4	2358	610	0.57
	0.6	2195	669	0.62
	0.8	1974	740	0.69
	1	1765	799	0.74
	1.2	1611	855	0.79
	1.4	-	-	-
	1.6	-	-	-
	1.8	-	-	-
T7**	0.2	3127	637	0.87
	0.4	2985	685	0.94
	0.6	2846	733	1.00
	0.8	2711	784	1.07
	1	2554	834	1.14
	1.2	2414	882	1.21
	1.4	2205	954	1.31
	1.6	2046	987	1.35
	1.8	1853	1046	1.43
T8	0.2	3647	713	1.29
	0.4	3523	753	1.36
	0.6	3402	792	1.43
	0.8	3312	831	1.50
	1	3191	874	1.58
	1.2	3065	916	1.66
	1.4	2900	962	1.74
	1.6	2755	1012	1.83
	1.8	2606	1052	1.90
T9	0.2	3966	760	1.61
	0.4	3850	797	1.69
	0.6	3737	832	1.76
	0.8	3655	866	1.84
	1	3550	905	1.92
	1.2	3432	944	2.00
	1.4	3295	980	2.08
	1.6	3165	1032	2.19
	1.8	3038	1065	2.26
T10	0.2	4128	785	1.80
	0.4	4015	820	1.88
	0.6	3906	854	1.96
	0.8	3819	887	2.04
	1	3720	924	2.12
	1.2	3606	961	2.21
	1.4	3484	994	2.28
	1.6	3364	1044	2.40
	1.8	3246	1075	2.47

Shaded speed tap - Gas heating airflow.
 **(T1) (T2) and (T6)(T7) are part load only.

7.5 Ton Fan Data • 225 MBH Gas Heat Exchange • Models: DSG0903D, DSG0904D, DSG0907D

Down Flow				
Speed Tap	ESP	CFM	RPM	BHP
T1**	0.2	1930	527	0.31
	0.4	1731	594	0.35
	0.6	1551	667	0.39
	0.8	-	-	-
T2**	0.2	2136	561	0.40
	0.4	1958	620	0.45
	0.6	1791	690	0.50
	0.8	1672	751	0.54
T3	0.2	3009	703	0.94
	0.4	2904	738	0.98
	0.6	2786	792	1.05
	0.8	2650	838	1.12
T4	0.2	3208	736	1.10
	0.4	3114	767	1.15
	0.6	3005	818	1.22
	0.8	2870	861	1.28
T5	0.2	3330	756	1.21
	0.4	3242	786	1.25
		3138	834	1.33
	0.8	3004	875	1.40
T6**	0.2	2476	616	0.58
	0.4	2329	664	0.63
	0.6	2183	728	0.69
	0.8	2054	783	0.74
T7**	0.2	3174	730	0.69
	0.4	3078	762	0.72
	0.6	2968	813	0.77
	0.8	2833	857	0.81
T8	0.2	3735	822	1.63
	0.4	3659	851	1.69
	0.6	3568	892	1.77
	0.8	3447	928	1.84
T9	0.2	3208	736	1.10
	0.4	3114	767	1.15
	0.6	3005	818	1.22
	0.8	2870	861	1.28
T10	0.2	3330	756	1.21
	0.4	3242	786	1.25
	0.6	3138	834	1.33
	0.8	3004	875	1.40

Horizontal Flow				
Speed Tap	ESP	CFM	RPM	BHP
T1**	0.2	1991	485	0.29
	0.4	1791	572	0.34
	0.6	1568	650	0.38
	0.8	-	-	-
T2**	0.2	2210	515	0.37
	0.4	2026	594	0.43
	0.6	1821	667	0.48
	0.8	1724	734	0.53
T3	0.2	3130	643	0.86
	0.4	3002	694	0.92
	0.6	2865	748	1.00
	0.8	2742	798	1.06
T4	0.2	3338	673	1.00
	0.4	3220	718	1.07
	0.6	3095	769	1.15
	0.8	2970	815	1.22
T5	0.2	3464	691	1.10
	0.4	3351	734	1.17
		3233	783	1.25
	0.8	3108	827	1.32
T6**	0.2	2570	564	0.53
	0.4	2409	631	0.59
	0.6	2234	697	0.66
	0.8	2124	756	0.71
T7**	0.2	3302	668	0.63
	0.4	3182	714	0.67
	0.6	3055	765	0.72
	0.8	2931	812	0.77
T8	0.2	3882	754	1.50
	0.4	3781	791	1.57
	0.6	3676	834	1.66
	0.8	3560	872	1.73
T9	0.2	3338	673	1.00
	0.4	3220	718	1.07
	0.6	3095	769	1.15
	0.8	2970	815	1.22
T10	0.2	3464	691	1.10
	0.4	3351	734	1.17
	0.6	3233	783	1.25
	0.8	3108	827	1.32

Shaded speed tap - Gas heating airflow.
 **(T1) (T2) and (T6)(T7) are part load only.

7.5 Ton Fan Data • 225 MBH Gas Heat Exchange • Models: DSG0903L, DSG0904L, DSG0907L

Down Flow					Horizontal Flow				
Speed Tap	ESP	CFM	RPM	BHP	Speed Tap	ESP	CFM	RPM	BHP
T1**	0.2	2136	561	0.40	T1**	0.2	2210	515	0.37
	0.4	1958	620	0.44		0.4	2026	594	0.42
	0.6	1791	690	0.49		0.6	1821	667	0.47
	0.8	1672	751	0.53		0.8	1724	734	0.52
	1	-	-	-		1	1522	795	0.56
	1.2	-	-	-		1.2	-	-	-
T2**	0.2	2349	595	0.50	T2**	0.2	2435	546	0.46
	0.4	2191	648	0.55		0.4	2266	617	0.52
	0.6	2037	714	0.60		0.6	2080	685	0.58
	0.8	1911	771	0.65		0.8	1975	748	0.63
	1	1731	823	0.69		1	1788	806	0.68
	1.2	-	-	-		1.2	1595	867	0.73
T3	0.2	3324	755	1.18	T3	0.2	3459	691	1.08
	0.4	3236	785	1.23		0.4	3345	733	1.15
	0.6	3132	833	1.30		0.6	3226	782	1.22
	0.8	2999	875	1.37		0.8	3102	826	1.29
	1	2869	915	1.43		1	2980	872	1.36
	1.2	2692	959	1.50		1.2	2850	921	1.44
T4	0.2	3596	799	1.45	T4	0.2	3585	709	1.28
	0.4	3517	828	1.50		0.4	3476	750	1.36
	0.6	3423	871	1.58		0.6	3363	797	1.44
	0.8	3295	909	1.65		0.8	3239	839	1.52
	1	3178	947	1.71		1	3123	883	1.60
	1.2	3017	987	1.79		1.2	3001	930	1.68
T5	0.2	3735	822	1.60	T5	0.2	3882	754	1.47
	0.4	3659	851	1.66		0.4	3781	791	1.54
	0.6	3568	892	1.74		0.6	3676	834	1.63
	0.8	3447	928	1.81		0.8	3560	872	1.70
	1	3334	965	1.88		1	3457	912	1.78
	1.2	3181	1003	1.96		1.2	3351	955	1.86
T6**	0.2	2746	660	0.74	T6**	0.2	2854	604	0.67
	0.4	2621	701	0.78		0.4	2711	662	0.74
	0.6	2490	760	0.85		0.6	2556	722	0.80
	0.8	2356	810	0.90		0.8	2438	776	0.86
	1	2198	857	0.95		1	2280	830	0.92
	1.2	1986	908	1.01		1.2	2113	886	0.99
T7**	0.2	3446	775	1.29	T7**	0.2	3585	709	1.18
	0.4	3363	804	1.34		0.4	3476	750	1.25
	0.6	3264	850	1.42		0.6	3363	797	1.33
	0.8	3132	889	1.49		0.8	3239	839	1.40
	1	3008	929	1.55		1	3123	883	1.48
	1.2	2838	971	1.62		1.2	3001	930	1.55
T8	0.2	3983	862	1.92	T8	0.2	4135	794	1.77
	0.4	3905	896	2.00		0.4	4034	830	1.85
	0.6	3818	932	2.08		0.6	3930	871	1.94
	0.8	3712	966	2.15		0.8	3828	906	2.02
	1	3608	1000	2.23		1	3732	943	2.10
	1.2	3468	1036	2.31		1.2	3639	982	2.19
T9	0.2	3596	799	1.45	T9	0.2	3585	709	1.28
	0.4	3517	828	1.50		0.4	3476	750	1.36
	0.6	3423	871	1.58		0.6	3363	797	1.44
	0.8	3295	909	1.65		0.8	3239	839	1.52
	1	3178	947	1.71		1	3123	883	1.60
	1.2	3017	987	1.79		1.2	3001	930	1.68
T10	0.2	3735	822	1.60	T10	0.2	3882	754	1.47
	0.4	3659	851	1.66		0.4	3781	791	1.54
	0.6	3568	892	1.74		0.6	3676	834	1.63
	0.8	3447	928	1.81		0.8	3560	872	1.70
	1	3334	965	1.88		1	3457	912	1.78
	1.2	3181	1003	1.96		1.2	3351	955	1.86
	1.4	3020	1044	2.03	1.4	3216	998	1.95	

Shaded speed tap - Gas heating airflow.
 **(T1) (T2) and (T6)(T7) are part load only.

7.5 Ton Fan Data • 225 MBH Gas Heat Exchange • Models: DSG0903W, DSG0904W, DSG0907W

Down Flow				
Speed Tap	ESP	CFM	RPM	BHP
T1**	0.2	2284	585	0.47
	0.4	2120	639	0.51
	0.6	1962	706	0.57
	0.8	1838	765	0.61
	1	1655	817	0.66
	1.2	-	-	-
	1.4	-	-	-
	1.6	-	-	-
	1.8	-	-	-
T2**	0.2	2483	617	0.58
	0.4	2337	665	0.62
	0.6	2191	729	0.68
	0.8	2062	784	0.73
	1	1890	834	0.78
	1.2	1662	887	0.83
	1.4	-	-	-
	1.6	-	-	-
	1.8	-	-	-
T3	0.2	3581	797	1.43
	0.4	3502	826	1.48
	0.6	3407	869	1.56
	0.8	3280	907	1.63
	1	3161	945	1.70
	1.2	3000	986	1.77
	1.4	2829	1027	1.85
	1.6	2778	1070	1.92
	1.8	2637	1115	2.00
T4	0.2	3766	827	1.64
	0.4	3690	857	1.70
	0.6	3600	897	1.78
	0.8	3480	932	1.85
	1	3369	969	1.92
	1.2	3218	1007	2.00
	1.4	3059	1047	2.07
	1.6	3011	1087	2.15
	1.8	2882	1131	2.24
T5	0.2	3856	841	1.75
	0.4	3780	873	1.81
	0.6	3691	911	1.89
	0.8	3577	946	1.97
	1	3468	981	2.04
	1.2	3322	1019	2.12
	1.4	3170	1057	2.20
	1.6	3126	1096	2.28
	1.8	3004	1139	2.37

Horizontal Flow				
Speed Tap	ESP	CFM	RPM	BHP
T1**	0.2	2366	536	0.43
	0.4	2193	610	0.49
	0.6	2001	680	0.55
	0.8	1898	743	0.60
	1	1707	803	0.64
	1.2	1509	864	0.694
	1.4	-	-	-
	1.6	-	-	-
	1.8	-	-	-
T2**	0.2	2577	565	0.53
	0.4	2417	632	0.59
	0.6	2242	697	0.65
	0.8	2132	757	0.71
	1	1955	814	0.76
	1.2	1771	873	0.81
	1.4	1604	934	0.87
	1.6	-	-	-
	1.8	-	-	-
T3	0.2	3724	730	1.31
	0.4	3620	768	1.38
	0.6	3511	813	1.46
	0.8	3390	853	1.53
	1	3280	896	1.61
	1.2	3166	941	1.69
	1.4	3022	987	1.77
	1.6	2839	1046	1.88
	1.8	2699	1092	1.96
T4	0.2	3914	759	1.50
	0.4	3813	795	1.58
	0.6	3709	838	1.66
	0.8	3594	875	1.73
	1	3492	916	1.81
	1.2	3388	958	1.90
	1.4	3254	1001	1.98
	1.6	3085	1057	2.09
	1.8	2953	1102	2.18
T5	0.2	4006	774	1.61
	0.4	3905	809	1.68
	0.6	3802	851	1.77
	0.8	3692	887	1.84
	1	3592	926	1.93
	1.2	3494	967	2.01
	1.4	3366	1009	2.10
	1.6	3206	1062	2.21
	1.8	3080	1107	2.30

7.5 Ton Fan Data • 225 MBH Gas Heat Exchange • Models: DSG0903W, DSG0904W, DSG0907W

Down Flow				
Speed Tap	ESP	CFM	RPM	BHP
T6**	0.2	2874	681	0.82
	0.4	2759	719	0.87
	0.6	2634	775	0.94
	0.8	2499	824	0.99
	1	2348	869	1.05
	1.2	2144	918	1.11
	1.4	1938	965	1.16
	1.6	1895	1015	1.22
T7**	1.8	1739	1059	1.28
	0.2	3547	791	1.39
	0.4	3467	820	1.45
	0.6	3371	864	1.52
	0.8	3242	902	1.59
	1	3123	941	1.66
	1.2	2959	982	1.73
	1.4	2786	1024	1.81
T8	1.6	2735	1067	1.88
	1.8	2592	1112	1.96
	0.2	4057	874	2.03
	0.4	3976	911	2.11
	0.6	3889	945	2.19
	0.8	3790	978	2.27
	1	3687	1012	2.35
	1.2	3552	1047	2.43
T9	1.4	3416	1083	2.51
	1.6	3383	1119	2.60
	1.8	3285	1157	2.69
	0.2	3766	827	1.64
	0.4	3690	857	1.70
	0.6	3600	897	1.78
	0.8	3480	932	1.85
	1	3369	969	1.92
T10	1.2	3218	1007	2.00
	1.4	3059	1047	2.07
	1.6	3011	1087	2.15
	1.8	2882	1131	2.24
	0.2	3856	841	1.75
	0.4	3780	873	1.81
	0.6	3691	911	1.89
	0.8	3577	946	1.97
T10	1	3468	981	2.04
	1.2	3322	1019	2.12
	1.4	3170	1057	2.20
	1.6	3126	1096	2.28
	1.8	3004	1139	2.37

Horizontal Flow				
Speed Tap	ESP	CFM	RPM	BHP
T6**	0.2	2988	623	0.75
	0.4	2853	677	0.82
	0.6	2707	734	0.89
	0.8	2586	786	0.95
	1	2437	838	1.01
	1.2	2279	893	1.08
	1.4	2114	948	1.14
	1.6	1922	1008	1.22
T7**	1.8	1762	1052	1.27
	0.2	3689	725	1.28
	0.4	3583	764	1.35
	0.6	3474	809	1.43
	0.8	3352	849	1.50
	1	3241	893	1.57
	1.2	3125	938	1.66
	1.4	2979	985	1.74
T8	1.6	2794	1044	1.84
	1.8	2652	1090	1.92
	0.2	4209	807	1.87
	0.4	4106	843	1.96
	0.6	4001	883	2.05
	0.8	3906	917	2.13
	1	3810	954	2.21
	1.2	3722	991	2.30
T9	1.4	3611	1029	2.39
	1.6	3482	1075	2.50
	1.8	3369	1116	2.59
	0.2	3914	759	1.50
	0.4	3813	795	1.58
	0.6	3709	838	1.66
	0.8	3594	875	1.73
	1	3492	916	1.81
T10	1.2	3388	958	1.90
	1.4	3254	1001	1.98
	1.6	3085	1057	2.09
	1.8	2953	1102	2.18
	0.2	4006	774	1.61
	0.4	3905	809	1.68
	0.6	3802	851	1.77
	0.8	3692	887	1.84
T10	1	3592	926	1.93
	1.2	3494	967	2.01
	1.4	3366	1009	2.10
	1.6	3206	1062	2.21
	1.8	3080	1107	2.30

Shaded speed tap - Gas heating airflow.
 **(T1) (T2) and (T6)(T7) are part load only.

8.5 Ton Fan Data • 130 MBH Gas Heat Exchange • Models: DSG1023D, DSG1024D, DSG1027D

Down Flow				
Speed Tap	ESP	CFM	RPM	BHP
T1**	0.2	2071	505	0.33
	0.4	1893	573	0.37
	0.6	1705	639	0.41
	0.8	-	-	-
T2**	0.2	2268	533	0.41
	0.4	2095	597	0.46
	0.6	1918	660	0.51
	0.8	1761	704	0.55
T3	0.2	3305	686	1.06
	0.4	3160	732	1.13
	0.6	3034	776	1.20
	0.8	2934	812	1.26
T4	0.2	3652	738	1.37
	0.4	3518	780	1.45
	0.6	3401	819	1.53
	0.8	3309	855	1.59
T5	0.2	3740	751	1.46
	0.4	3608	792	1.54
	0.6	3492	830	1.62
	0.8	3402	866	1.69
T6**	0.2	1860	475	0.24
	0.4	-	-	-
	0.6	-	-	-
	0.8	-	-	-
T7**	0.2	1974	491	0.25
	0.4	1794	561	0.29
	0.6	-	-	-
	0.8	-	-	-
T8	0.2	2303	539	0.43
	0.4	2131	602	0.48
	0.6	1957	663	0.53
	0.8	1802	707	0.57
T9	0.2	3652	738	1.37
	0.4	3518	780	1.45
	0.6	3401	819	1.53
	0.8	3309	855	1.59
T10	0.2	3740	751	1.46
	0.4	3608	792	1.54
	0.6	3492	830	1.62
	0.8	3402	866	1.69

Horizontal Flow				
Speed Tap	ESP	CFM	RPM	BHP
T1**	0.2	2063	496	0.32
	0.4	1895	561	0.36
	0.6	1700	628	0.41
	0.8	-	-	-
T2**	0.2	2262	523	0.41
	0.4	2099	586	0.45
	0.6	1917	649	0.50
	0.8	-	-	-
T3	0.2	3314	673	1.04
	0.4	3179	719	1.11
	0.6	3052	764	1.18
	0.8	2940	809	1.25
T4	0.2	3665	725	1.35
	0.4	3540	766	1.43
	0.6	3426	806	1.50
	0.8	3340	844	1.57
T5	0.2	3753	738	1.44
	0.4	3631	778	1.52
	0.6	3520	817	1.59
	0.8	3437	854	1.66
T6**	0.2	1848	466	0.24
	0.4	-	-	-
	0.6	-	-	-
	0.8	-	-	-
T7**	0.2	1964	482	0.25
	0.4	1794	549	0.28
	0.6	-	-	-
	0.8	-	-	-
T8	0.2	2299	528	0.42
	0.4	2137	590	0.47
	0.6	1956	653	0.52
	0.8	1713	727	0.58
T9	0.2	3665	725	1.35
	0.4	3540	766	1.43
	0.6	3426	806	1.50
	0.8	3340	844	1.57
T10	0.2	3753	738	1.44
	0.4	3631	778	1.52
	0.6	3520	817	1.59
	0.8	3437	854	1.66

Shaded speed tap - Gas heating airflow.
 **(T1) (T2) and (T6)(T7) are part load only.

8.5 Ton Fan Data • 130 MBH Gas Heat Exchange • Models: DSG1023L, DSG1024L, DSG1027L

Down Flow					Horizontal Flow				
Speed Tap	ESP	CFM	RPM	BHP	Speed Tap	ESP	CFM	RPM	BHP
T1**	0.2	2246	530	0.40	T1**	0.2	2241	520	0.39
	0.4	2073	594	0.45		0.4	2077	583	0.44
	0.6	1895	657	0.49		0.6	1893	647	0.49
	0.8	1736	702	0.53		0.8	-	-	-
	1	-	-	-		1	-	-	-
	1.2	-	-	-		1.2	-	-	-
T2**	0.2	2457	561	0.50	T2**	0.2	2455	550	0.49
	0.4	2289	621	0.55		0.4	2297	610	0.54
	0.6	2124	680	0.61		0.6	2126	669	0.60
	0.8	1980	722	0.64		0.8	1907	738	0.66
	1	1792	781	0.70		1	-	-	-
	1.2	-	-	-		1.2	-	-	-
T3	0.2	3582	728	1.28	T3	0.2	3594	714	1.26
	0.4	3446	770	1.36		0.4	3467	756	1.33
	0.6	3327	810	1.43		0.6	3351	797	1.41
	0.8	3235	846	1.49		0.8	3261	837	1.48
	1	3120	889	1.57		1	3136	878	1.55
	1.2	2994	928	1.64		1.2	3021	921	1.62
T4	0.2	3957	785	1.68	T4	0.2	3979	762	1.63
	0.4	3833	824	1.76		0.4	3863	799	1.71
	0.6	3718	860	1.84		0.6	3751	834	1.78
	0.8	3627	896	1.91		0.8	3669	868	1.85
	1	3521	935	2.00		1	3564	907	1.94
	1.2	3412	971	2.07		1.2	3447	945	2.02
T5	0.2	4082	805	1.83	T5	0.2	4108	782	1.78
	0.4	3962	843	1.92		0.4	3994	817	1.86
	0.6	3847	878	2.00		0.6	3885	851	1.93
	0.8	3753	914	2.08		0.8	3799	884	2.01
	1	3646	952	2.16		1	3699	922	2.10
	1.2	3541	987	2.24		1.2	3585	959	2.18
T6**	0.2	1936	486	0.27	T6**	0.2	1926	477	0.27
	0.4	1755	556	0.31		0.4	1754	545	0.30
	0.6	-	-	-		0.6	-	-	-
	0.8	-	-	-		0.8	-	-	-
	1	-	-	-		1	-	-	-
	1.2	-	-	-		1.2	-	-	-
T7**	0.2	2268	533	0.41	T7**	0.2	2262	523	0.40
	0.4	2095	597	0.46		0.4	2099	586	0.45
	0.6	1918	660	0.51		0.6	1917	649	0.50
	0.8	1761	704	0.54		0.8	-	-	-
	1	-	-	-		1	-	-	-
	1.2	-	-	-		1.2	-	-	-
T8	0.2	2580	579	0.56	T8	0.2	2580	568	0.55
	0.4	2415	637	0.62		0.4	2424	625	0.61
	0.6	2256	693	0.68		0.6	2260	682	0.66
	0.8	2120	735	0.72		0.8	2060	747	0.73
	1	1943	791	0.77		1	1857	810	0.79
	1.2	1752	843	0.82		1.2	1697	857	0.84
T9	0.2	3957	785	1.68	T9	0.2	3979	762	1.63
	0.4	3833	824	1.76		0.4	3863	799	1.71
	0.6	3718	860	1.84		0.6	3751	834	1.78
	0.8	3627	896	1.91		0.8	3669	868	1.85
	1	3521	935	2.00		1	3564	907	1.94
	1.2	3412	971	2.07		1.2	3447	945	2.02
T10	0.2	4082	805	1.83	T10	0.2	4108	782	1.78
	0.4	3962	843	1.92		0.4	3994	817	1.86
	0.6	3847	878	2.00		0.6	3885	851	1.93
	0.8	3753	914	2.08		0.8	3799	884	2.01
	1	3646	952	2.16		1	3699	922	2.10
	1.2	3541	987	2.24		1.2	3585	959	2.18
1.4	3409	1030	2.34	1.4	3460	992	2.26		

Shaded speed tap - Gas heating airflow.
 **(T1) (T2) and (T6)(T7) are part load only.

8.5 Ton Fan Data • 130 MBH Gas Heat Exchange • Models: DSG1023W, DSG1024W, DSG1027W

Down Flow				
Speed Tap	ESP	CFM	RPM	BHP
T1**	0.2	2388	551	0.47
	0.4	2218	612	0.52
	0.6	2049	672	0.57
	0.8	1900	716	0.60
	1	1706	775	0.65
	1.2	-	-	-
	1.4	-	-	-
	1.6	-	-	-
T2**	0.2	2593	581	0.57
	0.4	2429	638	0.63
	0.6	2271	694	0.68
	0.8	2135	736	0.72
	1	1959	792	0.78
	1.2	1770	844	0.83
	1.4	-	-	-
	1.6	-	-	-
T3	0.2	3787	759	1.49
	0.4	3657	799	1.56
	0.6	3541	837	1.64
	0.8	3451	872	1.71
	1	3343	913	1.79
	1.2	3227	950	1.86
	1.4	3061	1001	1.96
	1.6	2933	1037	2.03
T4	0.2	4179	820	1.96
	0.4	4063	858	2.05
	0.6	3946	893	2.13
	0.8	3848	930	2.22
	1	3740	966	2.31
	1.2	3638	1001	2.39
	1.4	3519	1041	2.49
	1.6	3409	1074	2.57
T5	0.2	4271	835	2.09
	0.4	4158	872	2.19
	0.6	4038	907	2.27
	0.8	3935	945	2.37
	1	3824	980	2.46
	1.2	3724	1015	2.54
	1.4	3618	1051	2.63
	1.6	3513	1084	2.72

Horizontal Flow				
Speed Tap	ESP	CFM	RPM	BHP
T1**	0.2	2384	540	0.46
	0.4	2224	601	0.51
	0.6	2049	662	0.56
	0.8	1820	733	0.62
	1	-	-	-
	1.2	-	-	-
	1.4	-	-	-
	1.6	-	-	-
T2**	0.2	2593	570	0.56
	0.4	2438	627	0.62
	0.6	2275	684	0.67
	0.8	2077	748	0.74
	1	1875	811	0.80
	1.2	1715	858	0.84
	1.4	-	-	-
	1.6	-	-	-
T3	0.2	3801	745	1.46
	0.4	3680	784	1.54
	0.6	3570	823	1.61
	0.8	3489	859	1.68
	1	3376	897	1.76
	1.2	3267	939	1.84
	1.4	3114	979	1.92
	1.6	3008	1017	1.99
T4	0.2	4197	806	1.93
	0.4	4088	841	2.01
	0.6	3985	876	2.09
	0.8	3899	910	2.17
	1	3802	944	2.26
	1.2	3701	981	2.35
	1.4	3589	1014	2.42
	1.6	3493	1049	2.51
T5	0.2	4288	821	2.06
	0.4	4183	855	2.14
	0.6	4080	890	2.23
	0.8	3987	924	2.32
	1	3892	957	2.40
	1.2	3791	994	2.49
	1.4	3689	1026	2.57
	1.6	3593	1061	2.66

8.5 Ton Fan Data • 130 MBH Gas Heat Exchange • Models: DSG1023W, DSG1024W, DSG1027W

Down Flow				
Speed Tap	ESP	CFM	RPM	BHP
T6**	0.2	2232	528	0.39
	0.4	2058	593	0.44
	0.6	1879	656	0.49
	0.8	1720	701	0.52
	1	-	-	-
	1.2	-	-	-
	1.4	-	-	-
	1.6	-	-	-
T7**	0.2	2680	593	0.62
	0.4	2517	649	0.68
	0.6	2364	704	0.73
	0.8	2234	745	0.78
	1	2064	800	0.84
	1.2	1881	850	0.89
	1.4	-	-	-
	1.6	-	-	-
T8	0.2	3086	653	0.88
	0.4	2935	702	0.95
	0.6	2800	750	1.01
	0.8	2692	788	1.06
	1	2552	837	1.13
	1.2	2396	882	1.19
	1.4	2176	945	1.27
	1.6	2025	990	1.33
T9	0.2	4179	820	1.96
	0.4	4063	858	2.05
	0.6	3946	893	2.13
	0.8	3848	930	2.22
	1	3740	966	2.31
	1.2	3638	1001	2.39
	1.4	3519	1041	2.49
	1.6	3409	1074	2.57
T10	0.2	4271	835	2.09
	0.4	4158	872	2.19
	0.6	4038	907	2.27
	0.8	3935	945	2.37
	1	3824	980	2.46
	1.2	3724	1015	2.54
	1.4	3618	1051	2.63
	1.6	3513	1084	2.72

Horizontal Flow				
Speed Tap	ESP	CFM	RPM	BHP
T6**	0.2	2226	518	0.38
	0.4	2062	581	0.43
	0.6	1877	645	0.48
	0.8	-	-	-
	1	-	-	-
	1.2	-	-	-
	1.4	-	-	-
	1.6	-	-	-
T7**	0.2	2680	582	0.61
	0.4	2528	638	0.67
	0.6	2369	693	0.72
	0.8	2184	755	0.79
	1	1990	816	0.85
	1.2	1835	862	0.90
	1.4	-	-	-
	1.6	-	-	-
T8	0.2	3092	641	0.86
	0.4	2951	690	0.93
	0.6	2814	738	0.99
	0.8	2680	789	1.06
	1	2520	840	1.13
	1.2	2385	885	1.19
	1.4	2163	961	1.29
	1.6	2008	1002	1.35
T9	0.2	4197	806	1.93
	0.4	4088	841	2.01
	0.6	3985	876	2.09
	0.8	3899	910	2.17
	1	3802	944	2.26
	1.2	3701	981	2.35
	1.4	3589	1014	2.42
	1.6	3493	1049	2.51
T10	0.2	4288	821	2.06
	0.4	4183	855	2.14
	0.6	4080	890	2.23
	0.8	3987	924	2.32
	1	3892	957	2.40
	1.2	3791	994	2.49
	1.4	3689	1026	2.57
	1.6	3593	1061	2.66

Shaded speed tap - Gas heating airflow.
 **(T1) (T2) and (T6)(T7) are part load only.

8.5 Ton Fan Data • 180 MBH Gas Heat Exchange • Models: DSG1023D, DSG1024D, DSG1027D

Down Flow				
Speed Tap	ESP	CFM	RPM	BHP
T1**	0.2	1996	520	0.34
	0.4	1915	556	0.37
	0.6	-	-	-
	0.8	-	-	-
T2**	0.2	2239	558	0.46
	0.4	2144	597	0.49
	0.6	1876	683	0.56
	0.8	-	-	-
T3	0.2	3257	717	1.16
	0.4	3122	761	1.23
	0.6	3014	796	1.29
	0.8	2883	842	1.36
T4	0.2	3618	772	1.51
	0.4	3481	815	1.59
	0.6	3399	842	1.64
	0.8	3287	882	1.72
T5	0.2	3721	788	1.62
	0.4	3586	830	1.71
	0.6	3506	855	1.76
	0.8	3398	894	1.84
T6**	0.2	1705	475	0.22
	0.4	-	-	-
	0.6	-	-	-
	0.8	-	-	-
T7**	0.2	2136	542	0.25
	0.4	2047	580	0.27
	0.6	1758	672	0.31
	0.8	-	-	-
T8	0.2	2537	605	0.63
	0.4	2426	646	0.67
	0.6	2215	714	0.74
	0.8	2028	773	0.80
T9	0.2	3618	772	1.51
	0.4	3481	815	1.59
	0.6	3399	842	1.64
	0.8	3287	882	1.72
T10	0.2	3721	788	1.62
	0.4	3586	830	1.71
	0.6	3506	855	1.76
	0.8	3398	894	1.84

Horizontal Flow				
Speed Tap	ESP	CFM	RPM	BHP
T1**	0.2	2106	492	0.32
	0.4	1917	558	0.37
	0.6	1734	627	0.41
	0.8	-	-	-
T2**	0.2	2355	527	0.43
	0.4	2178	589	0.49
	0.6	2007	651	0.54
	0.8	1758	729	0.60
T3	0.2	3395	676	1.09
	0.4	3263	720	1.16
	0.6	3133	763	1.23
	0.8	3025	807	1.30
T4	0.2	3761	730	1.43
	0.4	3640	769	1.50
	0.6	3523	806	1.57
	0.8	3438	843	1.65
T5	0.2	3866	745	1.53
	0.4	3747	783	1.61
	0.6	3632	819	1.69
	0.8	3550	854	1.76
T6**	0.2	1808	449	0.21
	0.4	-	-	-
	0.6	-	-	-
	0.8	-	-	-
T7**	0.2	2250	512	0.24
	0.4	2068	576	0.27
	0.6	1892	641	0.30
	0.8	-	-	-
T8	0.2	2660	570	0.59
	0.4	2498	626	0.65
	0.6	2340	683	0.71
	0.8	2140	749	0.78
T9	0.2	3761	730	1.43
	0.4	3640	769	1.50
	0.6	3523	806	1.57
	0.8	3438	843	1.65
T10	0.2	3866	745	1.53
	0.4	3747	783	1.61
	0.6	3632	819	1.69
	0.8	3550	854	1.76

Shaded speed tap - Gas heating airflow.
 **(T1) (T2) and (T6)(T7) are part load only.

8.5 Ton Fan Data • 180 MBH Gas Heat Exchange • Models: DSG1023L, DSG1024L, DSG1027L

Down Flow					Horizontal Flow				
Speed Tap	ESP	CFM	RPM	BHP	Speed Tap	ESP	CFM	RPM	BHP
T1**	0.2	2239	558	0.45	T1**	0.2	2355	527	0.43
	0.4	2144	597	0.48		0.4	2178	589	0.48
	0.6	1876	683	0.55		0.6	2007	651	0.53
	0.8	-	-	-		0.8	1758	729	0.59
	1	-	-	-		1	-	-	-
	1.2	-	-	-		1.2	-	-	-
T2**	0.2	2459	593	0.57	T2**	0.2	2581	559	0.54
	0.4	2352	633	0.61		0.4	2414	616	0.60
	0.6	2127	706	0.68		0.6	2253	674	0.65
	0.8	1932	766	0.74		0.8	2041	743	0.72
	1	1767	815	0.79		1	1838	802	0.77
	1.2	-	-	-		1.2	-	-	-
T3	0.2	3560	763	1.42	T3	0.2	3702	721	1.34
	0.4	3423	807	1.50		0.4	3580	761	1.42
	0.6	3338	834	1.55		0.6	3460	799	1.49
	0.8	3223	875	1.63		0.8	3373	836	1.56
	1	3112	915	1.70		1	3255	879	1.64
	1.2	2999	950	1.77		1.2	3130	920	1.71
T4	0.2	2819	998	1.86	T4	0.2	2970	964	1.79
	0.4	3919	818	1.82		0.4	4066	775	1.73
	0.6	3790	858	1.91		0.6	3952	811	1.81
	0.8	3708	883	1.97		0.8	3842	845	1.88
	1	3605	919	2.05		1	3757	878	1.96
	1.2	3501	956	2.13		1.2	3656	917	2.04
T5	0.2	3395	989	2.20	T5	0.2	3540	954	2.13
	0.4	3243	1030	2.30		0.4	3412	988	2.20
	0.6	4061	840	2.01		0.6	4209	797	1.91
	0.8	3939	877	2.10		0.8	4097	832	1.99
	1	3848	904	2.16		1	3989	865	2.07
	1.2	3746	939	2.24		1.2	3897	898	2.15
T6**	0.2	3642	974	2.33	T6**	0.2	3799	935	2.23
	0.4	3537	1007	2.41		0.4	3689	971	2.32
	0.6	3402	1045	2.50		0.6	3573	1003	2.40
	0.8	2273	564	0.47		0.8	2390	532	0.44
	1	2176	602	0.50		1	2215	593	0.50
	1.2	1915	686	0.57		1.2	2045	655	0.55
T7**	0.2	1703	750	0.63	T7**	0.2	1802	731	0.61
	0.4	-	-	-		0.4	-	-	-
	0.6	-	-	-		0.6	-	-	-
	0.8	-	-	-		0.8	-	-	-
	1	-	-	-		1	-	-	-
	1.2	-	-	-		1.2	-	-	-
T8	0.2	2664	625	0.70	T8	0.2	2790	589	0.66
	0.4	2546	667	0.74		0.4	2633	642	0.72
	0.6	2358	728	0.81		0.6	2480	696	0.78
	0.8	2182	784	0.87		0.8	2301	758	0.84
	1	2029	831	0.93		1	2116	813	0.91
	1.2	1871	876	0.98		1.2	1968	865	0.96
T9	0.2	1445	500	0.40	T9	0.2	1525	465	0.37
	0.4	1393	477	0.38		0.4	1466	437	0.35
	0.6	1348	456	0.36		0.6	1412	411	0.33
	0.8	1308	433	0.34		0.8	1362	387	0.31
	1	1272	411	0.32		1	1316	365	0.29
	1.2	1239	390	0.30		1.2	1273	345	0.27
T10	0.2	3023	680	0.95	T10	0.2	3157	642	0.89
	0.4	2893	724	1.01		0.4	3016	689	0.96
	0.6	2759	769	1.07		0.6	2877	736	1.02
	0.8	2611	818	1.14		0.8	2746	786	1.09
	1	2478	862	1.20		1	2591	836	1.16
	1.2	2342	902	1.26		1.2	2452	883	1.23
T10	0.2	2145	957	1.33	T10	0.2	2245	954	1.33
	0.4	3919	818	1.82		0.4	4066	775	1.73
	0.6	3790	858	1.91		0.6	3952	811	1.81
	0.8	3708	883	1.97		0.8	3842	845	1.88
	1	3605	919	2.05		1	3757	878	1.96
	1.2	3501	956	2.13		1.2	3656	917	2.04
T10	0.2	3395	989	2.20	T10	0.2	3540	954	2.13
	0.4	3243	1030	2.30		0.4	3412	988	2.20
	0.6	4061	840	2.01		0.6	4209	797	1.91
	0.8	3939	877	2.10		0.8	4097	832	1.99
	1	3848	904	2.16		1	3989	865	2.07
	1.2	3746	939	2.24		1.2	3897	898	2.15
T10	0.2	3642	974	2.33	T10	0.2	3799	935	2.23
	0.4	3537	1007	2.41		0.4	3689	971	2.32
	0.6	3402	1045	2.50		0.6	3573	1003	2.40
	0.8	2273	564	0.47		0.8	2390	532	0.44
	1	2176	602	0.50		1	2215	593	0.50
	1.2	1915	686	0.57		1.2	2045	655	0.55

Shaded speed tap - Gas heating airflow.
 **(T1) (T2) and (T6)(T7) are part load only.

8.5 Ton Fan Data • 180 MBH Gas Heat Exchange • Models: DSG1023W, DSG1024W, DSG1027W

Down Flow				
Speed Tap	ESP	CFM	RPM	BHP
T1**	0.2	2394	582	0.54
	0.4	2290	622	0.57
	0.6	2053	699	0.64
	0.8	1852	760	0.70
	1	-	-	-
	1.2	-	-	-
	1.4	-	-	-
	1.6	-	-	-
T2**	0.2	2594	614	0.65
	0.4	2480	655	0.70
	0.6	2280	720	0.77
	0.8	2098	778	0.83
	1	1941	826	0.88
	1.2	1778	871	0.93
	1.4	-	-	-
	1.6	-	-	-
T3	0.2	3775	796	1.65
	0.4	3641	838	1.74
	0.6	3562	863	1.79
	0.8	3456	901	1.87
	1	3350	939	1.95
	1.2	3242	972	2.02
	1.4	3077	1017	2.11
	1.6	2962	1051	2.18
T4	0.2	4174	857	2.17
	0.4	4060	892	2.26
	0.6	3956	921	2.33
	0.8	3854	955	2.42
	1	3749	990	2.50
	1.2	3643	1023	2.59
	1.4	3524	1057	2.67
	1.6	3413	1090	2.76
T5	0.2	4267	871	2.31
	0.4	4161	903	2.39
	0.6	4042	936	2.48
	0.8	3938	970	2.57
	1	3831	1003	2.66
	1.2	3723	1037	2.75
	1.4	3619	1068	2.83
	1.6	3507	1101	2.92
1.8	3400	1131	3.00	

Horizontal Flow				
Speed Tap	ESP	CFM	RPM	BHP
T1**	0.2	2513	549	0.50
	0.4	2344	608	0.56
	0.6	2180	667	0.61
	0.8	1957	739	0.68
	1	1747	798	0.73
	1.2	-	-	-
	1.4	-	-	-
	1.6	-	-	-
T2**	0.2	2719	579	0.62
	0.4	2559	634	0.67
	0.6	2404	689	0.73
	0.8	2213	753	0.80
	1	2022	809	0.86
	1.2	1872	862	0.92
	1.4	-	-	-
	1.6	-	-	-
T3	0.2	3921	754	1.56
	0.4	3804	791	1.64
	0.6	3690	826	1.71
	0.8	3608	861	1.79
	1	3501	900	1.87
	1.2	3382	939	1.95
	1.4	3241	977	2.03
	1.6	3109	1029	2.13
T4	0.2	4323	815	2.06
	0.4	4211	849	2.15
	0.6	4106	881	2.23
	0.8	4003	915	2.31
	1	3906	951	2.40
	1.2	3799	986	2.49
	1.4	3693	1018	2.57
	1.6	3590	1060	2.68
T5	0.2	4415	829	2.20
	0.4	4304	863	2.29
	0.6	4199	895	2.37
	0.8	4083	930	2.46
	1	3987	965	2.56
	1.2	3883	999	2.65
	1.4	3785	1032	2.74
	1.6	3691	1069	2.83
1.8	3584	1103	2.92	

8.5 Ton Fan Data • 180 MBH Gas Heat Exchange • Models: DSG1023W, DSG1024W, DSG1027W

Down Flow				
Speed Tap	ESP	CFM	RPM	BHP
T6**	0.2	2407	585	0.54
	0.4	2302	625	0.58
	0.6	2068	700	0.65
	0.8	1868	762	0.71
	1	-	-	-
	1.2	-	-	-
	1.4	-	-	-
	1.6	-	-	-
T7**	0.2	2994	676	0.93
	0.4	2865	720	0.99
	0.6	2727	765	1.05
	0.8	2577	815	1.12
	1	2443	860	1.18
	1.2	2305	900	1.23
	1.4	2107	955	1.31
	1.6	1968	996	1.36
T8	0.2	3505	755	1.37
	0.4	3368	799	1.45
	0.6	3281	827	1.50
	0.8	3163	869	1.57
	1	3051	909	1.65
	1.2	2936	944	1.71
	1.4	2753	993	1.80
	1.6	2632	1030	1.86
T9	0.2	4174	857	2.17
	0.4	4060	892	2.26
	0.6	3956	921	2.33
	0.8	3854	955	2.42
	1	3749	990	2.50
	1.2	3643	1023	2.59
	1.4	3524	1057	2.67
	1.6	3413	1090	2.76
T10	0.2	4267	871	2.31
	0.4	4161	903	2.39
	0.6	4042	936	2.48
	0.8	3938	970	2.57
	1	3831	1003	2.66
	1.2	3723	1037	2.75
	1.4	3619	1068	2.83
	1.6	3507	1101	2.92

Horizontal Flow				
Speed Tap	ESP	CFM	RPM	BHP
T6**	0.2	2527	551	0.51
	0.4	2358	610	0.57
	0.6	2195	669	0.62
	0.8	1974	740	0.69
	1	1765	799	0.74
	1.2	-	-	-
	1.4	-	-	-
	1.6	-	-	-
T7**	0.2	3127	637	0.87
	0.4	2985	685	0.94
	0.6	2846	733	1.00
	0.8	2711	784	1.07
	1	2554	834	1.14
	1.2	2414	882	1.21
	1.4	2205	954	1.31
	1.6	2046	987	1.35
T8	0.2	3647	713	1.29
	0.4	3523	753	1.36
	0.6	3402	792	1.43
	0.8	3312	831	1.50
	1	3191	874	1.58
	1.2	3065	916	1.66
	1.4	2900	962	1.74
	1.6	2755	1012	1.83
T9	0.2	4323	815	2.06
	0.4	4211	849	2.15
	0.6	4106	881	2.23
	0.8	4003	915	2.31
	1	3906	951	2.40
	1.2	3799	986	2.49
	1.4	3693	1018	2.57
	1.6	3590	1060	2.68
T10	0.2	4415	829	2.20
	0.4	4304	863	2.29
	0.6	4199	895	2.37
	0.8	4083	930	2.46
	1	3987	965	2.56
	1.2	3883	999	2.65
	1.4	3785	1032	2.74
	1.6	3691	1069	2.83

Shaded speed tap - Gas heating airflow.
 **(T1) (T2) and (T6)(T7) are part load only.

8.5 Ton Fan Data • 225 MBH Gas Heat Exchange • Models: DSG1023D, DSG1024D, DSG1027D

Down Flow				
Speed Tap	ESP	CFM	RPM	BHP
T1**	0.2	2038	544	0.36
	0.4	1850	607	0.40
	0.6	-	-	-
	0.8	-	-	-
T2**	0.2	2291	586	0.48
	0.4	2128	640	0.52
	0.6	1970	707	0.58
	0.8	1846	765	0.63
T3	0.2	3351	759	1.23
	0.4	3265	789	1.28
	0.6	3161	837	1.35
	0.8	3028	878	1.42
T4	0.2	3571	795	1.45
	0.4	3492	824	1.50
	0.6	3397	868	1.58
	0.8	3269	906	1.65
T5	0.2	3708	817	1.60
	0.4	3632	847	1.66
	0.6	3540	888	1.74
	0.8	3417	924	1.81
T6**	0.2	2476	616	0.58
	0.4	2329	664	0.63
	0.6	2183	728	0.69
	0.8	2054	783	0.74
T7**	0.2	3174	730	0.69
	0.4	3078	762	0.72
	0.6	2968	813	0.77
	0.8	2833	857	0.81
T8	0.2	3735	822	1.63
	0.4	3659	851	1.69
	0.6	3568	892	1.77
	0.8	3447	928	1.84
T9	0.2	3571	795	1.45
	0.4	3492	824	1.50
	0.6	3397	868	1.58
	0.8	3269	906	1.65
T10	0.2	3708	817	1.60
	0.4	3632	847	1.66
	0.6	3540	888	1.74
	0.8	3417	924	1.81

Horizontal Flow				
Speed Tap	ESP	CFM	RPM	BHP
T1**	0.2	2106	500	0.33
	0.4	1914	583	0.38
	0.6	1701	659	0.43
	0.8	-	-	-
T2**	0.2	2374	537	0.44
	0.4	2201	611	0.50
	0.6	2010	680	0.56
	0.8	1907	744	0.61
T3	0.2	3487	695	1.12
	0.4	3374	737	1.19
	0.6	3257	785	1.27
	0.8	3133	829	1.34
T4	0.2	3714	729	1.33
	0.4	3609	767	1.40
	0.6	3500	812	1.48
	0.8	3379	852	1.55
T5	0.2	3855	750	1.47
	0.4	3753	787	1.54
	0.6	3647	830	1.63
	0.8	3530	868	1.70
T6**	0.2	2570	564	0.53
	0.4	2409	631	0.59
	0.6	2234	697	0.66
	0.8	2124	756	0.71
T7**	0.2	3302	668	0.63
	0.4	3182	714	0.67
	0.6	3055	765	0.72
	0.8	2931	812	0.77
T8	0.2	3882	754	1.50
	0.4	3781	791	1.57
	0.6	3676	834	1.66
	0.8	3560	872	1.73
T9	0.2	3714	729	1.33
	0.4	3609	767	1.40
	0.6	3500	812	1.48
	0.8	3379	852	1.55
T10	0.2	3855	750	1.47
	0.4	3753	787	1.54
	0.6	3647	830	1.63
	0.8	3530	868	1.70

Shaded speed tap - Gas heating airflow.
 **(T1) (T2) and (T6)(T7) are part load only.

8.5 Ton Fan Data • 225 MBH Gas Heat Exchange • Models: DSG1023L, DSG1024L, DSG1027L

Down Flow				
Speed Tap	ESP	CFM	RPM	BHP
T1**	0.2	2298	587	0.48
	0.4	2136	641	0.52
	0.6	1979	708	0.58
	0.8	1854	766	0.62
	1	-	-	-
	1.2	-	-	-
T2**	0.2	2441	610	0.55
	0.4	2291	660	0.60
	0.6	2143	724	0.66
	0.8	2015	780	0.71
	1	1840	830	0.75
	1.2	-	-	-
T3	0.2	3610	801	1.46
	0.4	3532	830	1.51
	0.6	3438	873	1.59
	0.8	3311	911	1.66
	1	3194	949	1.73
	1.2	3034	989	1.80
T4	0.2	3945	856	1.87
	0.4	3867	889	1.94
	0.6	3780	926	2.02
	0.8	3671	960	2.09
	1	3566	994	2.17
	1.2	3424	1031	2.25
T5	0.2	4057	874	2.03
	0.4	3976	911	2.11
	0.6	3889	945	2.19
	0.8	3790	978	2.27
	1	3687	1012	2.35
	1.2	3552	1047	2.43
T6**	0.2	2746	660	0.74
	0.4	2621	701	0.78
	0.6	2490	760	0.85
	0.8	2356	810	0.90
	1	2198	857	0.95
	1.2	1986	908	1.01
T7**	0.2	3446	775	1.29
	0.4	3363	804	1.34
	0.6	3264	850	1.42
	0.8	3132	889	1.49
	1	3008	929	1.55
	1.2	2838	971	1.62
T8	0.2	3983	862	1.92
	0.4	3905	896	2.00
	0.6	3818	932	2.08
	0.8	3712	966	2.15
	1	3608	1000	2.23
	1.2	3468	1036	2.31
T9	0.2	3945	856	1.87
	0.4	3867	889	1.94
	0.6	3780	926	2.02
	0.8	3671	960	2.09
	1	3566	994	2.17
	1.2	3424	1031	2.25
T10	0.2	4057	874	2.03
	0.4	3976	911	2.11
	0.6	3889	945	2.19
	0.8	3790	978	2.27
	1	3687	1012	2.35
	1.2	3552	1047	2.43

Horizontal Flow				
Speed Tap	ESP	CFM	RPM	BHP
T1**	0.2	2382	538	0.44
	0.4	2209	611	0.50
	0.6	2019	681	0.55
	0.8	1915	744	0.60
	1	1725	803	0.65
	1.2	-	-	-
T2**	0.2	2533	559	0.51
	0.4	2370	627	0.57
	0.6	2192	693	0.63
	0.8	2083	754	0.68
	1	1903	811	0.73
	1.2	1716	871	0.79
T3	0.2	3754	735	1.34
	0.4	3650	773	1.41
	0.6	3542	817	1.49
	0.8	3422	857	1.56
	1	3314	899	1.64
	1.2	3201	944	1.72
T4	0.2	4096	788	1.72
	0.4	3995	824	1.80
	0.6	3892	865	1.89
	0.8	3787	900	1.96
	1	3690	938	2.05
	1.2	3596	977	2.13
T5	0.2	4209	807	1.87
	0.4	4106	843	1.96
	0.6	4001	883	2.05
	0.8	3906	917	2.13
	1	3810	954	2.21
	1.2	3722	991	2.30
T6**	0.2	2854	604	0.67
	0.4	2711	662	0.74
	0.6	2556	722	0.80
	0.8	2438	776	0.86
	1	2280	830	0.92
	1.2	2113	886	0.99
T7**	0.2	3585	709	1.18
	0.4	3476	750	1.25
	0.6	3363	797	1.33
	0.8	3239	839	1.40
	1	3123	883	1.48
	1.2	3001	930	1.55
T8	0.2	4135	794	1.77
	0.4	4034	830	1.85
	0.6	3930	871	1.94
	0.8	3828	906	2.02
	1	3732	943	2.10
	1.2	3639	982	2.19
T9	0.2	4096	788	1.72
	0.4	3995	824	1.80
	0.6	3892	865	1.89
	0.8	3787	900	1.96
	1	3690	938	2.05
	1.2	3596	977	2.13
T10	0.2	4209	807	1.87
	0.4	4106	843	1.96
	0.6	4001	883	2.05
	0.8	3906	917	2.13
	1	3810	954	2.21
	1.2	3722	991	2.30

Shaded speed tap - Gas heating airflow.
 **(T1) (T2) and (T6)(T7) are part load only.

8.5 Ton Fan Data • 225 MBH Gas Heat Exchange • Models: DSG1023W, DSG1024W, DSG1027W

Down Flow				
Speed Tap	ESP	CFM	RPM	BHP
T1**	0.2	2378	617	0.52
	0.4	2222	663	0.56
	0.6	2070	714	0.62
	0.8	1943	759	0.67
	1	1765	801	0.71
	1.2	-	-	-
	1.4	-	-	-
	1.6	-	-	-
T2**	0.2	2566	711	0.62
	0.4	2427	760	0.67
	0.6	2285	813	0.73
	0.8	2155	862	0.78
	1	1987	906	0.83
	1.2	1764	950	0.88
	1.4	-	-	-
	1.6	-	-	-
T3	0.2	3775	1607	1.65
	0.4	3699	1674	1.71
	0.6	3609	1740	1.79
	0.8	3490	1808	1.86
	1	3379	1870	1.93
	1.2	3228	1930	2.01
	1.4	3070	1997	2.09
	1.6	3023	2066	2.17
T4	0.2	4057	1954	2.03
	0.4	3976	2026	2.11
	0.6	3889	2096	2.19
	0.8	3790	2166	2.27
	1	3687	2231	2.35
	1.2	3552	2296	2.43
	1.4	3416	2366	2.51
	1.6	3383	2438	2.60
T5	0.2	4136	2072	2.15
	0.4	4050	2145	2.25
	0.6	3963	2217	2.33
	0.8	3872	2287	2.41
	1	3772	2353	2.49
	1.2	3640	2419	2.57
	1.4	3512	2489	2.66
	1.6	3486	2562	2.74
1.8	3400	2634	2.83	

Horizontal Flow				
Speed Tap	ESP	CFM	RPM	BHP
T1**	0.2	2465	550	0.47
	0.4	2298	620	0.54
	0.6	2115	688	0.59
	0.8	2008	750	0.65
	1	1824	808	0.70
	1.2	-	-	-
	1.4	-	-	-
	1.6	-	-	-
T2**	0.2	2664	577	0.57
	0.4	2510	641	0.63
	0.6	2341	705	0.70
	0.8	2228	763	0.75
	1	2058	818	0.81
	1.2	1879	877	0.87
	1.4	1712	936	0.93
	1.6	-	-	-
T3	0.2	3923	761	1.51
	0.4	3822	797	1.59
	0.6	3718	839	1.67
	0.8	3604	877	1.75
	1	3502	917	1.83
	1.2	3399	959	1.91
	1.4	3265	1002	1.99
	1.6	3097	1058	2.11
T4	0.2	4209	807	1.87
	0.4	4106	843	1.96
	0.6	4001	883	2.05
	0.8	3906	917	2.13
	1	3810	954	2.21
	1.2	3722	991	2.30
	1.4	3611	1029	2.39
	1.6	3482	1075	2.50
T5	0.2	4288	820	1.99
	0.4	4183	857	2.08
	0.6	4075	897	2.18
	0.8	3988	931	2.26
	1	3893	966	2.35
	1.2	3807	1002	2.43
	1.4	3706	1038	2.52
	1.6	3593	1080	2.62
1.8	3487	1120	2.72	

8.5 Ton Fan Data • 225 MBH Gas Heat Exchange • Models: DSG1023W, DSG1024W, DSG1027W

Down Flow				
Speed Tap	ESP	CFM	RPM	BHP
T6**	0.2	2874	886	0.82
	0.4	2759	939	0.87
	0.6	2634	995	0.94
	0.8	2499	1050	0.99
	1	2348	1098	1.05
	1.2	2144	1146	1.11
	1.4	1938	1200	1.16
	1.6	1895	1253	1.22
T7**	1.8	1739	1304	1.28
	0.2	3547	1383	1.39
	0.4	3467	1446	1.45
	0.6	3371	1510	1.52
	0.8	3242	1575	1.59
	1	3123	1633	1.66
	1.2	2959	1690	1.73
	1.4	2786	1755	1.81
T8	1.6	2735	1820	1.88
	1.8	2592	1887	1.96
	0.2	4057	1954	2.03
	0.4	3976	2026	2.11
	0.6	3889	2096	2.19
	0.8	3790	2166	2.27
	1	3687	2231	2.35
	1.2	3552	2296	2.43
T9	1.4	3416	2366	2.51
	1.6	3383	2438	2.60
	1.8	3285	2510	2.69
	0.2	4126	2057	2.14
	0.4	4041	2130	2.23
	0.6	3954	2201	2.31
	0.8	3862	2271	2.39
	1	3761	2337	2.47
T10	1.2	3629	2403	2.55
	1.4	3500	2473	2.64
	1.6	3473	2545	2.72
	1.8	3385	2617	2.81
	0.2	4191	2161	2.25
	0.4	4101	2235	2.35
	0.6	4012	2307	2.43
	0.8	3929	2378	2.51
T10	1	3829	2445	2.60
	1.2	3700	2512	2.68
	1.4	3578	2582	2.76
	1.6	3557	2655	2.85
	1.8	3481	2726	2.93

Horizontal Flow				
Speed Tap	ESP	CFM	RPM	BHP
T6**	0.2	2988	623	0.75
	0.4	2853	677	0.82
	0.6	2707	734	0.89
	0.8	2586	786	0.95
	1	2437	838	1.01
	1.2	2279	893	1.08
	1.4	2114	948	1.14
	1.6	1922	1008	1.22
T7**	1.8	1762	1052	1.27
	0.2	3689	725	1.28
	0.4	3583	764	1.35
	0.6	3474	809	1.43
	0.8	3352	849	1.50
	1	3241	893	1.57
	1.2	3125	938	1.66
	1.4	2979	985	1.74
T8	1.6	2794	1044	1.84
	1.8	2652	1090	1.92
	0.2	4209	807	1.87
	0.4	4106	843	1.96
	0.6	4001	883	2.05
	0.8	3906	917	2.13
	1	3810	954	2.21
	1.2	3722	991	2.30
T9	1.4	3611	1029	2.39
	1.6	3482	1075	2.50
	1.8	3369	1116	2.59
	0.2	4278	818	1.97
	0.4	4173	855	2.06
	0.6	4065	896	2.16
	0.8	3977	929	2.24
	1	3882	965	2.33
T10	1.2	3797	1000	2.41
	1.4	3694	1037	2.50
	1.6	3578	1080	2.61
	1.8	3472	1119	2.70
	0.2	4342	829	2.08
	0.4	4234	867	2.17
	0.6	4123	908	2.28
	0.8	4043	941	2.36
T10	1	3948	976	2.45
	1.2	3865	1010	2.53
	1.4	3770	1046	2.62
	1.6	3670	1084	2.72
	1.8	3569	1122	2.81

Shaded speed tap - Gas heating airflow.
 **(T1) (T2) and (T6)(T7) are part load only.

10.0 Ton Fan Data • 130 MBH Gas Heat Exchange • DSG1203D, DSG1204D, DSG1207D

Down Flow				
Speed Tap	ESP	CFM	RPM	BHP
T1**	0.2	2116	500	0.35
	0.4	-	-	-
	0.6	-	-	-
	0.8	-	-	-
T2**	0.2	2346	530	0.45
	0.4	2091	604	0.51
	0.6	-	-	-
	0.8	-	-	-
T3	0.2	3452	679	1.14
	0.4	3329	722	1.21
	0.6	3174	773	1.29
	0.8	2958	835	1.39
T4	0.2	4228	791	1.95
	0.4	4118	828	2.04
	0.6	4003	868	2.13
	0.8	3861	910	2.24
T5	0.2	4353	810	2.12
	0.4	4232	849	2.23
	0.6	4118	887	2.33
	0.8	4000	923	2.42
T6**	0.2	2116	500	0.35
	0.4	-	-	-
	0.6	-	-	-
	0.8	-	-	-
T7**	0.2	2189	510	0.35
	0.4	-	-	-
	0.6	-	-	-
	0.8	-	-	-
T8	0.2	2261	519	0.41
	0.4	-	-	-
	0.6	-	-	-
	0.8	-	-	-
T9	0.2	4228	791	1.95
	0.4	4118	828	2.04
	0.6	4003	868	2.13
	0.8	3861	910	2.24
T10	0.2	4353	810	2.12
	0.4	4232	849	2.23
	0.6	4118	887	2.33
	0.8	4000	923	2.42

Horizontal Flow				
Speed Tap	ESP	CFM	RPM	BHP
T1**	0.2	2044	494	0.34
	0.4	-	-	-
	0.6	-	-	-
	0.8	-	-	-
T2**	0.2	2326	519	0.44
	0.4	2146	580	0.49
	0.6	-	-	-
	0.8	-	-	-
T3	0.2	3601	646	1.08
	0.4	3491	688	1.15
	0.6	3348	739	1.23
	0.8	3122	795	1.33
T4	0.2	4364	751	1.85
	0.4	4267	789	1.94
	0.6	4165	827	2.04
	0.8	4034	868	2.13
T5	0.2	4465	771	2.02
	0.4	4365	810	2.12
	0.6	4262	847	2.22
	0.8	4158	887	2.33
T6**	0.2	2044	494	0.34
	0.4	-	-	-
	0.6	-	-	-
	0.8	-	-	-
T7**	0.2	2134	502	0.35
	0.4	-	-	-
	0.6	-	-	-
	0.8	-	-	-
T8	0.2	2222	510	0.40
	0.4	2035	572	0.45
	0.6	-	-	-
	0.8	-	-	-
T9	0.2	4364	751	1.85
	0.4	4267	789	1.94
	0.6	4165	827	2.04
	0.8	4034	868	2.13
T10	0.2	4465	771	2.02
	0.4	4365	810	2.12
	0.6	4262	847	2.22
	0.8	4158	887	2.33

Shaded speed tap - Gas heating airflow.
 **(T1) (T2) and (T6)(T7) are part load only.

10 Ton Fan Data • 130 MBH Gas Heat Exchange • Models: DSG1203L, DSG1204L, DSG1207L

Down Flow				
Speed Tap	ESP	CFM	RPM	BHP
T1**	0.2	2371	573	0.51
	0.4	2177	639	0.57
	0.6	-	-	-
	0.8	-	-	-
	1	-	-	-
	1.2	-	-	-
T2**	0.2	2613	604	0.62
	0.4	2432	667	0.68
	0.6	2222	723	0.74
	0.8	2159	786	0.80
	1	-	-	-
	1.2	-	-	-
T3	0.2	3758	760	1.30
	0.4	3640	804	1.38
	0.6	3515	847	1.45
	0.8	3384	891	1.52
	1	3236	936	1.60
	1.2	3077	979	1.68
T4	0.2	4577	879	2.06
	0.4	4493	911	2.14
	0.6	4411	946	2.22
	0.8	4259	979	2.30
	1	4137	1015	2.38
	1.2	4018	1056	2.48
T5	0.2	4699	897	2.21
	0.4	4618	929	2.28
	0.6	4540	962	2.37
	0.8	4390	994	2.44
	1	4272	1029	2.53
	1.2	4158	1069	2.63
T6**	0.2	2312	565	0.49
	0.4	2114	632	0.54
	0.6	-	-	-
	0.8	-	-	-
	1	-	-	-
	1.2	-	-	-
T7**	0.2	2650	609	0.63
	0.4	2472	671	0.70
	0.6	2266	727	0.76
	0.8	2200	789	0.82
	1	2017	848	0.88
	1.2	-	-	-
T8	0.2	3146	676	0.89
	0.4	2996	729	0.96
	0.6	2828	779	1.03
	0.8	2729	833	1.10
	1	2562	886	1.17
	1.2	2372	928	1.23
T9	0.2	4577	879	2.06
	0.4	4493	911	2.14
	0.6	4411	946	2.22
	0.8	4259	979	2.30
	1	4137	1015	2.38
	1.2	4018	1056	2.48
T10	0.2	4699	897	2.21
	0.4	4618	929	2.28
	0.6	4540	962	2.37
	0.8	4390	994	2.44
	1	4272	1029	2.53
	1.2	4158	1069	2.63

Horizontal Flow				
Speed Tap	ESP	CFM	RPM	BHP
T1**	0.2	2468	525	0.47
	0.4	2305	600	0.53
	0.6	2110	663	0.59
	0.8	-	-	-
	1	-	-	-
	1.2	-	-	-
T2**	0.2	2720	554	0.56
	0.4	2567	624	0.64
	0.6	2386	684	0.70
	0.8	2229	742	0.76
	1	2123	801	0.82
	1.2	-	-	-
T3	0.2	3916	696	1.19
	0.4	3808	743	1.27
	0.6	3688	788	1.35
	0.8	3559	834	1.43
	1	3413	882	1.51
	1.2	3262	931	1.59
T4	0.2	4773	803	1.88
	0.4	4690	836	1.96
	0.6	4605	872	2.05
	0.8	4498	910	2.13
	1	4347	949	2.23
	1.2	4229	988	2.32
T5	0.2	4901	819	2.01
	0.4	4821	851	2.09
	0.6	4739	885	2.18
	0.8	4636	922	2.27
	1	4487	960	2.36
	1.2	4375	998	2.45
T6**	0.2	4901	819	2.01
	0.4	4821	851	2.09
	0.6	4739	885	2.18
	0.8	4636	922	2.27
	1	4487	960	2.36
	1.2	4375	998	2.45
T7**	0.2	2759	559	0.58
	0.4	2608	628	0.65
	0.6	2429	687	0.71
	0.8	2273	745	0.77
	1	2165	804	0.84
	1.2	-	-	-
T8	0.2	3276	620	0.82
	0.4	3146	678	0.90
	0.6	2994	731	0.97
	0.8	2850	783	1.04
	1	2722	837	1.11
	1.2	2547	895	1.18
T9	0.2	4773	803	1.88
	0.4	4690	836	1.96
	0.6	4605	872	2.05
	0.8	4498	910	2.13
	1	4347	949	2.23
	1.2	4229	988	2.32
T10	0.2	4901	819	2.01
	0.4	4821	851	2.09
	0.6	4739	885	2.18
	0.8	4636	922	2.27
	1	4487	960	2.36
	1.2	4375	998	2.45

Shaded speed tap - Gas heating airflow.
 **(T1) (T2) and (T6)(T7) are part load only.

10.0 Ton Fan Data • 130 MBH Gas Heat Exchange • Models: DSG1203W, DSG1204W, DSG1207W

Down Flow				
Speed Tap	ESP	CFM	RPM	BHP
T1**	0.2	2536	594	0.58
	0.4	2352	658	0.64
	0.6	2135	715	0.70
	0.8	2078	779	0.76
	1	-	-	-
	1.2	-	-	-
	1.4	-	-	-
	1.6	-	-	-
T2**	0.2	2753	623	0.68
	0.4	2581	683	0.75
	0.6	2383	738	0.81
	0.8	2309	798	0.87
	1	2130	856	0.94
	1.2	-	-	-
	1.4	-	-	-
	1.6	-	-	-
T3	0.2	4026	798	1.52
	0.4	3920	838	1.59
	0.6	3812	878	1.67
	0.8	3670	918	1.74
	1	3531	960	1.82
	1.2	3385	1003	1.91
	1.4	3228	1046	1.99
	1.6	3062	1089	2.07
T4	0.2	4844	920	2.39
	0.4	4767	950	2.47
	0.6	4692	982	2.56
	0.8	4545	1012	2.63
	1	4431	1046	2.72
	1.2	4324	1085	2.82
	1.4	4178	1123	2.92
	1.6	4011	1157	3.01
T5	0.2	4973	941	2.58
	0.4	4899	969	2.66
	0.6	4826	1001	2.74
	0.8	4684	1030	2.82
	1	4574	1062	2.91
	1.2	4471	1100	3.01
	1.4	4330	1137	3.12
	1.6	4168	1169	3.20
1.8	4001	1209	3.31	

Horizontal Flow				
Speed Tap	ESP	CFM	RPM	BHP
T1**	0.2	2640	545	0.53
	0.4	2484	616	0.60
	0.6	2299	678	0.66
	0.8	2140	736	0.72
	1	2038	796	0.78
	1.2	-	-	-
	1.4	-	-	-
	1.6	-	-	-
T2**	0.2	2866	572	0.63
	0.4	2719	638	0.70
	0.6	2546	696	0.76
	0.8	2393	753	0.82
	1	2281	811	0.89
	1.2	2090	873	0.96
	1.4	-	-	-
	1.6	-	-	-
T3	0.2	4196	730	1.39
	0.4	4097	772	1.47
	0.6	3990	814	1.55
	0.8	3868	857	1.63
	1	3717	902	1.72
	1.2	3576	948	1.80
	1.4	3431	995	1.89
	1.6	3266	1041	1.98
T4	0.2	5054	839	2.18
	0.4	4976	870	2.26
	0.6	4898	902	2.35
	0.8	4799	938	2.44
	1	4655	974	2.54
	1.2	4549	1010	2.63
	1.4	4426	1054	2.74
	1.6	4288	1096	2.85
T5	0.2	5189	858	2.35
	0.4	5114	887	2.43
	0.6	5039	918	2.52
	0.8	4944	952	2.61
	1	4805	988	2.71
	1.2	4705	1022	2.80
	1.4	4587	1064	2.92
	1.6	4456	1105	3.03
1.8	4292	1141	3.13	

10.0 Ton Fan Data • 130 MBH Gas Heat Exchange • Models: DSG1203W, DSG1204W, DSG1207W

Down Flow				
Speed Tap	ESP	CFM	RPM	BHP
T6**	0.2	2111	539	0.41
	0.4	-	-	-
	0.6	-	-	-
	0.8	-	-	-
	1	-	-	-
	1.2	-	-	-
	1.4	-	-	-
	1.6	-	-	-
	1.8	-	-	-
T7**	0.2	2650	609	0.63
	0.4	2472	671	0.70
	0.6	2266	727	0.76
	0.8	2200	789	0.82
	1	2017	848	0.88
	1.2	-	-	-
	1.4	-	-	-
	1.6	-	-	-
	1.8	-	-	-
T8	0.2	3146	676	0.89
	0.4	2996	729	0.96
	0.6	2828	779	1.03
	0.8	2729	833	1.10
	1	2562	886	1.17
	1.2	2372	928	1.23
	1.4	2217	973	1.29
	1.6	2085	1024	1.35
	1.8	2003	1059	1.40
T9	0.2	4844	920	2.39
	0.4	4767	950	2.47
	0.6	4692	982	2.56
	0.8	4545	1012	2.63
	1	4431	1046	2.72
	1.2	4324	1085	2.82
	1.4	4178	1123	2.92
	1.6	4011	1157	3.01
	1.8	3846	1198	3.12
T10	0.2	4973	941	2.58
	0.4	4899	969	2.66
	0.6	4826	1001	2.74
	0.8	4684	1030	2.82
	1	4574	1062	2.91
	1.2	4471	1100	3.01
	1.4	4330	1137	3.12
	1.6	4168	1169	3.20
	1.8	4001	1209	3.31

Horizontal Flow				
Speed Tap	ESP	CFM	RPM	BHP
T6**	0.2	2197	494	0.37
	0.4	2022	574	0.43
	0.6	-	-	-
	0.8	-	-	-
	1	-	-	-
	1.2	-	-	-
	1.4	-	-	-
	1.6	-	-	-
	1.8	-	-	-
T7**	0.2	2759	559	0.58
	0.4	2608	628	0.65
	0.6	2429	687	0.71
	0.8	2273	745	0.77
	1	2165	804	0.84
	1.2	-	-	-
	1.4	-	-	-
	1.6	-	-	-
	1.8	-	-	-
T8	0.2	3276	620	0.82
	0.4	3146	678	0.90
	0.6	2994	731	0.97
	0.8	2850	783	1.04
	1	2722	837	1.11
	1.2	2547	895	1.18
	1.4	2386	941	1.24
	1.6	2206	989	1.31
	1.8	2115	1044	1.38
T9	0.2	5054	839	2.18
	0.4	4976	870	2.26
	0.6	4898	902	2.35
	0.8	4799	938	2.44
	1	4655	974	2.54
	1.2	4549	1010	2.63
	1.4	4426	1054	2.74
	1.6	4288	1096	2.85
	1.8	4121	1132	2.95
T10	0.2	5189	858	2.35
	0.4	5114	887	2.43
	0.6	5039	918	2.52
	0.8	4944	952	2.61
	1	4805	988	2.71
	1.2	4705	1022	2.80
	1.4	4587	1064	2.92
	1.6	4456	1105	3.03
	1.8	4292	1141	3.13

Shaded speed tap - Gas heating airflow.
 **(T1) (T2) and (T6)(T7) are part load only.

10 Ton Fan Data • 180 MBH Gas Heat Exchange • Models: DSG1203D, DSG1204D, DFG1207D

Down Flow				
Speed Tap	ESP	CFM	RPM	BHP
T1**	0.2	2164	529	0.37
	0.4	-	-	-
	0.6	-	-	-
	0.8	-	-	-
T2**	0.2	2410	561	0.47
	0.4	2233	622	0.52
	0.6	2073	669	0.56
	0.8	-	-	-
T3	0.2	3406	693	1.03
	0.4	3307	736	1.09
	0.6	3211	778	1.16
	0.8	2987	838	1.24
T4	0.2	4183	803	1.74
	0.4	4104	841	1.82
	0.6	4000	883	1.91
	0.8	3873	923	2.00
T5	0.2	4305	821	1.89
	0.4	4221	859	1.98
	0.6	4106	903	2.08
	0.8	4004	938	2.16
T6**	0.2	2175	530	0.32
	0.4	1952	611	0.37
	0.6	1742	672	0.41
	0.8	-	-	-
T7**	0.2	2682	597	0.36
	0.4	2530	652	0.39
	0.6	2393	697	0.42
	0.8	2124	766	0.46
T8	0.2	3279	676	0.94
	0.4	3172	721	1.00
	0.6	3072	763	1.06
	0.8	2837	825	1.15
T9	0.2	4183	803	1.74
	0.4	4104	841	1.82
	0.6	4000	883	1.91
	0.8	3873	923	2.00
T10	0.2	4305	821	1.89
	0.4	4221	859	1.98
	0.6	4106	903	2.08
	0.8	4004	938	2.16

Horizontal Flow				
Speed Tap	ESP	CFM	RPM	BHP
T1**	0.2	2304	479	0.33
	0.4	2065	562	0.39
	0.6	-	-	-
	0.8	-	-	-
T2**	0.2	2549	506	0.42
	0.4	2343	582	0.49
	0.6	2162	643	0.54
	0.8	-	-	-
T3	0.2	3550	616	0.91
	0.4	3451	671	1.00
	0.6	3340	720	1.07
	0.8	3152	794	1.18
T4	0.2	4359	710	1.54
	0.4	4281	756	1.64
	0.6	4203	799	1.73
	0.8	4079	856	1.85
T5	0.2	4489	725	1.67
	0.4	4404	772	1.78
	0.6	4327	814	1.87
	0.8	4216	866	1.99
T6**	0.2	2136	461	0.28
	0.4	-	-	-
	0.6	-	-	-
	0.8	-	-	-
T7**	0.2	2820	535	0.32
	0.4	2649	605	0.37
	0.6	2489	662	0.40
	0.8	2251	739	0.45
T8	0.2	3421	601	0.84
	0.4	3312	659	0.92
	0.6	3193	709	0.99
	0.8	2996	784	1.09
T9	0.2	4359	710	1.54
	0.4	4281	756	1.64
	0.6	4203	799	1.73
	0.8	4079	856	1.85
T10	0.2	4489	725	1.67
	0.4	4404	772	1.78
	0.6	4327	814	1.87
	0.8	4216	866	1.99

Shaded speed tap - Gas heating airflow.
 **(T1) (T2) and (T6)(T7) are part load only.

10 Ton Fan Data • 180 MBH Gas Heat Exchange • Models: DSG1203L, DSG1204L, DSG1207L

Down Flow				
Speed Tap	ESP	CFM	RPM	BHP
T1**	0.2	2410	561	0.47
	0.4	2233	622	0.52
	0.6	2073	669	0.56
	0.8	-	-	-
	1	-	-	-
	1.2	-	-	-
T2**	0.2	2667	595	0.59
	0.4	2514	650	0.64
	0.6	2376	696	0.69
	0.8	2105	765	0.76
	1	-	-	-
	1.2	-	-	-
T3	0.2	3745	740	1.30
	0.4	3662	780	1.37
	0.6	3572	821	1.44
	0.8	3381	874	1.53
	1	3172	927	1.63
	1.2	2967	979	1.72
T4	0.2	4534	856	2.22
	0.4	4433	898	2.33
	0.6	4284	944	2.45
	0.8	4241	968	2.51
	1	4141	1009	2.62
	1.2	4043	1045	2.72
T5	0.2	4577	863	2.30
	0.4	4471	906	2.41
	0.6	4312	953	2.54
	0.8	4283	974	2.59
	1	4196	1014	2.70
	1.2	4110	1048	2.79
T6**	0.2	2567	582	0.54
	0.4	2405	639	0.59
	0.6	2259	685	0.64
	0.8	-	-	-
	1	-	-	-
	1.2	-	-	-
T7**	0.2	3213	667	0.90
	0.4	3103	713	0.96
	0.6	2999	756	1.02
	0.8	2760	818	1.10
	1	2529	876	1.18
	1.2	2311	930	1.25
T8	0.2	3756	742	1.31
	0.4	3673	781	1.38
	0.6	3584	823	1.45
	0.8	3394	875	1.54
	1	3185	928	1.64
	1.2	2981	980	1.73
T9	0.2	4534	856	2.22
	0.4	4433	898	2.33
	0.6	4284	944	2.45
	0.8	4241	968	2.51
	1	4141	1009	2.62
	1.2	4043	1045	2.72
T10	0.2	4577	863	2.30
	0.4	4471	906	2.41
	0.6	4312	953	2.54
	0.8	4283	974	2.59
	1	4196	1014	2.70
	1.2	4110	1048	2.79

Horizontal Flow				
Speed Tap	ESP	CFM	RPM	BHP
T1**	0.2	2549	506	0.42
	0.4	2343	582	0.49
	0.6	2162	643	0.54
	0.8	-	-	-
	1	-	-	-
	1.2	-	-	-
T2**	0.2	2805	533	0.53
	0.4	2632	604	0.60
	0.6	2471	661	0.65
	0.8	2232	738	0.73
	1	2035	796	0.79
	1.2	-	-	-
T3	0.2	3899	656	1.15
	0.4	3819	705	1.24
	0.6	3726	752	1.32
	0.8	3564	820	1.44
	1	3439	856	1.50
	1.2	3120	950	1.67
T4	0.2	4741	757	1.97
	0.4	4629	806	2.10
	0.6	4550	848	2.20
	0.8	4465	886	2.30
	1	4392	928	2.41
	1.2	4287	969	2.52
T5	0.2	4790	764	2.03
	0.4	4670	814	2.17
	0.6	4588	855	2.28
	0.8	4510	890	2.37
	1	4439	934	2.49
	1.2	4361	968	2.58
T6**	0.2	2705	523	0.49
	0.4	2520	595	0.55
	0.6	2351	654	0.61
	0.8	2107	730	0.68
	1	-	-	-
	1.2	-	-	-
T7**	0.2	3355	594	0.80
	0.4	3240	652	0.88
	0.6	3117	704	0.95
	0.8	2915	779	1.05
	1	2755	823	1.11
	1.2	2427	915	1.23
T8	0.2	3910	657	1.16
	0.4	3831	707	1.25
	0.6	3739	753	1.33
	0.8	3577	821	1.45
	1	3453	857	1.51
	1.2	3135	950	1.68
T9	0.2	4741	757	1.97
	0.4	4629	806	2.10
	0.6	4550	848	2.20
	0.8	4465	886	2.30
	1	4392	928	2.41
	1.2	4287	969	2.52
T10	0.2	4790	764	2.03
	0.4	4670	814	2.17
	0.6	4588	855	2.28
	0.8	4510	890	2.37
	1	4439	934	2.49
	1.2	4361	968	2.58

Shaded speed tap - Gas heating airflow.
 **(T1) (T2) and (T6)(T7) are part load only.

10 Ton Fan Data • 180 MBH Gas Heat Exchange • Models: DSG1203W, DSG1204W, DSG1207W

Down Flow				
Speed Tap	ESP	CFM	RPM	BHP
T1**	0.2	2589	586	0.56
	0.4	2393	658	0.63
	0.6	2205	713	0.68
	0.8	2110	781	0.74
	1	-	-	-
	1.2	-	-	-
	1.4	-	-	-
	1.6	-	-	-
T2**	0.2	2818	617	0.66
	0.4	2636	684	0.73
	0.6	2459	736	0.78
	0.8	2349	801	0.85
	1	2132	858	0.91
	1.2	-	-	-
	1.4	-	-	-
	1.6	-	-	-
T3	0.2	4089	788	1.41
	0.4	3978	829	1.49
	0.6	3859	868	1.56
	0.8	3682	917	1.64
	1	3518	962	1.72
	1.2	3383	998	1.79
	1.4	3211	1042	1.87
	1.6	3034	1087	1.95
T4	0.2	4931	901	2.21
	0.4	4853	930	2.28
	0.6	4762	961	2.35
	0.8	4568	1003	2.46
	1	4441	1040	2.55
	1.2	4332	1075	2.63
	1.4	4205	1110	2.72
	1.6	4003	1152	2.82
T5	0.2	5125	927	2.45
	0.4	5052	954	2.52
	0.6	4964	985	2.60
	0.8	4774	1025	2.71
	1	4656	1060	2.80
	1.2	4551	1095	2.90
	1.4	4435	1127	2.98
	1.6	4235	1168	3.09
1.8	4004	1217	3.22	

Horizontal Flow				
Speed Tap	ESP	CFM	RPM	BHP
T1**	0.2	2516	536	0.51
	0.4	2406	616	0.59
	0.6	2132	690	0.66
	0.8	-	-	-
	1	-	-	-
	1.2	-	-	-
	1.4	-	-	-
	1.6	-	-	-
T2**	0.2	2749	561	0.60
	0.4	2626	635	0.68
	0.6	2370	706	0.75
	0.8	2167	761	0.81
	1	-	-	-
	1.2	-	-	-
	1.4	-	-	-
	1.6	-	-	-
T3	0.2	4056	706	1.27
	0.4	3869	753	1.35
	0.6	3705	804	1.44
	0.8	3560	850	1.52
	1	3387	901	1.62
	1.2	3201	951	1.70
	1.4	2996	1005	1.80
	1.6	2773	1056	1.89
T4	0.2	4942	812	1.99
	0.4	4733	846	2.07
	0.6	4608	885	2.17
	0.8	4494	925	2.27
	1	4352	964	2.36
	1.2	4210	1007	2.47
	1.4	4039	1053	2.58
	1.6	3852	1103	2.70
T5	0.2	5152	840	2.22
	0.4	4942	871	2.30
	0.6	4821	908	2.40
	0.8	4712	947	2.50
	1	4578	983	2.60
	1.2	4445	1024	2.71
	1.4	4284	1068	2.82
	1.6	4110	1117	2.95
1.8	3931	1164	3.08	

10 Ton Fan Data • 180 MBH Gas Heat Exchange • Models: DSG1203W, DSG1204W, DSG1207W

Down Flow				
Speed Tap	ESP	CFM	RPM	BHP
T6**	0.2	2919	630	0.70
	0.4	2744	695	0.78
	0.6	2572	746	0.83
	0.8	2455	810	0.90
	1	2242	866	0.97
	1.2	2070	903	1.01
	1.4	-	-	-
	1.6	-	-	-
T7**	0.2	3792	748	1.20
	0.4	3666	795	1.27
	0.6	3535	836	1.34
	0.8	3370	889	1.43
	1	3193	936	1.50
	1.2	3050	973	1.56
	1.4	2860	1020	1.64
	1.6	2699	1066	1.71
T8	0.2	4506	844	1.76
	0.4	4414	878	1.84
	0.6	4310	913	1.91
	0.8	4120	958	2.00
	1	3974	999	2.09
	1.2	3853	1035	2.16
	1.4	3704	1074	2.25
	1.6	3510	1118	2.34
T9	0.2	4931	901	2.21
	0.4	4853	930	2.28
	0.6	4762	961	2.35
	0.8	4568	1003	2.46
	1	4441	1040	2.55
	1.2	4332	1075	2.63
	1.4	4205	1110	2.72
	1.6	4003	1152	2.82
T10	0.2	5125	927	2.45
	0.4	5052	954	2.52
	0.6	4964	985	2.60
	0.8	4774	1025	2.71
	1	4656	1060	2.80
	1.2	4551	1095	2.90
	1.4	4435	1127	2.98
	1.6	4235	1168	3.09

Horizontal Flow				
Speed Tap	ESP	CFM	RPM	BHP
T6**	0.2	2853	572	0.64
	0.4	2723	644	0.72
	0.6	2475	713	0.80
	0.8	2277	767	0.86
	1	2061	838	0.94
	1.2	-	-	-
	1.4	-	-	-
	1.6	-	-	-
T7**	0.2	3749	671	1.08
	0.4	3574	724	1.16
	0.6	3390	779	1.25
	0.8	3233	827	1.33
	1	3049	884	1.42
	1.2	2847	935	1.50
	1.4	2633	991	1.59
	1.6	2401	1041	1.67
T8	0.2	4492	757	1.58
	0.4	4291	796	1.66
	0.6	4149	842	1.76
	0.8	4021	885	1.85
	1	3863	930	1.94
	1.2	3700	976	2.04
	1.4	3510	1027	2.15
	1.6	3302	1078	2.25
T9	0.2	4942	812	1.99
	0.4	4733	846	2.07
	0.6	4608	885	2.17
	0.8	4494	925	2.27
	1	4352	964	2.36
	1.2	4210	1007	2.47
	1.4	4039	1053	2.58
	1.6	3852	1103	2.70
T10	0.2	5152	840	2.22
	0.4	4942	871	2.30
	0.6	4821	908	2.40
	0.8	4712	947	2.50
	1	4578	983	2.60
	1.2	4445	1024	2.71
	1.4	4284	1068	2.82
	1.6	4110	1117	2.95

Shaded speed tap - Gas heating airflow.
 **(T1) (T2) and (T6)(T7) are part load only.

10 Ton Fan Data • 240 MBH Gas Heat Exchange • Models: DSG1203D, DSG1204D, DSG1207D

Down Flow				
Speed Tap	ESP	CFM	RPM	BHP
T1**	0.2	2169	555	0.43
	0.4	-	-	-
	0.6	-	-	-
	0.8	-	-	-
T2**	0.2	2450	600	0.58
	0.4	2203	672	0.65
	0.6	2031	721	0.70
	0.8	-	-	-
T3	0.2	3421	761	1.34
	0.4	3321	797	1.40
	0.6	3197	841	1.48
	0.8	3004	896	1.57
T4	0.2	4193	895	2.36
	0.4	4099	930	2.46
	0.6	4003	962	2.54
	0.8	3908	994	2.63
T5	0.2	4287	912	2.54
	0.4	4177	951	2.65
	0.6	4083	980	2.73
	0.8	4012	1007	2.80
T6**	0.2	2463	602	0.59
	0.4	2218	673	0.66
	0.6	2047	722	0.70
	0.8	-	-	-
T7**	0.2	3093	706	0.69
	0.4	2954	751	0.73
	0.6	2814	798	0.78
	0.8	2605	855	0.83
T8	0.2	3620	795	1.55
	0.4	3536	827	1.61
	0.6	3420	869	1.69
	0.8	3242	921	1.79
T9	0.2	4193	895	2.36
	0.4	4099	930	2.46
	0.6	4003	962	2.54
	0.8	3908	994	2.63
T10	0.2	4287	912	2.54
	0.4	4177	951	2.65
	0.6	4083	980	2.73
	0.8	4012	1007	2.80

Horizontal Flow				
Speed Tap	ESP	CFM	RPM	BHP
T1**	0.2	2325	498	0.38
	0.4	2029	592	0.46
	0.6	-	-	-
	0.8	-	-	-
T2**	0.2	2623	536	0.52
	0.4	2379	615	0.59
	0.6	2138	687	0.66
	0.8	-	-	-
T3	0.2	3663	668	1.17
	0.4	3552	712	1.25
	0.6	3410	766	1.34
	0.8	3178	836	1.47
T4	0.2	4523	783	2.07
	0.4	4405	825	2.18
	0.6	4291	863	2.28
	0.8	4183	906	2.39
T5	0.2	4631	798	2.22
	0.4	4497	843	2.35
	0.6	4380	880	2.45
	0.8	4302	915	2.55
T6**	0.2	2636	537	0.52
	0.4	2395	616	0.60
	0.6	2155	688	0.67
	0.8	-	-	-
T7**	0.2	3308	622	0.61
	0.4	3163	676	0.66
	0.6	2992	736	0.72
	0.8	2743	808	0.79
T8	0.2	3881	696	1.36
	0.4	3782	737	1.44
	0.6	3654	786	1.53
	0.8	3439	854	1.66
T9	0.2	4523	783	2.07
	0.4	4405	825	2.18
	0.6	4291	863	2.28
	0.8	4183	906	2.39
T10	0.2	4631	798	2.22
	0.4	4497	843	2.35
	0.6	4380	880	2.45
	0.8	4302	915	2.55

Shaded speed tap - Gas heating airflow.
 **(T1) (T2) and (T6)(T7) are part load only.

10 Ton Fan Data • 240 MBH Gas Heat Exchange • Models: DSG1203L, DSG1204L, DSG1207L

Down Flow				
Speed Tap	ESP	CFM	RPM	BHP
T1**	0.2	2435	597	0.56
	0.4	2205	670	0.63
	0.6	-	-	-
	0.8	-	-	-
	1	-	-	-
	1.2	-	-	-
T2**	0.2	2697	640	0.71
	0.4	2491	706	0.78
	0.6	2279	760	0.84
	0.8	2125	805	0.89
	1	-	-	-
	1.2	-	-	-
T3	0.2	3443	762	1.25
	0.4	3299	808	1.32
	0.6	3141	852	1.39
	0.8	3002	892	1.46
	1	2825	939	1.53
	1.2	2617	991	1.62
T4	0.2	4573	951	2.52
	0.4	4490	976	2.59
	0.6	4395	1006	2.67
	0.8	4284	1039	2.76
	1	4157	1075	2.85
	1.2	4011	1118	2.97
T5	0.2	4708	974	2.73
	0.4	4627	998	2.80
	0.6	4538	1027	2.88
	0.8	4430	1058	2.97
	1	4311	1093	3.07
	1.2	4174	1134	3.18
T6**	0.2	3088	704	0.97
	0.4	2915	759	1.04
	0.6	2733	807	1.11
	0.8	2586	850	1.17
	1	2395	899	1.23
	1.2	2173	952	1.31
T7**	0.2	3941	845	1.72
	0.4	3830	880	1.79
	0.6	3704	917	1.87
	0.8	3576	954	1.94
	1	3419	997	2.03
	1.2	3236	1046	2.13
T8	0.2	4619	959	2.59
	0.4	4537	984	2.66
	0.6	4444	1013	2.74
	0.8	4334	1045	2.83
	1	4210	1081	2.92
	1.2	4067	1123	3.04
T9	0.2	4573	951	2.52
	0.4	4490	976	2.59
	0.6	4395	1006	2.67
	0.8	4284	1039	2.76
	1	4157	1075	2.85
	1.2	4011	1118	2.97
T10	0.2	4708	974	2.73
	0.4	4627	998	2.80
	0.6	4538	1027	2.88
	0.8	4430	1058	2.97
	1	4311	1093	3.07
	1.2	4174	1134	3.18

Horizontal Flow				
Speed Tap	ESP	CFM	RPM	BHP
T1**	0.2	2576	539	0.50
	0.4	2320	629	0.59
	0.6	2042	706	0.66
	0.8	-	-	-
	1	-	-	-
	1.2	-	-	-
T2**	0.2	2863	577	0.64
	0.4	2633	657	0.73
	0.6	2379	728	0.81
	0.8	2216	778	0.86
	1	-	-	-
	1.2	-	-	-
T3	0.2	3677	687	1.12
	0.4	3514	741	1.21
	0.6	3324	795	1.30
	0.8	3182	841	1.37
	1	2977	898	1.47
	1.2	2844	938	1.53
T4	0.2	4904	854	2.27
	0.4	4806	882	2.34
	0.6	4692	916	2.43
	0.8	4580	954	2.53
	1	4423	1002	2.66
	1.2	4333	1024	2.72
T5	0.2	5050	874	2.45
	0.4	4954	901	2.53
	0.6	4846	933	2.62
	0.8	4737	970	2.72
	1	4589	1015	2.85
	1.2	4501	1037	2.91
T6**	0.2	3289	634	0.87
	0.4	3096	701	0.96
	0.6	2876	763	1.05
	0.8	2725	810	1.11
	1	2511	868	1.19
	1.2	2359	917	1.26
T7**	0.2	4219	760	1.55
	0.4	4091	801	1.63
	0.6	3939	845	1.72
	0.8	3811	887	1.81
	1	3622	942	1.92
	1.2	3512	972	1.98
T8	0.2	4954	861	2.33
	0.4	4856	888	2.40
	0.6	4745	922	2.49
	0.8	4634	959	2.59
	1	4480	1006	2.72
	1.2	4391	1028	2.78
T9	0.2	4904	854	2.27
	0.4	4806	882	2.34
	0.6	4692	916	2.43
	0.8	4580	954	2.53
	1	4423	1002	2.66
	1.2	4333	1024	2.72
T10	0.2	5050	874	2.45
	0.4	4954	901	2.53
	0.6	4846	933	2.62
	0.8	4737	970	2.72
	1	4589	1015	2.85
	1.2	4501	1037	2.91

Shaded speed tap - Gas heating airflow.
 **(T1) (T2) and (T6)(T7) are part load only.

10 Ton Fan Data • 240 MBH Gas Heat Exchange • Models: DSG1203W, DSG1204W, DSG1207W

Down Flow				
Speed Tap	ESP	CFM	RPM	BHP
T1**	0.2	2635	630	0.67
	0.4	2423	697	0.74
	0.6	2206	752	0.80
	0.8	2051	798	0.85
	1	-	-	-
	1.2	-	-	-
	1.4	-	-	-
	1.6	-	-	-
T2**	0.2	2843	664	0.80
	0.4	2650	725	0.87
	0.6	2449	777	0.94
	0.8	2298	822	0.99
	1	2099	872	1.05
	1.2	-	-	-
	1.4	-	-	-
	1.6	-	-	-
T3	0.2	4057	864	1.85
	0.4	3952	897	1.92
	0.6	3833	932	2.00
	0.8	3708	968	2.07
	1	3556	1011	2.16
	1.2	3378	1059	2.27
	1.4	3234	1095	2.35
	1.6	3028	1144	2.45
T4	0.2	4833	996	2.95
	0.4	4753	1019	3.02
	0.6	4667	1047	3.10
	0.8	4564	1077	3.19
	1	4452	1110	3.29
	1.2	4325	1148	3.40
	1.4	4203	1179	3.49
	1.6	4016	1218	3.61
T5	0.2	4912	1009	3.09
	0.4	4831	1032	3.16
	0.6	4747	1060	3.25
	0.8	4646	1090	3.34
	1	4539	1121	3.43
	1.2	4419	1157	3.55
	1.4	4300	1188	3.64
	1.6	4120	1225	3.75

Horizontal Flow				
Speed Tap	ESP	CFM	RPM	BHP
T1**	0.2	2795	568	0.60
	0.4	2558	650	0.69
	0.6	2299	723	0.77
	0.8	2134	772	0.82
	1	-	-	-
	1.2	-	-	-
	1.4	-	-	-
	1.6	-	-	-
T2**	0.2	3022	598	0.72
	0.4	2806	673	0.81
	0.6	2566	741	0.89
	0.8	2407	790	0.95
	1	2188	848	1.02
	1.2	2022	903	1.09
	1.4	-	-	-
	1.6	-	-	-
T3	0.2	4344	777	1.66
	0.4	4224	815	1.74
	0.6	4080	857	1.84
	0.8	3955	899	1.92
	1	3770	952	2.04
	1.2	3665	980	2.10
	1.4	3441	1039	2.23
	1.6	3245	1093	2.34
T4	0.2	5185	893	2.64
	0.4	5089	919	2.72
	0.6	4987	950	2.81
	0.8	4880	985	2.92
	1	4742	1029	3.05
	1.2	4656	1050	3.11
	1.4	4510	1087	3.22
	1.6	4336	1141	3.38
T5	0.2	5270	905	2.77
	0.4	5173	931	2.85
	0.6	5072	961	2.95
	0.8	4968	996	3.05
	1	4836	1037	3.18
	1.2	4750	1059	3.24
	1.4	4613	1094	3.35
	1.6	4445	1147	3.51

10 Ton Fan Data • 240 MBH Gas Heat Exchange • Models: DSG1203W, DSG1204W, DSG1207W

Down Flow				
Speed Tap	ESP	CFM	RPM	BHP
T6**	0.2	2941	680	0.86
	0.4	2756	739	0.94
	0.6	2563	789	1.00
	0.8	2413	833	1.06
	1	2217	883	1.12
	1.2	-	-	-
	1.4	-	-	-
	1.6	-	-	-
T7**	0.2	3666	799	1.44
	0.4	3537	840	1.52
	0.6	3394	880	1.59
	0.8	3260	919	1.66
	1	3091	965	1.74
	1.2	2894	1016	1.84
	1.4	2740	1053	1.90
	1.6	2546	1104	2.00
T8	0.2	4276	901	2.11
	0.4	4182	930	2.18
	0.6	4074	963	2.26
	0.8	3955	997	2.34
	1	3813	1038	2.43
	1.2	3648	1084	2.54
	1.4	3509	1119	2.63
	1.6	3301	1166	2.74
T9	0.2	4833	996	2.95
	0.4	4753	1019	3.02
	0.6	4667	1047	3.10
	0.8	4564	1077	3.19
	1	4452	1110	3.29
	1.2	4325	1148	3.40
	1.4	4203	1179	3.49
	1.6	4016	1218	3.61
T10	0.2	4912	1009	3.09
	0.4	4831	1032	3.16
	0.6	4747	1060	3.25
	0.8	4646	1090	3.34
	1	4539	1121	3.43
	1.2	4419	1157	3.55
	1.4	4300	1188	3.64
	1.6	4120	1225	3.75

Horizontal Flow				
Speed Tap	ESP	CFM	RPM	BHP
T6**	0.2	3129	613	0.78
	0.4	2922	684	0.87
	0.6	2690	749	0.95
	0.8	2534	798	1.01
	1	2317	856	1.09
	1.2	2157	909	1.15
	1.4	1830	1011	1.28
	1.6	1673	1038	1.32
T7**	0.2	3919	719	1.30
	0.4	3772	767	1.39
	0.6	3601	817	1.48
	0.8	3465	861	1.56
	1	3266	917	1.66
	1.2	3144	953	1.72
	1.4	2883	1026	1.85
	1.6	2695	1073	1.94
T8	0.2	4582	810	1.90
	0.4	4473	843	1.98
	0.6	4343	881	2.07
	0.8	4224	921	2.16
	1	4049	973	2.28
	1.2	3952	998	2.34
	1.4	3749	1049	2.46
	1.6	3553	1106	2.59
T9	0.2	5185	893	2.64
	0.4	5089	919	2.72
	0.6	4987	950	2.81
	0.8	4880	985	2.92
	1	4742	1029	3.05
	1.2	4656	1050	3.11
	1.4	4510	1087	3.22
	1.6	4336	1141	3.38
T10	0.2	5270	905	2.77
	0.4	5173	931	2.85
	0.6	5072	961	2.95
	0.8	4968	996	3.05
	1	4836	1037	3.18
	1.2	4750	1059	3.24
	1.4	4613	1094	3.35
	1.6	4445	1147	3.51

Shaded speed tap - Gas heating airflow.
 **(T1) (T2) and (T6)(T7) are part load only.

12.5 Ton Fan Data • 130 MBH Gas Heat Exchange • Models: DSG1503D, DSG1504D, DSG1507D

Down Flow				
Speed Tap	ESP	CFM	RPM	BHP
T1**	0.2	2212	511	0.33
	0.4	1879	609	0.40
	0.6	1656	664	0.43
	0.8	1436	714	0.46
T2**	0.2	2495	550	0.45
	0.4	2213	636	0.53
	0.6	2022	689	0.57
	0.8	1801	741	0.61
T3	0.2	4262	803	1.79
	0.4	4181	839	1.87
	0.6	4087	876	1.96
	0.8	3951	923	2.06
T4	0.2	4637	860	2.30
	0.4	4542	898	2.40
	0.6	4424	934	2.50
	0.8	4346	966	2.58
T5	0.2	4718	873	2.43
	0.4	4614	912	2.54
	0.6	4485	948	2.64
	0.8	4425	975	2.72
T6**	0.2	1655	434	0.14
	0.4	-	-	-
	0.6	-	-	-
	0.8	-	-	-
T7**	0.2	1899	468	0.15
	0.4	1505	580	0.19
	0.6	-	-	-
	0.8	-	-	-
T8	0.2	2135	500	0.30
	0.4	1787	602	0.36
	0.6	1556	658	0.40
	0.8	-	-	-
T9	0.2	4637	860	2.30
	0.4	4542	898	2.40
	0.6	4424	934	2.50
	0.8	4346	966	2.58
T10	0.2	4718	873	2.43
	0.4	4614	912	2.54
	0.6	4485	948	2.64
	0.8	4425	975	2.72

Horizontal Flow				
Speed Tap	ESP	CFM	RPM	BHP
T1**	0.2	2299	481	0.31
	0.4	2056	573	0.37
	0.6	1747	660	0.43
	0.8	1568	711	0.46
T2**	0.2	2587	516	0.43
	0.4	2382	596	0.49
	0.6	2116	676	0.56
	0.8	1947	728	0.60
T3	0.2	4385	747	1.67
	0.4	4313	784	1.75
	0.6	4233	825	1.84
	0.8	4131	869	1.94
T4	0.2	4767	802	2.14
	0.4	4674	843	2.25
	0.6	4592	881	2.36
	0.8	4510	917	2.45
T5	0.2	4849	815	2.27
	0.4	4746	858	2.39
	0.6	4660	896	2.50
	0.8	4583	929	2.59
T6**	0.2	1732	413	0.13
	0.4	1407	529	0.17
	0.6	-	-	-
	0.8	-	-	-
T7**	0.2	1981	443	0.14
	0.4	1693	548	0.18
	0.6	1332	645	0.21
	0.8	-	-	-
T8	0.2	2221	472	0.28
	0.4	1967	566	0.34
	0.6	1645	656	0.40
	0.8	1464	707	0.43
T9	0.2	4767	802	2.14
	0.4	4674	843	2.25
	0.6	4592	881	2.36
	0.8	4510	917	2.45
T10	0.2	4849	815	2.27
	0.4	4746	858	2.39
	0.6	4660	896	2.50
	0.8	4583	929	2.59

Shaded speed tap - Gas heating airflow.
 **(T1) (T2) and (T6)(T7) are part load only.

12.5 Ton Fan Data • 130 MBH Gas Heat Exchange • Models: DSG1503L, DSG1504L, DSG1507L

Down Flow					Horizontal Flow				
Speed Tap	ESP	CFM	RPM	BHP	Speed Tap	ESP	CFM	RPM	BHP
T1**	0.2	2496	542	0.44	T1**	0.2	2431	515	0.42
	0.4	2223	624	0.51		0.4	2257	591	0.48
	0.6	1952	696	0.57		0.6	1904	688	0.56
	0.8	1785	742	0.61		0.8	1725	743	0.61
	1	1573	794	0.65		1	1516	798	0.65
	1.2	1361	836	0.68		1.2	-	-	-
	1.4	-	-	-		1.4	-	-	-
T2**	0.2	2788	584	0.58	T2**	0.2	2743	555	0.55
	0.4	2541	657	0.65		0.4	2583	624	0.62
	0.6	2296	723	0.72		0.6	2269	712	0.71
	0.8	2135	769	0.76		0.8	2103	765	0.76
	1	1925	820	0.81		1	1898	820	0.81
	1.2	1726	862	0.86		1.2	1688	873	0.87
	1.4	1471	907	0.90		1.4	1487	912	0.91
T3	0.2	4584	843	1.93	T3	0.2	4641	803	1.84
	0.4	4466	875	2.01		0.4	4549	839	1.92
	0.6	4356	911	2.09		0.6	4433	875	2.01
	0.8	4233	947	2.17		0.8	4334	916	2.10
	1	4059	994	2.28		1	4174	965	2.21
	1.2	3933	1030	2.36		1.2	4037	1007	2.31
	1.4	3701	1077	2.47		1.4	3877	1053	2.42
T4	0.2	5506	981	3.25	T4	0.2	5591	932	3.09
	0.4	5413	1007	3.33		0.4	5504	961	3.18
	0.6	5331	1034	3.42		0.6	5433	988	3.27
	0.8	5233	1064	3.52		0.8	5352	1020	3.38
	1	5121	1096	3.63		1	5247	1056	3.50
	1.2	5020	1128	3.73		1.2	5145	1089	3.61
	1.4	4861	1162	3.85		1.4	5031	1128	3.73
T5	0.2	5631	1001	3.50	T5	0.2	5717	950	3.15
	0.4	5537	1028	3.60		0.4	5627	979	3.24
	0.6	5452	1054	3.69		0.6	5553	1007	3.33
	0.8	5359	1083	3.79		0.8	5472	1038	3.44
	1	5261	1112	3.89		1	5379	1071	3.54
	1.2	5161	1143	4.00		1.2	5282	1102	3.65
	1.4	5022	1174	4.11		1.4	5178	1139	3.77
T6**	0.2	2566	552	0.47	T6**	0.2	2506	525	0.45
	0.4	2299	632	0.54		0.4	-	-	-
	0.6	2034	702	0.60		0.6	-	-	-
	0.8	1869	749	0.64		0.8	-	-	-
	1	1657	800	0.69		1	-	-	-
	1.2	1448	843	0.72		1.2	-	-	-
	1.4	-	-	-		1.4	-	-	-
T7**	0.2	3189	641	0.80	T7**	0.2	3169	610	0.76
	0.4	2975	703	0.88		0.4	3027	671	0.83
	0.6	2765	762	0.95		0.6	2763	745	0.93
	0.8	2611	806	1.00		0.8	2614	796	0.99
	1	-	-	-		1	-	-	-
	1.2	-	-	-		1.2	-	-	-
	1.4	-	-	-		1.4	-	-	-
T8	0.2	3751	722	1.18	T8	0.2	3765	687	1.12
	0.4	3581	770	1.25		0.4	3646	737	1.20
	0.6	3416	819	1.33		0.6	3449	794	1.29
	0.8	3274	860	1.40		0.8	3322	841	1.37
	1	3075	911	1.48		1	3136	894	1.46
	1.2	2917	950	1.55		1.2	2965	943	1.54
	1.4	2664	998	1.63		1.4	2782	987	1.61
T9	0.2	5506	981	3.25	T9	0.2	5591	932	3.09
	0.4	5413	1007	3.33		0.4	5504	961	3.18
	0.6	5331	1034	3.42		0.6	5433	988	3.27
	0.8	5233	1064	3.52		0.8	5352	1020	3.38
	1	5121	1096	3.63		1	5247	1056	3.50
	1.2	5020	1128	3.73		1.2	5145	1089	3.61
	1.4	4861	1162	3.85		1.4	5031	1128	3.73
T10	0.2	5631	1001	3.50	T10	0.2	5717	950	3.15
	0.4	5537	1028	3.60		0.4	5627	979	3.24
	0.6	5452	1054	3.69		0.6	5553	1007	3.33
	0.8	5359	1083	3.79		0.8	5472	1038	3.44
	1	5261	1112	3.89		1	5379	1071	3.54
	1.2	5161	1143	4.00		1.2	5282	1102	3.65
	1.4	5022	1174	4.11		1.4	5178	1139	3.77

Shaded speed tap - Gas heating airflow.
 **(T1) (T2) and (T6)(T7) are part load only.

12.5 Ton Fan Data • 130 MBH Gas Heat Exchange • Models: DSG1503W, DSG1504W, DSG1507W

Down Flow				
Speed Tap	ESP	CFM	RPM	BHP
T1**	0.2	2704	572	0.54
	0.4	-	-	-
	0.6	-	-	-
	0.8	-	-	-
	1	-	-	-
	1.2	-	-	-
	1.4	-	-	-
	1.6	-	-	-
T2**	0.2	2947	606	0.66
	0.4	2713	675	0.74
	0.6	-	-	-
	0.8	-	-	-
	1	-	-	-
	1.2	-	-	-
	1.4	-	-	-
	1.6	-	-	-
T3	0.2	4815	877	2.20
	0.4	4708	905	2.27
	0.6	4609	939	2.36
	0.8	4492	974	2.44
	1	4328	1018	2.56
	1.2	4210	1053	2.64
	1.4	3990	1098	2.76
	1.6	3782	1133	2.84
T4	0.2	5720	1015	3.70
	0.4	5621	1043	3.81
	0.6	5533	1070	3.90
	0.8	5443	1098	4.01
	1	5357	1124	4.10
	1.2	5258	1154	4.21
	1.4	5136	1182	4.31
	1.6	5009	1210	4.41
T5	0.2	5804	1029	3.92
	0.4	5700	1059	4.03
	0.6	5607	1086	4.13
	0.8	5520	1113	4.24
	1	5448	1136	4.33
	1.2	5349	1165	4.44
	1.4	5245	1189	4.53
	1.6	5141	1218	4.64

Horizontal Flow				
Speed Tap	ESP	CFM	RPM	BHP
T1**	0.2	2653	543	0.51
	0.4	-	-	-
	0.6	-	-	-
	0.8	-	-	-
	1	-	-	-
	1.2	-	-	-
	1.4	-	-	-
	1.6	-	-	-
T2**	0.2	2911	577	0.63
	0.4	2759	643	0.70
	0.6	-	-	-
	0.8	-	-	-
	1	-	-	-
	1.2	-	-	-
	1.4	-	-	-
	1.6	-	-	-
T3	0.2	4881	835	2.10
	0.4	4794	868	2.18
	0.6	4695	900	2.26
	0.8	4603	939	2.36
	1	4453	985	2.47
	1.2	4325	1026	2.58
	1.4	4174	1072	2.69
	1.6	3966	1118	2.81
T4	0.2	5805	963	3.51
	0.4	5711	992	3.62
	0.6	5632	1022	3.73
	0.8	5550	1052	3.84
	1	5468	1082	3.95
	1.2	5374	1112	4.06
	1.4	5278	1146	4.18
	1.6	5171	1180	4.30
T5	0.2	5888	975	3.71
	0.4	5788	1006	3.83
	0.6	5703	1038	3.95
	0.8	5619	1067	4.06
	1	5548	1094	4.16
	1.2	5457	1122	4.27
	1.4	5370	1153	4.39
	1.6	5285	1186	4.51

12.5 Ton Fan Data • 130 MBH Gas Heat Exchange • Models: DSG1503W, DSG1504W, DSG1507W

Down Flow				
Speed Tap	ESP	CFM	RPM	BHP
T6**	0.2	1739	435	0.17
	0.4	1397	539	0.22
	0.6	-	-	-
	0.8	-	-	-
	1	-	-	-
	1.2	-	-	-
	1.4	-	-	-
	1.6	-	-	-
	1.8	-	-	-
T7**	0.2	2209	501	0.33
	0.4	1911	591	0.39
	0.6	1612	669	0.44
	0.8	1440	717	0.47
	1	-	-	-
	1.2	-	-	-
	1.4	-	-	-
	1.6	-	-	-
	1.8	-	-	-
T8	0.2	2652	564	0.51
	0.4	2393	641	0.58
	0.6	2136	710	0.65
	0.8	1972	756	0.69
	1	1761	808	0.74
	1.2	1556	850	0.77
	1.4	-	-	-
	1.6	-	-	-
	1.8	-	-	-
T9	0.2	5720	1015	3.70
	0.4	5621	1043	3.81
	0.6	5533	1070	3.90
	0.8	5443	1098	4.01
	1	5357	1124	4.10
	1.2	5258	1154	4.21
	1.4	5136	1182	4.31
	1.6	5009	1210	4.41
	1.8	4856	1244	4.54
T10	0.2	5804	1029	3.92
	0.4	5700	1059	4.03
	0.6	5607	1086	4.13
	0.8	5520	1113	4.24
	1	5448	1136	4.33
	1.2	5349	1165	4.44
	1.4	5245	1189	4.53
	1.6	5141	1218	4.64
	1.8	5009	1247	4.75

Horizontal Flow				
Speed Tap	ESP	CFM	RPM	BHP
T6**	0.2	1623	412	0.16
	0.4	1408	505	0.20
	0.6	-	-	-
	0.8	-	-	-
	1	-	-	-
	1.2	-	-	-
	1.4	-	-	-
	1.6	-	-	-
	1.8	-	-	-
T7**	0.2	2125	476	0.31
	0.4	1936	558	0.37
	0.6	1545	666	0.44
	0.8	1353	723	0.47
	1	-	-	-
	1.2	-	-	-
	1.4	-	-	-
	1.6	-	-	-
	1.8	-	-	-
T8	0.2	2598	536	0.49
	0.4	2431	609	0.55
	0.6	2099	701	0.64
	0.8	1927	755	0.69
	1	1721	810	0.74
	1.2	1505	864	0.79
	1.4	-	-	-
	1.6	-	-	-
	1.8	-	-	-
T9	0.2	5805	963	3.51
	0.4	5711	992	3.62
	0.6	5632	1022	3.73
	0.8	5550	1052	3.84
	1	5468	1082	3.95
	1.2	5374	1112	4.06
	1.4	5278	1146	4.18
	1.6	5171	1180	4.30
	1.8	5045	1214	4.43
T10	0.2	5888	975	3.71
	0.4	5788	1006	3.83
	0.6	5703	1038	3.95
	0.8	5619	1067	4.06
	1	5548	1094	4.16
	1.2	5457	1122	4.27
	1.4	5370	1153	4.39
	1.6	5285	1186	4.51
	1.8	5182	1219	4.64

Shaded speed tap - Gas heating airflow.
 **(T1) (T2) and (T6)(T7) are part load only.

12.5 Ton Fan Data • 180 MBH Gas Heat Exchange • Models: DSG1503D, DSG1504D, DSG1507D

Down Flow				
Speed Tap	ESP	CFM	RPM	BHP
T1**	0.2	2193	557	0.39
	0.4	1887	633	0.45
	0.6	1669	689	0.49
	0.8	1468	736	0.52
T2**	0.2	2471	600	0.53
	0.4	2214	666	0.59
	0.6	2000	721	0.64
	0.8	1783	773	0.68
T3	0.2	4276	902	2.24
	0.4	4194	935	2.32
	0.6	4090	964	2.39
	0.8	3950	999	2.48
T4	0.2	4410	929	2.48
	0.4	4318	963	2.57
	0.6	4236	988	2.64
	0.8	4130	1015	2.71
T5	0.2	4486	944	2.63
	0.4	4384	980	2.73
	0.6	4317	1002	2.79
	0.8	4234	1023	2.85
T6**	0.2	1953	521	0.29
	0.4	-	-	-
	0.6	-	-	-
	0.8	-	-	-
T7**	0.2	2464	599	0.33
	0.4	2206	665	0.37
	0.6	1991	720	0.40
	0.8	-	-	-
T8	0.2	2927	671	0.81
	0.4	2743	724	0.87
	0.6	2538	775	0.93
	0.8	-	-	-
T9	0.2	4410	929	2.48
	0.4	4318	963	2.57
	0.6	4236	988	2.64
	0.8	4130	1015	2.71
T10	0.2	4486	944	2.63
	0.4	4384	980	2.73
	0.6	4317	1002	2.79
	0.8	4234	1023	2.85

Horizontal Flow				
Speed Tap	ESP	CFM	RPM	BHP
T1**	0.2	2396	493	0.35
	0.4	2214	572	0.40
	0.6	1870	666	0.47
	0.8	1703	718	0.51
T2**	0.2	2687	529	0.47
	0.4	2527	601	0.53
	0.6	2243	684	0.61
	0.8	2086	736	0.65
T3	0.2	4645	783	1.94
	0.4	4562	820	2.04
	0.6	4489	860	2.14
	0.8	4400	902	2.24
T4	0.2	4802	805	2.15
	0.4	4715	841	2.25
	0.6	4629	883	2.36
	0.8	4545	921	2.46
T5	0.2	4892	818	2.28
	0.4	4801	854	2.38
	0.6	4703	897	2.50
	0.8	4623	933	2.60
T6**	0.2	2147	462	0.26
	0.4	1944	548	0.31
	0.6	-	-	-
	0.8	-	-	-
T7**	0.2	2680	528	0.29
	0.4	2519	601	0.33
	0.6	2234	684	0.38
	0.8	2076	736	0.41
T8	0.2	3168	589	0.71
	0.4	3039	651	0.79
	0.6	2844	717	0.87
	0.8	2703	769	0.93
T9	0.2	4802	805	2.15
	0.4	4715	841	2.25
	0.6	4629	883	2.36
	0.8	4545	921	2.46
T10	0.2	4892	818	2.28
	0.4	4801	854	2.38
	0.6	4703	897	2.50
	0.8	4623	933	2.60

Shaded speed tap - Gas heating airflow.
 **(T1) (T2) and (T6)(T7) are part load only.

12.5 Ton Fan Data • 180 MBH Gas Heat Exchange • Models: DSG1503L, DSG1504L, DSG1507L

Down Flow					Horizontal Flow				
Speed Tap	ESP	CFM	RPM	BHP	Speed Tap	ESP	CFM	RPM	BHP
T1**	0.2	2460	566	0.49	T1**	0.2	2601	527	0.45
	0.4	2245	640	0.55		0.4	2405	600	0.52
	0.6	1998	704	0.61		0.6	2146	679	0.58
	0.8	1829	749	0.64		0.8	1920	747	0.64
	1	1623	796	0.68		1	1759	793	0.68
	1.2	1451	851	0.73		1.2	1506	863	0.74
	1.4	-	-	-		1.4	1410	906	0.78
T2**	0.2	2715	603	0.61	T2**	0.2	2859	560	0.56
	0.4	2518	671	0.68		0.4	2677	627	0.63
	0.6	2289	731	0.74		0.6	2444	701	0.71
	0.8	2123	775	0.78		0.8	2235	765	0.77
	1	1918	822	0.83		1	2078	811	0.82
	1.2	1748	873	0.88		1.2	1835	880	0.89
	1.4	1547	911	0.92		1.4	1732	921	0.93
T3	0.2	4558	880	2.05	T3	0.2	4729	802	1.87
	0.4	4466	910	2.12		0.4	4634	839	1.95
	0.6	4344	944	2.20		0.6	4543	874	2.03
	0.8	4202	979	2.28		0.8	4440	916	2.13
	1	4028	1020	2.37		1	4319	957	2.23
	1.2	3881	1050	2.44		1.2	4161	1013	2.36
	1.4	3699	1093	2.54		1.4	4030	1044	2.43
T4	0.2	5562	1041	3.63	T4	0.2	5756	944	3.29
	0.4	5487	1067	3.72		0.4	5672	974	3.40
	0.6	5385	1092	3.81		0.6	5597	1003	3.50
	0.8	5265	1121	3.91		0.8	5519	1035	3.61
	1	5139	1150	4.01		1	5427	1069	3.73
	1.2	5008	1175	4.10		1.2	5333	1101	3.84
	1.4	4883	1208	4.22		1.4	5236	1131	3.95
T5	0.2	5665	1058	3.88	T5	0.2	5862	960	3.52
	0.4	5586	1086	3.98		0.4	5775	990	3.63
	0.6	5481	1111	4.08		0.6	5692	1021	3.75
	0.8	5364	1140	4.18		0.8	5612	1052	3.86
	1	5247	1166	4.28		1	5526	1084	3.98
	1.2	5119	1192	4.37		1.2	5440	1112	4.08
	1.4	5005	1222	4.48		1.4	5353	1143	4.19
T6**	0.2	2809	617	0.66	T6**	0.2	2955	572	0.61
	0.4	2618	683	0.73		0.4	2778	638	0.68
	0.6	2396	741	0.79		0.6	2553	709	0.75
	0.8	2231	785	0.84		0.8	2350	772	0.82
	1	2026	831	0.89		1	2195	817	0.87
	1.2	1858	882	0.94		1.2	1956	887	0.94
	1.4	1657	920	0.98		1.4	1851	927	0.99
T7**	0.2	3566	730	1.13	T7**	0.2	3722	670	1.04
	0.4	3424	778	1.21		0.4	3585	722	1.12
	0.6	3249	825	1.28		0.6	3426	776	1.20
	0.8	3093	865	1.34		0.8	3271	829	1.29
	1	2898	910	1.41		1	3129	874	1.36
	1.2	2738	951	1.48		1.2	2923	939	1.46
	1.4	2539	993	1.54		1.4	2800	975	1.51
T8	0.2	4220	829	1.69	T8	0.2	4386	757	1.54
	0.4	4114	864	1.76		0.4	4278	798	1.63
	0.6	3975	902	1.84		0.6	4168	839	1.71
	0.8	3829	939	1.91		0.8	4049	884	1.80
	1	3645	982	2.00		1	3920	927	1.89
	1.2	3494	1015	2.07		1.2	3744	987	2.01
	1.4	3303	1058	2.16		1.4	3614	1020	2.08
T9	0.2	5562	1041	3.63	T9	0.2	5756	944	3.29
	0.4	5487	1067	3.72		0.4	5672	974	3.40
	0.6	5385	1092	3.81		0.6	5597	1003	3.50
	0.8	5265	1121	3.91		0.8	5519	1035	3.61
	1	5139	1150	4.01		1	5427	1069	3.73
	1.2	5008	1175	4.10		1.2	5333	1101	3.84
	1.4	4883	1208	4.22		1.4	5236	1131	3.95
T10	0.2	5665	1058	3.88	T10	0.2	5862	960	3.52
	0.4	5586	1086	3.98		0.4	5775	990	3.63
	0.6	5481	1111	4.08		0.6	5692	1021	3.75
	0.8	5364	1140	4.18		0.8	5612	1052	3.86
	1	5247	1166	4.28		1	5526	1084	3.98
	1.2	5119	1192	4.37		1.2	5440	1112	4.08
	1.4	5005	1222	4.48		1.4	5353	1143	4.19

Shaded speed tap - Gas heating airflow.
 **(T1) (T2) and (T6)(T7) are part load only.

12.5 Ton Fan Data • 180 MBH Gas Heat Exchange • Models: DSG1503W, DSG1504W, DSG1507W

Down Flow				
Speed Tap	ESP	CFM	RPM	BHP
T1**	0.2	2636	592	0.57
	0.4	2434	661	0.64
	0.6	2200	723	0.70
	0.8	2033	767	0.74
	1	1827	814	0.8
	1.2	1657	866	0.8
	1.4	1456	904	0.9
	1.6	-	-	-
T2**	0.2	2868	626	0.69
	0.4	2682	690	0.76
	0.6	2463	748	0.82
	0.8	2299	791	0.87
	1	2095	838	0.92
	1.2	1927	887	0.98
	1.4	1726	926	1.02
	1.6	1468	998	1.10
T3	0.2	4839	924	2.40
	0.4	4758	951	2.46
	0.6	4646	982	2.54
	0.8	4510	1015	2.63
	1	4345	1054	2.73
	1.2	4202	1081	2.80
	1.4	4029	1123	2.91
	1.6	3885	1146	2.97
T4	0.2	5692	1063	3.95
	0.4	5611	1092	4.06
	0.6	5505	1117	4.15
	0.8	5389	1145	4.26
	1	5275	1170	4.35
	1.2	5147	1197	4.45
	1.4	5038	1226	4.56
	1.6	4884	1248	4.64
T5	0.2	5813	1085	4.32
	0.4	5722	1118	4.46
	0.6	5608	1143	4.56
	0.8	5497	1171	4.67
	1	5398	1192	4.75
	1.2	5274	1220	4.86
	1.4	5184	1244	4.96
	1.6	5015	1271	5.07
1.8	4884	1282	5.11	

Horizontal Flow				
Speed Tap	ESP	CFM	RPM	BHP
T1**	0.2	2780	550	0.53
	0.4	2594	619	0.60
	0.6	2353	694	0.67
	0.8	2138	760	0.73
	1	1980	805	0.77
	1.2	1734	875	0.84
	1.4	1633	916	0.88
	1.6	1417	969	0.93
T2**	0.2	3015	580	0.64
	0.4	2841	644	0.71
	0.6	2622	714	0.79
	0.8	2423	776	0.85
	1	2269	822	0.90
	1.2	2032	891	0.98
	1.4	1925	931	1.02
	1.6	1704	985	1.08
T3	0.2	5016	841	2.18
	0.4	4928	874	2.27
	0.6	4851	906	2.35
	0.8	4759	944	2.45
	1	4645	984	2.55
	1.2	4503	1036	2.68
	1.4	4375	1066	2.76
	1.6	4176	1120	2.90
T4	0.2	5890	964	3.59
	0.4	5801	995	3.70
	0.6	5716	1026	3.82
	0.8	5636	1057	3.93
	1	5550	1089	4.05
	1.2	5467	1115	4.15
	1.4	5383	1146	4.26
	1.6	5301	1178	4.38
T5	0.2	6016	984	3.92
	0.4	5919	1017	4.05
	0.6	5818	1052	4.19
	0.8	5731	1081	4.31
	1	5652	1111	4.43
	1.2	5582	1129	4.50
	1.4	5516	1162	4.63
	1.6	5473	1186	4.73
1.8	5380	1223	4.88	

12.5 Ton Fan Data • 180 MBH Gas Heat Exchange • Models: DSG1503W, DSG1504W, DSG1507W

Down Flow				
Speed Tap	ESP	CFM	RPM	BHP
T6**	0.2	2893	630	0.70
	0.4	2709	693	0.77
	0.6	-	-	-
	0.8	-	-	-
	1	-	-	-
	1.2	-	-	-
	1.4	-	-	-
	1.6	-	-	-
	1.8	-	-	-
T7**	0.2	3491	719	1.08
	0.4	3344	768	1.15
	0.6	3165	817	1.23
	0.8	3009	857	1.29
	1	2812	903	1.35
	1.2	2652	944	1.42
	1.4	-	-	-
	1.6	-	-	-
	1.8	-	-	-
T8	0.2	4636	893	2.14
	0.4	4548	921	2.21
	0.6	4429	955	2.29
	0.8	4289	989	2.37
	1	4117	1030	2.47
	1.2	3971	1058	2.54
	1.4	3791	1101	2.64
	1.6	3641	1127	2.70
	1.8	3419	1170	2.80
T9	0.2	5692	1063	3.95
	0.4	5611	1092	4.06
	0.6	5505	1117	4.15
	0.8	5389	1145	4.26
	1	5275	1170	4.35
	1.2	5147	1197	4.45
	1.4	5038	1226	4.56
	1.6	4884	1248	4.64
	1.8	4725	1269	4.72
T10	0.2	5813	1085	4.32
	0.4	5722	1118	4.46
	0.6	5608	1143	4.56
	0.8	5497	1171	4.67
	1	5398	1192	4.75
	1.2	5274	1220	4.86
	1.4	5184	1244	4.96
	1.6	5015	1271	5.07
	1.8	4884	1282	5.11

Horizontal Flow				
Speed Tap	ESP	CFM	RPM	BHP
T6**	0.2	3040	583	0.65
	0.4	2868	647	0.72
	0.6	2651	716	0.80
	0.8	-	-	-
	1	-	-	-
	1.2	-	-	-
	1.4	-	-	-
	1.6	-	-	-
	1.8	-	-	-
T7**	0.2	3646	661	0.99
	0.4	3505	714	1.07
	0.6	3341	769	1.15
	0.8	3181	823	1.24
	1	3038	868	1.30
	1.2	2828	934	1.40
	1.4	2706	970	1.46
	1.6	2476	1028	1.54
	1.8	2286	1085	1.63
T8	0.2	4810	813	1.95
	0.4	4716	849	2.04
	0.6	4630	883	2.12
	0.8	4530	923	2.21
	1	4411	964	2.31
	1.2	4257	1019	2.44
	1.4	4127	1050	2.52
	1.6	3916	1107	2.65
	1.8	3765	1143	2.74
T9	0.2	5890	964	3.59
	0.4	5801	995	3.70
	0.6	5716	1026	3.82
	0.8	5636	1057	3.93
	1	5550	1089	4.05
	1.2	5467	1115	4.15
	1.4	5383	1146	4.26
	1.6	5301	1178	4.38
	1.8	5199	1212	4.51
T10	0.2	6016	984	3.92
	0.4	5919	1017	4.05
	0.6	5818	1052	4.19
	0.8	5731	1081	4.31
	1	5652	1111	4.43
	1.2	5582	1129	4.50
	1.4	5516	1162	4.63
	1.6	5473	1186	4.73
	1.8	5380	1223	4.88

Shaded speed tap - Gas heating airflow.
 **(T1) (T2) and (T6)(T7) are part load only.

12.5 Ton Fan Data • 240 MBH Gas Heat Exchange • Models: DSG1503D, DSG1504D, DSG1507D

Down Flow				
Speed Tap	ESP	CFM	RPM	BHP
T1**	0.2	2201	591	0.45
	0.4	1963	656	0.50
	0.6	1757	707	0.54
	0.8	1557	750	0.57
T2**	0.2	2378	617	0.54
	0.4	2159	678	0.60
	0.6	1952	730	0.64
	0.8	1745	776	0.68
T3	0.2	4170	910	2.26
	0.4	4067	938	2.33
	0.6	3941	974	2.42
	0.8	3784	1010	2.51
T4	0.2	4268	929	2.44
	0.4	4162	956	2.51
	0.6	4051	988	2.59
	0.8	3913	1020	2.67
T5	0.2	4371	951	2.65
	0.4	4259	977	2.72
	0.6	4168	1003	2.79
	0.8	4054	1028	2.86
T6**	0.2	2714	668	0.74
	0.4	2528	721	0.80
	0.6	-	-	-
	0.8	-	-	-
T7**	0.2	3440	782	0.87
	0.4	3314	820	0.91
	0.6	3126	872	0.97
	0.8	2907	924	1.03
T8	0.2	4006	879	2.00
	0.4	3903	908	2.07
	0.6	3756	950	2.16
	0.8	3576	993	2.26
T9	0.2	4268	929	2.44
	0.4	4162	956	2.51
	0.6	4051	988	2.59
	0.8	3913	1020	2.67
T10	0.2	4371	951	2.65
	0.4	4259	977	2.72
	0.6	4168	1003	2.79
	0.8	4054	1028	2.86

Horizontal Flow				
Speed Tap	ESP	CFM	RPM	BHP
T1**	0.2	2476	505	0.39
	0.4	2292	578	0.44
	0.6	1965	670	0.51
	0.8	1791	722	0.55
T2**	0.2	2659	527	0.46
	0.4	2489	596	0.53
	0.6	2199	680	0.60
	0.8	2035	733	0.65
T3	0.2	4604	774	1.92
	0.4	4518	814	2.02
	0.6	4442	853	2.12
	0.8	4348	895	2.22
T4	0.2	4722	790	2.07
	0.4	4634	830	2.18
	0.6	4549	870	2.28
	0.8	4458	910	2.39
T5	0.2	4849	808	2.25
	0.4	4757	848	2.36
	0.6	4656	891	2.48
	0.8	4566	928	2.58
T6**	0.2	3008	570	0.63
	0.4	2862	632	0.70
	0.6	2640	702	0.78
	0.8	-	-	-
T7**	0.2	3781	666	0.74
	0.4	3677	715	0.80
	0.6	3569	762	0.85
	0.8	3451	812	0.90
T8	0.2	4412	748	1.70
	0.4	4326	790	1.80
	0.6	4255	828	1.88
	0.8	4157	872	1.98
T9	0.2	4722	790	2.07
	0.4	4634	830	2.18
	0.6	4549	870	2.28
	0.8	4458	910	2.39
T10	0.2	4849	808	2.25
	0.4	4757	848	2.36
	0.6	4656	891	2.48
	0.8	4566	928	2.58

Shaded speed tap - Gas heating airflow.
 **(T1) (T2) and (T6)(T7) are part load only.

12.5 Ton Fan Data • 240 MBH Gas Heat Exchange • Models: DSG1503L, DSG1504L, DSG1507L

Down Flow					Horizontal Flow				
Speed Tap	ESP	CFM	RPM	BHP	Speed Tap	ESP	CFM	RPM	BHP
T1**	0.2	2551	625	0.60	T1**	0.2	2756	547	0.53
	0.4	2345	687	0.66		0.4	2597	613	0.59
	0.6	2139	741	0.71		0.6	2292	707	0.68
	0.8	1985	786	0.76		0.8	2146	758	0.73
	1	1804	845	0.81		1	1968	810	0.78
	1.2	1670	884	0.85		1.2	1759	865	0.83
	1.4	1432	952	0.92		1.4	1574	896	0.86
T2**	0.2	2682	647	0.68	T2**	0.2	2896	565	0.59
	0.4	2484	706	0.74		0.4	2742	629	0.66
	0.6	2284	758	0.79		0.6	2455	718	0.75
	0.8	2132	802	0.84		0.8	2313	768	0.80
	1	1953	860	0.90		1	2135	820	0.86
	1.2	1817	898	0.94		1.2	1933	875	0.91
	1.4	1583	963	1.01		1.4	1749	908	0.95
T3	0.2	4560	959	2.40	T3	0.2	4898	828	2.07
	0.4	4456	983	2.46		0.4	4805	863	2.16
	0.6	4332	1015	2.54		0.6	4717	894	2.23
	0.8	4209	1048	2.62		0.8	4624	933	2.33
	1	4064	1081	2.70		1	4488	981	2.45
	1.2	3916	1111	2.78		1.2	4370	1024	2.56
	1.4	3749	1141	2.85		1.4	4229	1071	2.68
T4	0.2	5492	1121	4.20	T4	0.2	5877	971	3.64
	0.4	5399	1146	4.29		0.4	5792	999	3.74
	0.6	5306	1171	4.39		0.6	5711	1030	3.86
	0.8	5185	1195	4.48		0.8	5632	1061	3.97
	1	5083	1218	4.56		1	5564	1089	4.08
	1.2	4962	1240	4.65		1.2	5480	1118	4.19
	1.4	4836	1260	4.72		1.4	5393	1150	4.31
T5	0.2	5600	1141	4.55	T5	0.2	5989	990	3.95
	0.4	5503	1169	4.66		0.4	5900	1018	4.06
	0.6	5412	1194	4.76		0.6	5803	1055	4.20
	0.8	5289	1216	4.85		0.8	5723	1084	4.32
	1	5197	1239	4.94		1	5672	1107	4.41
	1.2	5084	1260	5.02		1.2	5591	1133	4.52
	1.4	4965	1280	5.10		1.4	5516	1159	4.62
T6**	0.2	3326	753	1.11	T6**	0.2	3585	653	0.96
	0.4	3165	798	1.18		0.4	3454	707	1.04
	0.6	2992	842	1.24		0.6	3247	772	1.14
	0.8	2851	883	1.30		0.8	3124	819	1.21
	1	2681	932	1.37		1	2954	872	1.29
	1.2	2536	968	1.43		1.2	2781	923	1.36
	1.4	-	-	-		1.4	2609	964	1.42
T7**	0.2	4117	885	1.85	T7**	0.2	4428	764	1.60
	0.4	3995	915	1.91		0.4	4323	805	1.68
	0.6	3854	951	1.99		0.6	4199	846	1.77
	0.8	3726	987	2.06		0.8	4097	888	1.86
	1	3570	1025	2.14		1	3945	939	1.96
	1.2	3421	1057	2.21		1.2	3808	986	2.06
	1.4	3237	1095	2.29		1.4	3653	1033	2.16
T8	0.2	4756	992	2.68	T8	0.2	5106	857	2.32
	0.4	4658	1015	2.75		0.4	5017	889	2.41
	0.6	4542	1045	2.83		0.6	4940	917	2.48
	0.8	4420	1076	2.91		0.8	4851	955	2.58
	1	4282	1107	2.99		1	4724	1001	2.71
	1.2	4136	1135	3.07		1.2	4615	1041	2.82
	1.4	3977	1163	3.15		1.4	4482	1088	2.94
T9	0.2	5492	1121	4.20	T9	0.2	5877	971	3.64
	0.4	5399	1146	4.29		0.4	5792	999	3.74
	0.6	5306	1171	4.39		0.6	5711	1030	3.86
	0.8	5185	1195	4.48		0.8	5632	1061	3.97
	1	5083	1218	4.56		1	5564	1089	4.08
	1.2	4962	1240	4.65		1.2	5480	1118	4.19
	1.4	4836	1260	4.72		1.4	5393	1150	4.31
T10	0.2	5600	1141	4.55	T10	0.2	5989	990	3.95
	0.4	5503	1169	4.66		0.4	5900	1018	4.06
	0.6	5412	1194	4.76		0.6	5803	1055	4.20
	0.8	5289	1216	4.85		0.8	5723	1084	4.32
	1	5197	1239	4.94		1	5672	1107	4.41
	1.2	5084	1260	5.02		1.2	5591	1133	4.52
	1.4	4965	1280	5.10		1.4	5516	1159	4.62

Shaded speed tap - Gas heating airflow.
 **(T1) (T2) and (T6)(T7) are part load only.

12.5 Ton Fan Data • 240 MBH Gas Heat Exchange • Models: DSG1503W, DSG1504W, DSG1507W

Down Flow				
Speed Tap	ESP	CFM	RPM	BHP
T1**	0.2	2551	625	0.60
	0.4	2345	687	0.66
	0.6	2139	741	0.71
	0.8	1985	786	0.76
	1	1804	845	0.81
	1.2	1670	884	0.85
	1.4	1432	952	0.92
	1.6	-	-	-
T2**	0.2	2826	671	0.76
	0.4	2637	726	0.83
	0.6	2443	776	0.88
	0.8	2294	820	0.93
	1	2116	876	1.00
	1.2	1978	913	1.04
	1.4	1749	976	1.11
	1.6	1596	1005	1.14
T3	0.2	4825	1004	2.79
	0.4	4729	1026	2.85
	0.6	4615	1056	2.94
	0.8	4495	1086	3.02
	1	4359	1116	3.11
	1.2	4214	1144	3.18
	1.4	4057	1171	3.26
	1.6	3852	1206	3.36
T4	0.2	5509	1124	4.25
	0.4	5416	1149	4.35
	0.6	5323	1174	4.44
	0.8	5202	1198	4.53
	1	5102	1221	4.62
	1.2	4982	1243	4.70
	1.4	4857	1263	4.78
	1.6	4731	1284	4.86
T5	0.2	5600	1141	4.55
	0.4	5503	1169	4.66
	0.6	5412	1194	4.76
	0.8	5289	1216	4.85
	1	5197	1239	4.94
	1.2	5084	1260	5.02
	1.4	4965	1280	5.10
	1.6	4866	1296	5.17

Horizontal Flow				
Speed Tap	ESP	CFM	RPM	BHP
T1**	0.2	2756	547	0.53
	0.4	2597	613	0.59
	0.6	2292	707	0.68
	0.8	2146	758	0.73
	1	1968	810	0.78
	1.2	1759	865	0.83
	1.4	1574	896	0.86
	1.6	1422	968	0.93
T2**	0.2	3051	585	0.66
	0.4	2902	646	0.73
	0.6	2633	729	0.83
	0.8	2496	779	0.89
	1	2319	832	0.95
	1.2	2123	886	1.01
	1.4	1942	920	1.05
	1.6	1780	989	1.12
T3	0.2	5179	867	2.41
	0.4	5091	899	2.50
	0.6	5018	926	2.58
	0.8	4930	963	2.68
	1	4807	1008	2.80
	1.2	4700	1048	2.92
	1.4	4570	1094	3.04
	1.6	4405	1136	3.16
T4	0.2	5896	974	3.68
	0.4	5810	1002	3.79
	0.6	5727	1034	3.91
	0.8	5647	1065	4.03
	1	5582	1092	4.13
	1.2	5499	1120	4.24
	1.4	5413	1152	4.36
	1.6	5332	1185	4.48
T5	0.2	5989	990	3.95
	0.4	5900	1018	4.06
	0.6	5803	1055	4.20
	0.8	5723	1084	4.32
	1	5672	1107	4.41
	1.2	5591	1133	4.52
	1.4	5516	1159	4.62
	1.6	5460	1191	4.75

12.5 Ton Fan Data • 240 MBH Gas Heat Exchange • Models: DSG1503W, DSG1504W, DSG1507W

Down Flow				
Speed Tap	ESP	CFM	RPM	BHP
T6**	0.2	3028	704	0.89
	0.4	2851	755	0.96
	0.6	2665	803	1.02
	0.8	2520	845	1.07
	1	-	-	-
	1.2	-	-	-
	1.4	-	-	-
	1.6	-	-	-
	1.8	-	-	-
T7**	0.2	4234	904	1.98
	0.4	4117	933	2.04
	0.6	3981	968	2.12
	0.8	3854	1003	2.20
	1	3701	1040	2.28
	1.2	3552	1071	2.35
	1.4	3372	1107	2.43
	1.6	3160	1144	2.51
	1.8	2978	1177	2.58
T8	0.2	5098	1051	3.27
	0.4	5007	1072	3.34
	0.6	4903	1100	3.43
	0.8	4783	1128	3.51
	1	4658	1155	3.60
	1.2	4519	1181	3.68
	1.4	4374	1204	3.75
	1.6	4186	1236	3.85
	1.8	4026	1266	3.94
T9	0.2	5509	1124	4.25
	0.4	5416	1149	4.35
	0.6	5323	1174	4.44
	0.8	5202	1198	4.53
	1	5102	1221	4.62
	1.2	4982	1243	4.70
	1.4	4857	1263	4.78
	1.6	4731	1284	4.86
	1.8	4590	1304	4.93
T10	0.2	5600	1141	4.55
	0.4	5503	1169	4.66
	0.6	5412	1194	4.76
	0.8	5289	1216	4.85
	1	5197	1239	4.94
	1.2	5084	1260	5.02
	1.4	4965	1280	5.10
	1.6	4866	1296	5.17
	1.8	4731	1311	5.23

Horizontal Flow				
Speed Tap	ESP	CFM	RPM	BHP
T6**	0.2	3267	612	0.78
	0.4	3126	671	0.85
	0.6	2883	746	0.95
	0.8	2751	795	1.01
	1	2577	848	1.08
	1.2	-	-	-
	1.4	-	-	-
	1.6	-	-	-
	1.8	-	-	-
T7**	0.2	4552	781	1.71
	0.4	4451	820	1.80
	0.6	4338	858	1.88
	0.8	4238	900	1.97
	1	4089	950	2.08
	1.2	3957	996	2.18
	1.4	3806	1043	2.29
	1.6	3622	1093	2.40
	1.8	3434	1143	2.51
T8	0.2	5466	908	2.83
	0.4	5382	937	2.92
	0.6	5316	963	3.00
	0.8	5233	998	3.11
	1	5127	1038	3.23
	1.2	5031	1074	3.35
	1.4	4914	1117	3.48
	1.6	4770	1156	3.60
	1.8	4605	1198	3.73
T9	0.2	5896	974	3.68
	0.4	5810	1002	3.79
	0.6	5727	1034	3.91
	0.8	5647	1065	4.03
	1	5582	1092	4.13
	1.2	5499	1120	4.24
	1.4	5413	1152	4.36
	1.6	5332	1185	4.48
	1.8	5240	1219	4.61
T10	0.2	5989	990	3.95
	0.4	5900	1018	4.06
	0.6	5803	1055	4.20
	0.8	5723	1084	4.32
	1	5672	1107	4.41
	1.2	5591	1133	4.52
	1.4	5516	1159	4.62
	1.6	5460	1191	4.75
	1.8	5400	1222	4.87

Shaded speed tap - Gas heating airflow.
 **(T1) (T2) and (T6)(T7) are part load only.

7.5 - 8.5 Ton blower Fan Curve

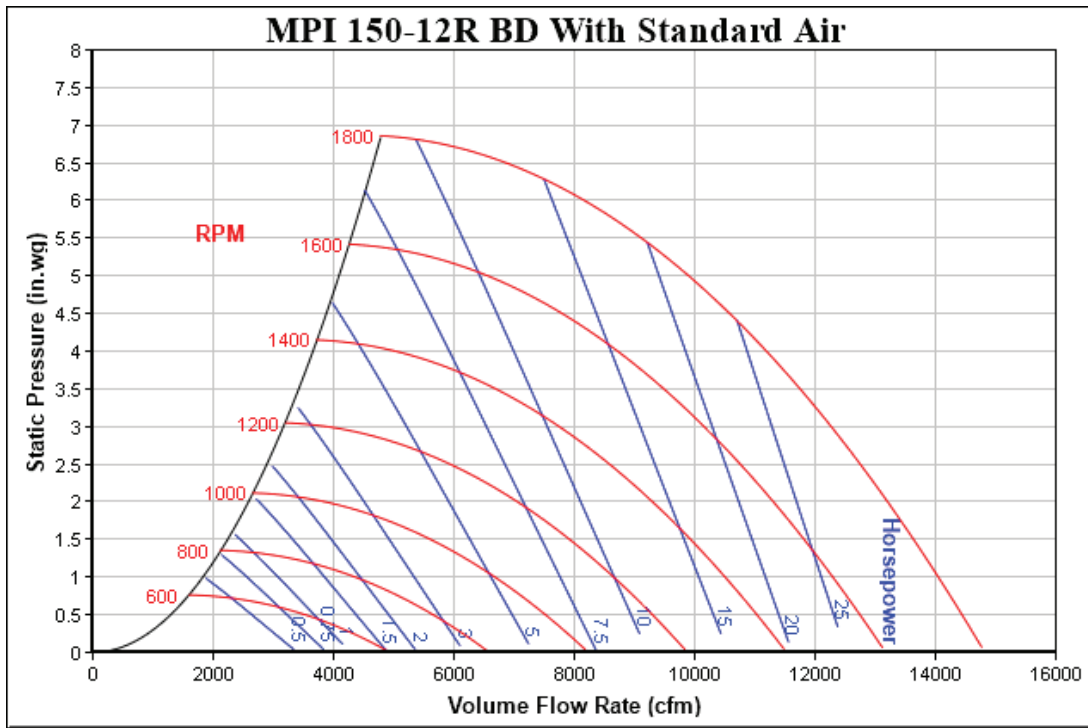

10 - 12.5 Ton blower Fan Curve

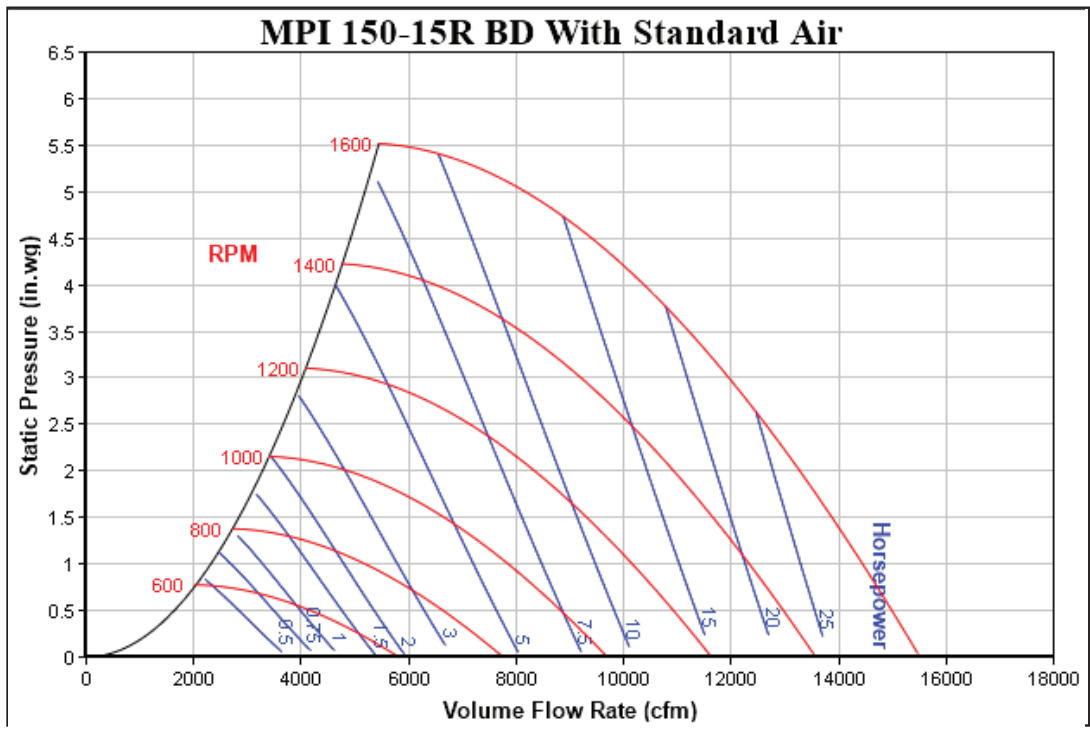

Static Pressure

7.5-12.5 TONS		
DOWNFLOW ECONOMIZER PRESSURE DROP		
Cabinet	CFM	SP in.wg.
7.5 Ton	2250	.04"
	3000	.07"
	3750	.11"
8.5 Ton	2550	.06"
	3400	.10"
	4250	.16"
10 Ton	3000	.08"
	4000	.13"
	5000	.22"
12.5 Ton	3750	.14"
	5000	.24"
	6250	.36"

7.5-12.5 TONS		
HORIZONTAL ECONOMIZER PRESSURE DROP		
Cabinet	CFM	SP in.wg.
7.5 Ton	2250	.05"
	3000	.07"
	3750	.13"
8.5 Ton	2550	.07"
	3400	.13"
	4250	.18"
10 Ton	3000	.07"
	4000	.12"
	5000	.19"
12.5 Ton	3750	.09"
	5000	.15"
	6250	.24"

Electrical Data

Model Number	Electrical Rating	Compressor			Outdoor Fan Motor			Indoor Fan Motor			Optional Powered Convenience Outlet	Optional Power Exhaust	Power Supply	
		QTY	RLA	LRA	QTY	HP	FLA	Type	HP	FLA	FLA	FLA	MCA	MOP
DSG0903D	208/230/3/60	2	12.2	120	2	0.33	2.0	1	2.4	8.0	-	-	39.4/39.4	50/50
											9.6/8.7	-	49.0/48.1	60/60
											-	3.3/3.0 (2.4)	42.7/42.4	50/50
											9.6/8.7	3.3/3.0 (2.4)	52.3/51.1	60/60
DSG0903L	208/230/3/60	2	12.2	120	2	0.33	2.0	1	2.4	8.0	-	-	39.4/39.4	50/50
											9.6/8.7	-	49.0/48.1	60/60
											-	3.3/3.0 (2.4)	42.7/42.4	50/50
											9.6/8.7	3.3/3.0 (2.4)	52.3/51.1	60/60
DSG0903W	208/230/3/60	2	12.2	120	2	0.33	2.0	1	3.5	10.9	-	-	42.3/42.3	50/50
											9.6/8.7	-	51.9/51.0	60/60
											-	3.3/3.0 (2.4)	45.6/45.3	50/50
											9.6/8.7	3.3/3.0 (2.4)	55.2/54.0	60/60
DSG0904D	460/3/60	2	5.8	55.1	2	0.33	0.85	1	2.4	5.4	-	-	20.1	25
											4.3	-	24.4	30
											-	1.2 (1.0)	21.3	25
											4.3	1.2 (1.0)	25.6	30
DSG0904L	460/3/60	2	5.8	55.1	2	0.33	0.85	1	2.4	5.4	-	-	20.1	25
											4.3	-	24.4	30
											-	1.2 (1.0)	21.3	25
											4.3	1.2 (1.0)	25.6	30
DSG0904W	460/3/60	2	5.8	55.1	2	0.33	0.85	1	3.5	7.2	-	-	21.9	25
											4.3	-	26.2	30
											-	1.2 (1.0)	23.1	30
											4.3	1.2 (1.0)	27.4	30
DSG0907D	575/3/60	2	5.8	41.0	2	0.33	0.67	1	2.4	4.0	-	-	18.3	20
											3.5	-	21.8	25
											-	1.3	19.6	25
											3.5	1.3	23.1	25
DSG0907L	575/3/60	2	5.8	41.0	2	0.33	0.67	1	2.4	4.0	-	-	18.3	20
											3.5	-	21.8	25
											-	1.3	19.6	25
											3.5	1.3	23.1	25
DSG0907W	575/3/60	2	5.8	41.0	2	0.33	0.67	1	3.5	5.0	-	-	19.3	25
											3.5	-	22.8	25
											-	1.3	20.6	25
											3.5	1.3	24.1	25
DSG1023D	208/230/3/60	2	14.1	120	2	0.33	2.0	1	2.4	8.0	-	-	43.7/43.7	50/50
											9.6/8.7	-	53.3/52.4	60/60
											-	3.3/3.0 (2.4)	47.0/46.7	60/60
											9.6/8.7	3.3/3.0 (2.4)	56.6/55.4	60/60
DSG1023L	208/230/3/60	2	14.1	120	2	0.33	2.0	1	3.5	10.9	-	-	46.6/46.6	60/60
											9.6/8.7	-	56.2/55.3	70/60
											-	3.3/3.0 (2.4)	49.9/49.6	60/60
											9.6/8.7	3.3/3.0 (2.4)	59.5/58.3	70/70
DSG1023W	208/230/3/60	2	14.1	120	2	0.33	2.0	1	3.5	10.9	-	-	46.6/46.6	60/60
											9.6/8.7	-	56.2/55.3	70/60
											-	3.3/3.0 (2.4)	49.9/49.6	60/60
											9.6/8.7	3.3/3.0 (2.4)	59.5/58.3	70/70

Electrical Data

Model Number	Electrical Rating	Compressor			Outdoor Fan Motor			Indoor Fan Motor			Optional Powered Convenience Outlet	Optional Power Exhaust	Power Supply	
		QTY	RLA	LRA	QTY	HP	FLA	Type	HP	FLA	FLA	FLA	MCA	MOP
DSG1024D	460/3/60	2	6.4	55.1	2	0.33	0.85	1	2.4	5.4	-	-	21.5	25
											4.3	-	25.8	30
											-	1.2 (1.0)	22.7	25
											4.3	1.2 (1.0)	27.0	30
DSG1024L	460/3/60	2	6.4	55.1	2	0.33	0.85	1	3.5	7.2	-	-	23.3	30
											4.3	-	27.6	35
											-	1.2 (1.0)	24.5	30
											4.3	1.2 (1.0)	28.8	35
DSG1024W	460/3/60	2	6.4	55.1	2	0.33	0.85	1	3.5	7.2	-	-	23.3	30
											4.3	-	27.6	35
											-	1.2 (1.0)	24.5	30
											4.3	1.2 (1.0)	28.8	35
DSG1027D	575/3/60	2	5.1	41.0	2	0.33	0.67	1	2.4	4.0	-	-	16.9	20
											3.5	-	20.4	25
											-	1.3	18.2	20
											3.5	1.3	21.7	25
DSG1027L	575/3/60	2	5.1	41.0	2	0.33	0.67	1	3.5	5.0	-	-	17.9	20
											3.5	-	21.4	25
											-	1.3	19.2	20
											3.5	1.3	22.7	25
DSG1027W	575/3/60	2	5.1	41.0	2	0.33	0.67	1	3.5	5.0	-	-	17.9	20
											3.5	-	21.4	25
											-	1.3	19.2	20
											3.5	1.3	22.7	25
DSG1203D	208/230/3/60	2	17.3	155	2	0.33	2.0	1	3.5	10.9	-	-	53.8/53.8	70/70
											9.6/8.7	-	63.4/62.5	80/70
											-	3.3/3.0 (2.4)	57.1/56.8	70/70
											9.6/8.7	3.3/3.0 (2.4)	66.7/65.5	80/80
DSG1203L	208/230/3/60	2	17.3	155	2	0.33	2.0	1	5.0	14.5	-	-	57.4/57.4	70/70
											9.6/8.7	-	67.0/66.1	80/80
											-	3.3/3.0 (2.4)	60.7/60.4	70/70
											9.6/8.7	3.3/3.0 (2.4)	70.3/69.1	80/80
DSG1203W	208/230/3/60	2	17.3	155	2	0.33	2.0	1	5.0	14.5	-	-	57.4/57.4	70/70
											9.6/8.7	-	67.0/66.1	80/80
											-	3.3/3.0 (2.4)	60.7/60.4	70/70
											9.6/8.7	3.3/3.0 (2.4)	70.3/69.1	80/80
DSG1204D	460/3/60	2	7.7	58.1	2	0.33	0.85	1	3.5	7.2	-	-	26.2	30
											4.3	-	30.5	35
											-	1.2 (1.0)	27.4	30
											4.3	1.2 (1.0)	31.7	35
DSG1204L	460/3/60	2	7.7	58.1	2	0.33	0.85	1	5.0	10.6	-	-	29.6	40
											4.3	-	33.9	45
											-	1.2 (1.0)	30.8	40
											4.3	1.2 (1.0)	35.1	45
DSG1204W	460/3/60	2	7.7	58.1	2	0.33	0.85	1	5.0	10.6	-	-	29.6	40
											4.3	-	33.9	45
											-	1.2 (1.0)	30.8	40
											4.3	1.2 (1.0)	35.1	45

Electrical Data

Model Number	Electrical Rating	Compressor			Outdoor Fan Motor			Indoor Fan Motor			Optional Powered Convenience Outlet	Optional Power Exhaust	Power Supply	
		QTY	RLA	LRA	QTY	HP	FLA	Type	HP	FLA	FLA	FLA	MCA	MOP
DSG1207D	575/3/60	2	7.0	47.8	2	0.33	0.67	1	3.5	5.0	-	-	22.2	25
											3.5	-	25.7	30
											-	1.3	23.5	30
											3.5	1.3	27.0	30
DSG1207L	575/3/60	2	7.0	47.8	2	0.33	0.67	1	5.0	7.2	-	-	24.4	30
											3.5	-	27.9	35
											-	1.3	25.7	30
											3.5	1.3	29.2	35
DSG1207W	575/3/60	2	7.0	47.8	2	0.33	0.67	1	5.0	7.2	-	-	24.4	30
											3.5	-	27.9	35
											-	1.3	25.7	30
											3.5	1.3	29.2	35
DSG1503D	208/230/3/60	2	19.2	157	2	0.5	2.7	1	3.5	10.9	-	-	59.5/59.5	70/70
											9.6/8.7	-	69.1/68.2	80/80
											-	3.3/3.0 (2.4)	62.8/62.5	80/80
											9.6/8.7	3.3/3.0 (2.4)	72.4/71.2	90/80
DSG1503L	208/230/3/60	2	19.2	157	2	0.5	2.7	1	5.0	14.5	-	-	63.1/63.1	80/80
											9.6/8.7	-	72.7/71.8	90/90
											-	3.3/3.0 (2.4)	66.4/66.1	80/80
											9.6/8.7	3.3/3.0 (2.4)	76.0/74.8	90/90
DSG1503W	208/230/3/60	2	19.2	157	2	0.5	2.7	1	5.0	14.5	-	-	63.1/63.1	80/80
											9.6/8.7	-	72.7/71.8	90/90
											-	3.3/3.0 (2.4)	66.4/66.1	80/80
											9.6/8.7	3.3/3.0 (2.4)	76.0/74.8	90/90
DSG1504D	460/3/60	2	9.0	74.8	2	0.5	1.4	1	3.5	7.2	-	-	30.2	35
											4.3	-	34.5	40
											-	1.2 (1.0)	31.4	40
											4.3	1.2 (1.0)	35.7	40
DSG1504L	460/3/60	2	9.0	74.8	2	0.5	1.4	1	5.0	10.6	-	-	33.6	40
											4.3	-	37.9	45
											-	1.2 (1.0)	34.8	45
											4.3	1.2 (1.0)	39.1	45
DSG1504W	460/3/60	2	9.0	74.8	2	0.5	1.4	1	5.0	10.6	-	-	33.6	40
											4.3	-	37.9	45
											-	1.2 (1.0)	34.8	45
											4.3	1.2 (1.0)	39.1	45
DSG1507D	575/3/60	2	7.0	53.9	2	0.5	1.0	1	3.5	5.0	-	-	22.8	25
											3.5	-	26.3	30
											-	1.3	24.1	30
											3.5	1.3	27.6	30
DSG1507L	575/3/60	2	7.0	53.9	2	0.5	1.0	1	5.0	7.2	-	-	25.0	30
											3.5	-	28.5	35
											-	1.3	26.3	30
											3.5	1.3	29.8	35
DSG1507W	575/3/60	2	7.0	53.9	2	0.5	1.0	1	5.0	7.2	-	-	25.0	30
											3.5	-	28.5	35
											-	1.3	26.3	30
											3.5	1.3	29.8	35

Electrical Connections

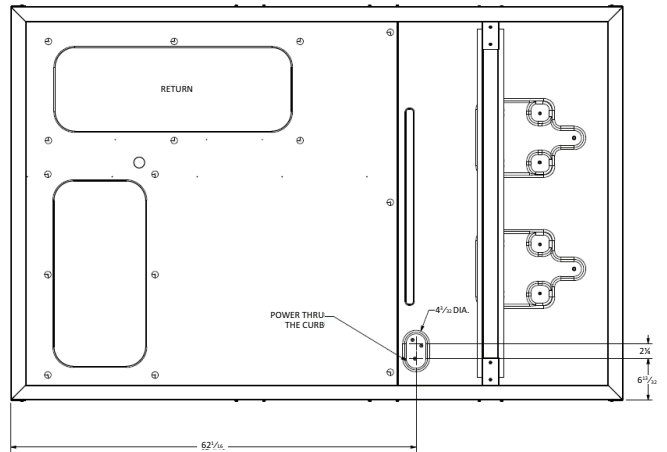
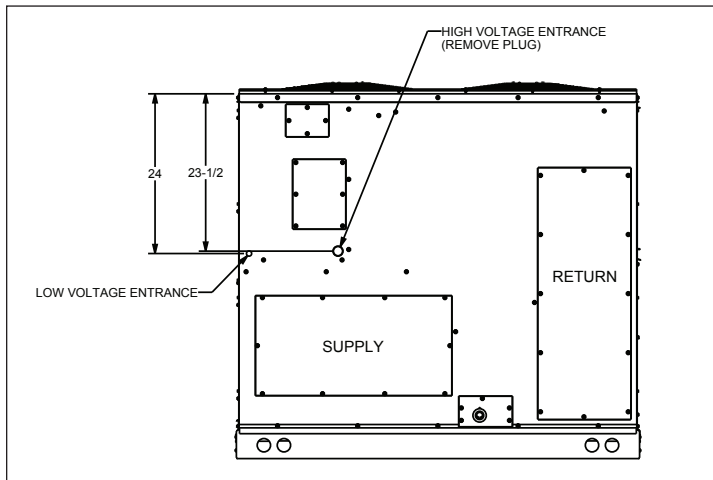
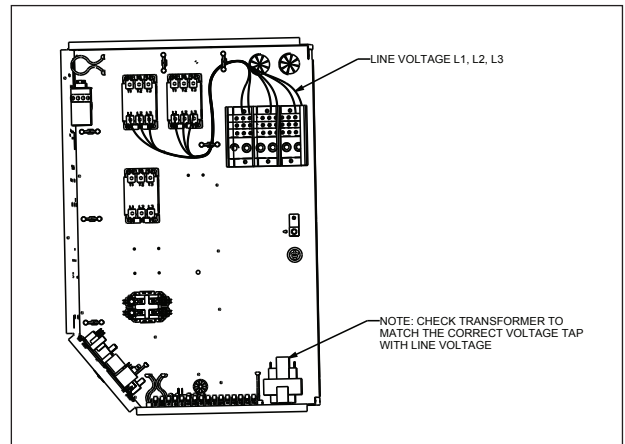
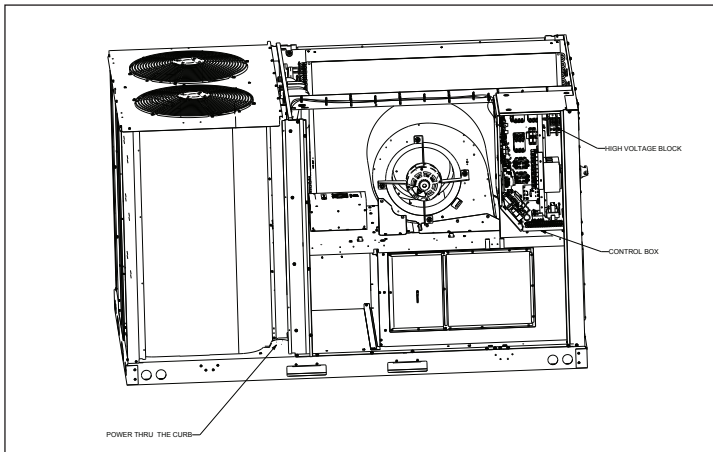

Unit Clearances

Service Clearance

Allow for recommended service clearances as shown in figure to the right. In situations that have multiple units, a 36" minimum clearance is required between the condenser coils. A clearance of 48" is recommended on all sides of the unit to allow service access and to ensure proper ventilation and condenser airflow. The top of the unit should be unobstructed. Provide a roof walkway along the sides of the unit for service and access to controls and components. Contact your Daikin sales representative for service requirements less than those recommended.

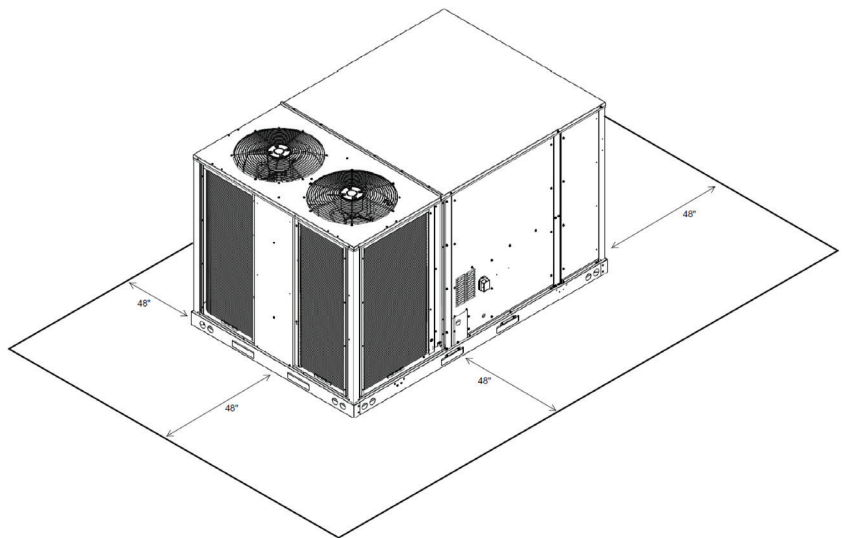

Unit Location

The structural engineer must verify that the roof has adequate support and ability to minimize deflection. Take extreme caution when using on a wooden roof structure. Unit condenser coils should be in a location that avoids any heated exhaust air.

Allow sufficient space around the unit for maintenance/service clearance. Consult your Daikin sales representative if available clearances do not meet minimum recommendations.

Where code considerations, such as the NEC, require extended clearances, these take precedence.

Provisions for forks have been included in the unit base frame. No other fork locations are approved.

- » Unit must be lifted by the four lifting holes located at the base frame corners.
- » Lifting cables should be attached to the unit with shackles.
- » The distance between the crane hook and the top of the unit must not be less than 60".
- » Two spreader bars must span over the unit to prevent damage to the cabinet by the lift cables. Spreader bars must be of sufficient length so that cables do not come in contact with the unit during transport. Remove wood struts mounted beneath unit base

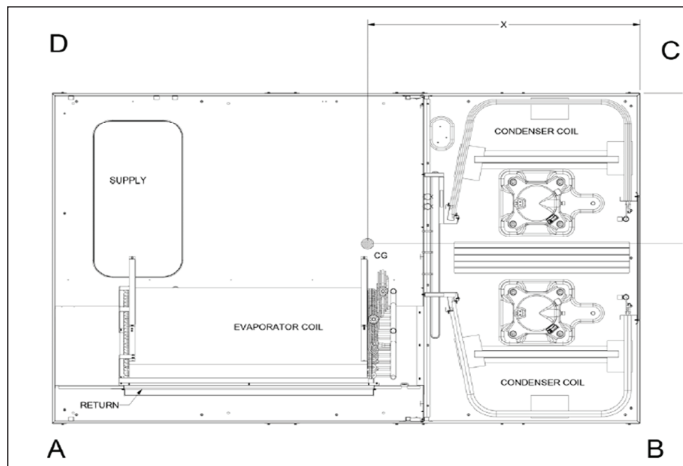

CORNER & CENTER-OF-GRAVITY LOCATIONS

frame before setting unit on roof curb. These struts are intended to protect unit base frame from fork lift damage. To remove the struts, extract the sheet metal retainers and pull the struts through the base of the unit. Refer to rigging label on the unit.

Important: If using bottom discharge with roof curb, ductwork should be attached to the curb prior to installing the unit. Refer to the Roof Curb Installation Instructions for proper curb installation. Curbing must be installed in compliance with the National Roofing Contractors Association Manual. Lower unit carefully onto roof mounting curb. While rigging the unit, the center of gravity will cause the condenser end to be lower than the supply air end. Bring condenser end of unit into alignment with the curb. With condenser end of the unit resting on curb member and using curb as a fulcrum, lower opposite end of the unit until entire unit is seated on the curb. When a rectangular cantilever curb is used, take care to center the unit. Check for proper alignment and orientation of supply and return openings with duct.

Roof Curb Installation

The roof curb is field-assembled and must be installed level (within 1/16" per foot side to side). A sub-base must be constructed by the contractor in applications involving pitched roofs. Gaskets are furnished and must be installed between the unit and curb. For proper installation, follow NRCA guidelines. In applications requiring post and rail installation, an I-beam securely mounted on multiple posts should support the unit on each side. In addition, the insulation on the underside of the unit should be protected from the elements. Applications in geographic areas subjected to seismic or hurricane conditions must meet code requirements for fastening the unit to the curb and the curb to the building structure. For further and more detailed information please refer to our Daikin Light Commercial Packaged unit IOD.

Weights

Model	Shipping Weight (lbs)	Operating Weight (lbs)	Corner Weights (lbs)				Length X (in)	Width Y (in)
			A	B	C	D		
DSG0903D	1106	1178	266	249	297	294	30¾	42
DSG1023D	1118	1190	386	165	225	342	30¾	41 ⁵ / ₁₆
DSG1203D	1161	1233	252	303	258	348	31	43 ¹³ / ₃₂
DSG1503D	1244	1316	254	329	297	364	29 ¹³ / ₁₆	42½

For details on accessories refer to document **PM-LC-ACCESSORIES**

